

1 pC Charge Injection, 100 pA Maximum Leakage, +5 V / +3 V, SPDT Analog Switch

DESCRIPTION

The DG9431E is a monolithic CMOS switch designed for precision signal switching. The 17 Ω low voltage part exhibits low charge injection over the full signal range, low leakage, low parasitic capacitance, and fast switching.

The DG9431E can switch both analog and digital signals. Each switch conducts equally well in both directions when on, and blocks up to the power supply level when off. Break-before-make switching is guaranteed.

The DG9431E offers 1 nW typical power consumption and 8 kV ESD (HBM), 1 kV ESD (CDM) tolerance. It is ideal for use in low voltage instruments and healthcare devices, fitting the circuits of low voltage ADC and DAC, sample and hold, analog front end gain control, and signal path switching. The DG9431E is available in 6-lead TSOP and 8-lead SOIC packages.

APPLICATIONS

- Automatic test equipment
- Process control and automation
- Data acquisition systems
- Meters and instruments
- Medical and healthcare systems
- Communication systems
- Sample-and-hold systems
- Relay replacements
- Battery powered systems

FEATURES

- 1 pC charge injection
- Guaranteed 100 pA max. switch on leakage at 25 $^{\circ}\text{C}$
- 3.8 pF switch off and 7.8 pF switch on capacitances
- +2.7 V to +5 V single supply operation
- Low on-resistance - $R_{\text{DS(on)}}$: 17 Ω (typ.) at 5 V
- t_{ON} : 32 ns, t_{OFF} : 10 ns switching time
- Typical power consumption: 1 nW
- Over voltage tolerance on logic control IN pin
- TTL / CMOS compatible
- ESD (HBM): > 8000 V, ESD (CDM): >1000 V
- Latch-up current: > 300 mA (JESD78)
- Available in TSOP-6 and SOIC-8



Note

* This datasheet provides information about parts that are RoHS-compliant and / or parts that are non RoHS-compliant. For example, parts with lead (Pb) terminations are not RoHS-compliant. Please see the information / tables in this datasheet for details

BENEFITS

- Low charge injection and leakage
- Low parasitic capacitance
- Fast switching speed
- High ESD tolerance

FUNCTIONAL BLOCK DIAGRAM AND PIN CONFIGURATION

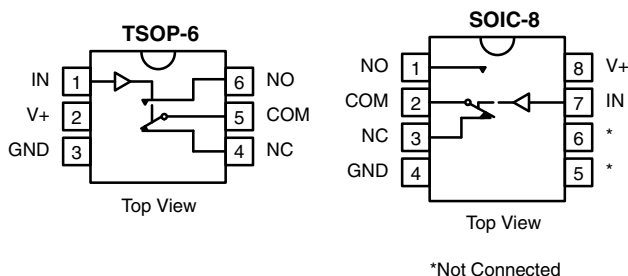

TRUTH TABLE		
LOGIC	NC	NO
0	ON	OFF
1	OFF	ON

Note

- Logic "0" ≤ 0.8 V
- Logic "1" ≥ 2.4 V

ORDERING INFORMATION				
TEMP. RANGE	CONFIGURATION	PART NUMBER	PACKAGE	MINIUM ORDER / PACKAGING QUANTITY
-40 $^{\circ}\text{C}$ to +85 $^{\circ}\text{C}$	DG9431E	6-pin TSOP	DG9431EDV-T1-GE3	Tape and reel 3000 units
		8-pin SOIC	DG9431EDY-T1-GE3	Tape and reel 2500 units
			DG9431EDY-GE3	Tube 500 units



ABSOLUTE MAXIMUM RATINGS			
PARAMETER	LIMIT	UNIT	
Reference V+ to GND	-0.3 to +6	V	
IN, COM, NC, NO ^a	-0.3 to (V+ + 0.3)		
Continuous current (any terminal)	± 20	mA	
Peak current (pulsed at 1 ms, 10 % duty cycle)	± 40		
ESD (HBM) (MIL-STD-883, method 3015)	> 8000	V	
ESD (CDM) (ANSI / ESDA / JEDEC® JS-002)	> 1000		
Latch up current, per JESD78	300	mA	
Storage temperature (D suffix)	-65 to +125	°C	
Power dissipation (packages) ^b	8-pin narrow body SOIC ^c	400	mW
	6-pin TSOP ^d	570	

Notes

- a. Signals on SX, DX, or INX exceeding V+ or V- will be clamped by internal diodes. Limit forward diode current to maximum current ratings.
- b. All leads welded or soldered to PC board.
- c. Derate 6.5 mW/°C above 75 °C.
- d. Derate 7 mW/°C above 70 °C.

SPECIFICATIONS (V+ = 3 V)							
PARAMETER	SYMBOL	TEST CONDITIONS UNLESS OTHERWISE SPECIFIED V+ = 3 V, ± 10 %, V _{IN} = 0.8 V or 2.4 V ^e	TEMP. ^a	D SUFFIX -40 °C TO +85 °C			UNIT
				MIN. ^c	TYP. ^b	MAX. ^c	
Analog Switch							
Analog signal range ^d	V _{ANALOG}		Full	0	-	3	V
Drain-source on-resistance	R _{DS(on)}	V _{NO} or V _{NC} = 1.5 V, V+ = 2.7 V I _{COM} = 5 mA	Room	-	35	50	Ω
			Full	-	-	65	
R _{DS(on)} match ^d	ΔR _{DS(on)}	V _{NO} or V _{NC} = 1.5 V	Room	-	0.4	2	
R _{DS(on)} flatness ^f	R _{DS(on)} flatness	V _{NO} or V _{NC} = 1 V and 2 V	Room	-	4	8	
NO or NC off leakage current ^g	I _{NO/NC(off)}	V _{NO} or V _{NC} = 1 V / 2 V, V _{COM} = 2 V / 1 V	Room	-100	5	100	pA
			Full	-5000	-	5000	
COM off leakage current ^g	I _{COM(off)}	V _{COM} = 1 V / 2 V, V _{NO} or V _{NC} = 2 V / 1 V	Room	-100	5	100	pA
			Full	-5000	-	5000	
Channel-on leakage current ^g	I _{COM(on)}	V _{COM} = V _{NO} or V _{NC} = 1 V / 2 V	Room	-200	5	200	pA
			Full	-10 000	-	10 000	
Digital Control							
Input current	I _{INL} or I _{INH}		Full	-	0.001	-	μA
Dynamic Characteristics							
Turn-on time	t _{ON}	V _{NO} or V _{NC} = 1.5 V	Room	-	43	120	ns
			Full	-	-	200	
Turn-Off Time	t _{OFF}	V _{NO} or V _{NC} = 1.5 V	Room	-	16	50	ns
			Full	-	-	120	
Break-before-make time	t _d		Room	3	26	-	
Charge injection	Q _{INJ}	C _L = 1 nF, V _{gen} = 0 V, R _{gen} = 0 Ω	Room	-	-0.28	-	pC
Off-isolation	O _{IRR}	R _L = 50 Ω, C _L = 5 pF, f = 1 MHz	Room	-	-80	-	dB
Crosstalk	X _{TALK}		Room	-	-108	-	
Source off capacitance	C _{S(off)}	f = 1 MHz	Room	-	4	-	pF
Channel-on capacitance	C _{D(on)}		Room	-	8	-	
Power Supply							
Power supply range	V+			2.7	-	5.5	V
Power supply current	I+	V+ = 3.3 V, V _{IN} = 0 V or 3.3 V		-	0.0003	1	μA



SPECIFICATIONS (V+ = 5 V)								
PARAMETER	SYMBOL	TEST CONDITIONS UNLESS OTHERWISE SPECIFIED V+ = 5 V, ± 10 %, VIN = 0.8 V or 2.4 V ^e	TEMP. ^a	D SUFFIX -40 °C to +85 °C			UNIT	
				MIN. ^c	TYP. ^b	MAX. ^c		
Analog Switch								
Analog signal range ^d	V _{ANALOG}		Full	0	-	5	V	
Drain-source on-resistance	R _{DS(on)}	V _{NO} or V _{NC} = 3.5 V, V+ = 4.5 V I _{COM} = 5 mA	Room	-	17	25	Ω	
			Full	-	-	35		
R _{DS(on)} match ^d	ΔR _{DS(on)}	V _{NO} or V _{NC} = 1.5 V	Room	-	0.4	2		
R _{DS(on)} flatness ^f	R _{DS(on)} flatness	V _{NO} or V _{NC} = 1 V, 2 V, and 3 V	Room	-	3.5	6		
NO or NC off leakage current	I _{NO/NC(off)}	V _{NO} or V _{NC} = 1 V / 4 V, V _{COM} = 4 V / 1 V	Room	-100	10	100	pA	
			Full	-5000	-	5000		
COM off leakage current	I _{COM(off)}	V _{COM} = 1 V / 4 V, V _{NO} or V _{NC} = 4 V / 1 V	Room	-100	10	100		
			Full	-5000	-	5000		
Channel-on leakage current	I _{COM(on)}	V _{COM} = V _{NO} or V _{NC} = 1 V / 4 V	Room	-200	-	200		
			Full	-10 000	-	10 000		
Digital Control								
Input current	I _{INL} or I _{INH}		Full	-	0.001	-	μA	
Dynamic Characteristics								
Turn-on time	t _{ON}	V _{NO} or V _{NC} = 3 V	Room	-	32	75	ns	
			Full	-	-	150		
Turn-off time	t _{OFF}		Room	-	10	50		
			Full	-	-	100		
Break-before-make time	t _d			Room	3	22	-	
Charge injection	Q _{INJ}		C _L = 1 nF, V _{gen} = 0 V, R _{gen} = 0 Ω	Room	-	-0.78	-	pC
Off-isolation	O _{IRR}		R _L = 50 Ω, C _L = 5 pF, f = 1 MHz	Room	-	-80	-	dB
Crosstalk	X _{TALK}			Room	-	-108	-	
NC and NO capacitance	C _(off)	f = 1 MHz	Room	-	3.8	-	pF	
Channel-on capacitance	C _{D(on)}		Room	-	7.8	-		
Power Supply								
Power supply range	V+			2.7	-	5.5	V	
Power supply current	I+	V+ = 5.5 V, V _{IN} = 0 V or 5.5 V		-	0.0004	1	μA	

Notes

- a. Room = 25 °C, Full = as determined by the operating suffix.
- b. Typical values are for design aid only, not guaranteed nor subject to production testing.
- c. The algebraic convention whereby the most negative value is a minimum and the most positive a maximum, is used in this datasheet.
- d. Guarantee by design, nor subjected to production test.
- e. V_{IN} = input voltage to perform proper function.
- f. Difference of min and max values.
- g. Guaranteed by 5 V leakage testing, not production tested.

Stresses beyond those listed under "Absolute Maximum Ratings" may cause permanent damage to the device. These are stress ratings only, and functional operation of the device at these or any other conditions beyond those indicated in the operational sections of the specifications is not implied. Exposure to absolute maximum rating conditions for extended periods may affect device reliability.

TYPICAL CHARACTERISTICS ($T_A = 25\text{ }^\circ\text{C}$, unless otherwise noted)

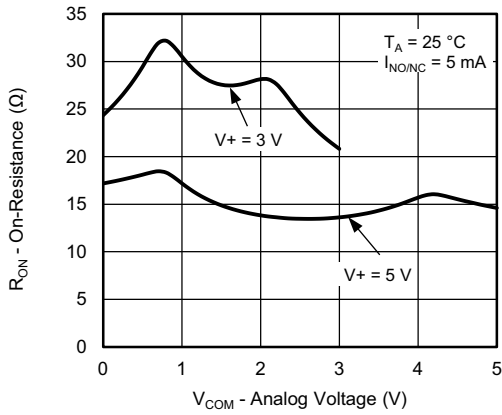

On-Resistance vs. Analog Voltage

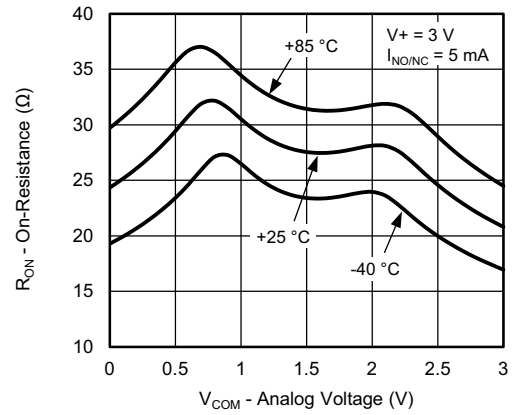

On-Resistance vs. Analog Voltage

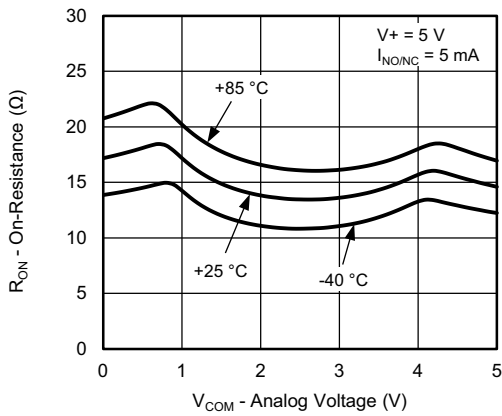

On-Resistance vs. Analog Voltage

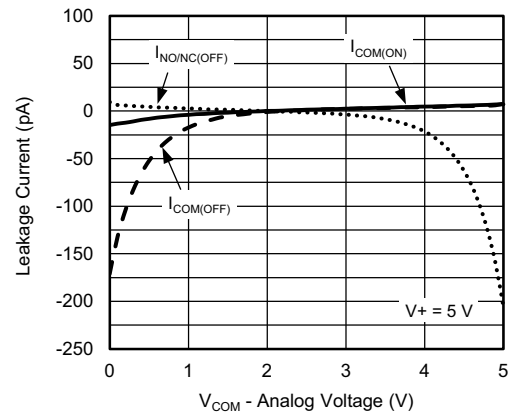

Leakage Current vs. Analog Voltage

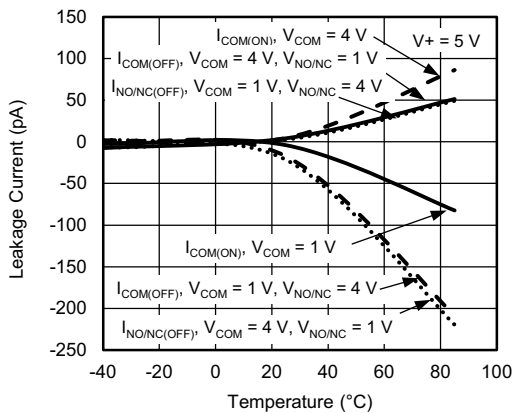

Leakage Current vs. Temperature

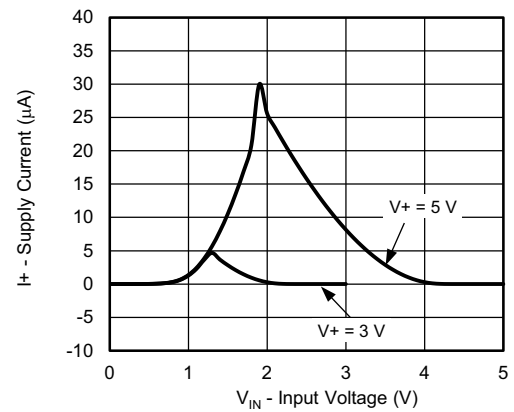

Supply Current vs. Input Voltage

TYPICAL CHARACTERISTICS ($T_A = 25\text{ }^\circ\text{C}$, unless otherwise noted)

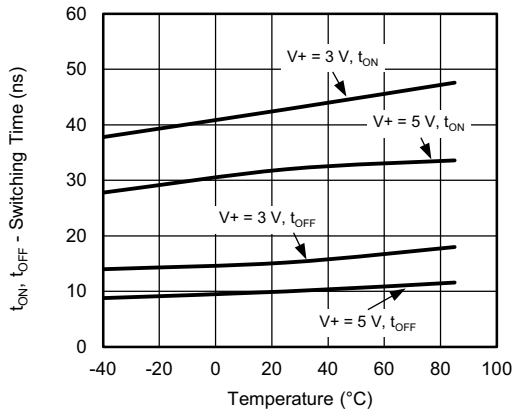

Switching Time vs. Temperature

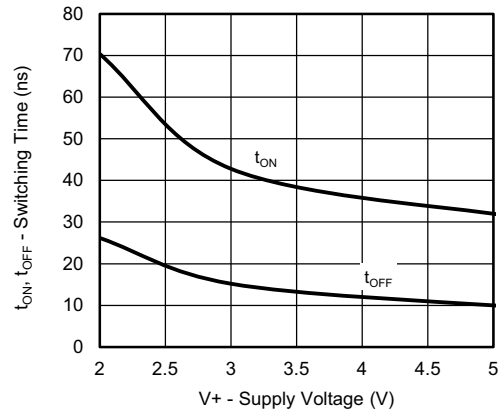

Switching Time vs. Supply Voltage

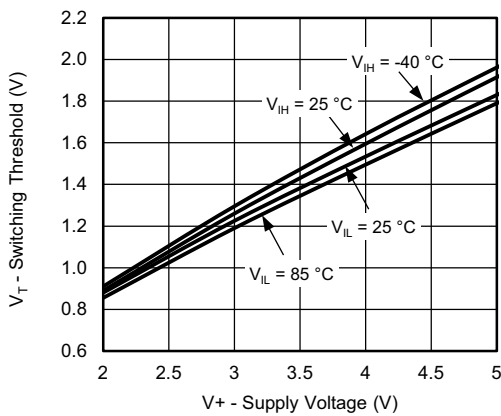

Switching Threshold vs. Supply Voltage

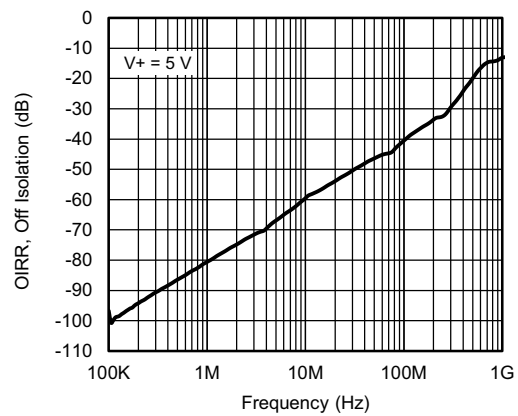

OIRR, Off Isolation vs. Frequency

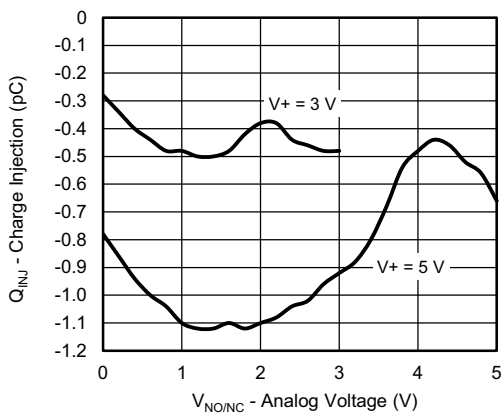

Charge Injection vs. Analog Voltage

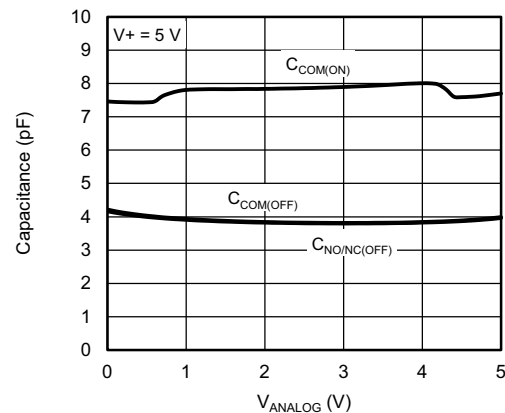

Capacitance

TEST CIRCUITS

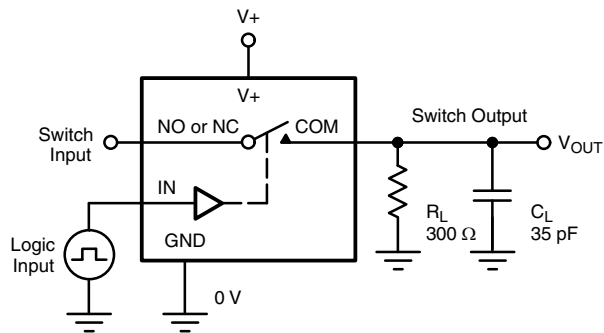

C_L (includes fixture and stray capacitance)

$$V_{OUT} = V_{COM} \left(\frac{R_L}{R_L + R_{ON}} \right)$$

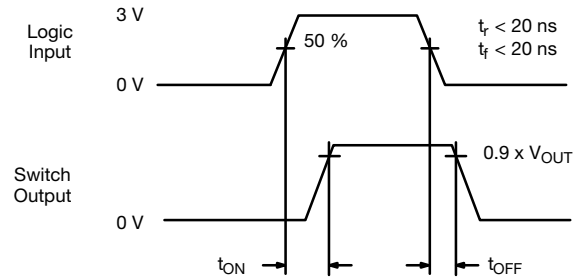

Logic "1" = switch on
Logic input waveforms inverted for switches that have the opposite logic sense.

Figure 1. Switching Time

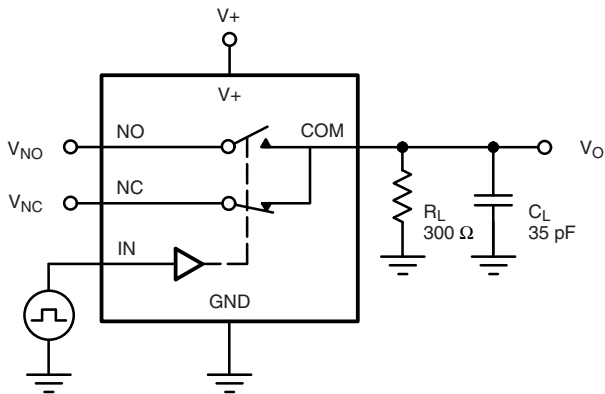

C_L (includes fixture and stray capacitance)

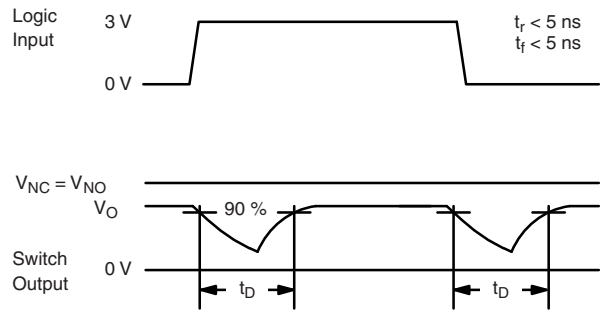
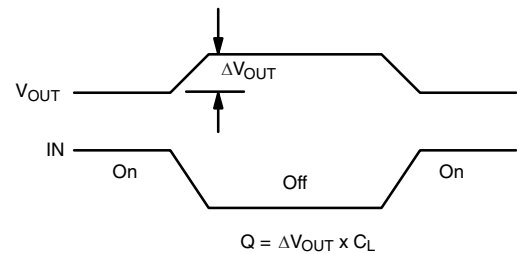
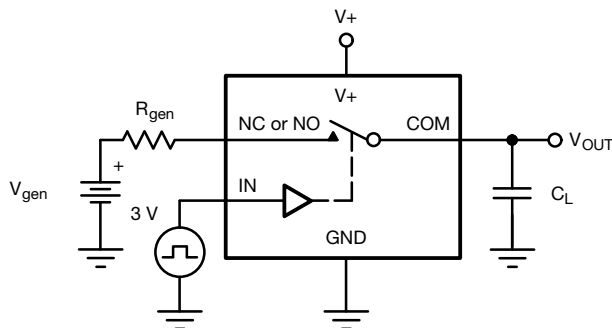

Figure 2. Break-Before-Make Interval



IN depends on switch configuration: input polarity determined by sense of switch.

Figure 3. Charge Injection

TEST CIRCUITS

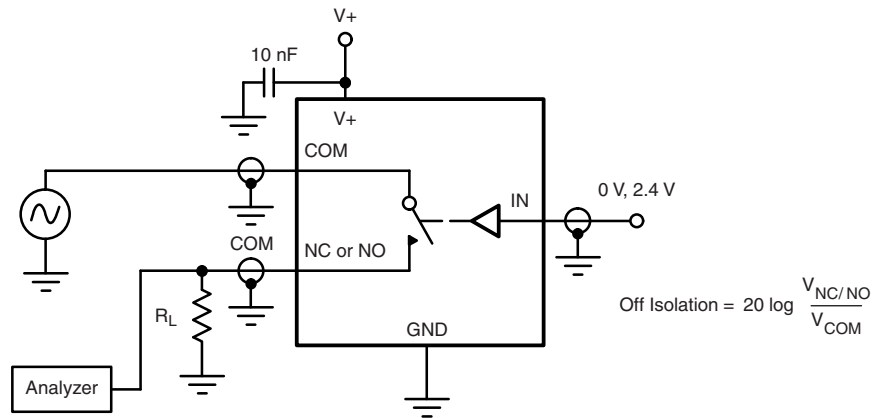

Figure 4. Off-Isolation

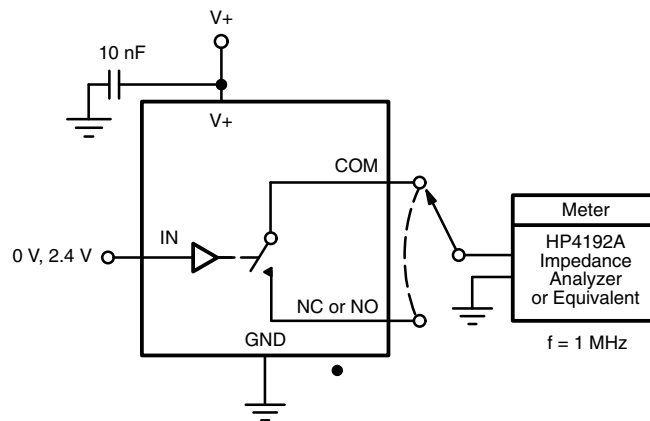

Figure 5. Channel Off/On Capacitance



PRODUCT SUMMARY		
Part number	DG9431E	DG9431E
Status code	2	2
Configuration	SPDT x 1	SPDT x 1
Single supply min. (V)	2.7	2.7
Single supply max. (V)	5.5	5.5
Dual supply min. (V)	-	-
Dual supply max. (V)	-	-
On-resistance (Ω)	17 at 5 V	17 at 5 V
Charge injection (pC)	78 at 5 V	78 at 5 V
Source on capacitance (pF)	8	8
Source off capacitance (pF)	4	4
Leakage switch on typ. (nA)	0.005	0.005
Leakage switch off max. (nA)	0.1	0.1
-3 dB bandwidth (MHz)	-	-
Package	TSOP-6	SO-8 (narrow) AS
Functional circuit / applications	Multi purpose, instrumentation, medical and healthcare, portable	Multi purpose, instrumentation, medical and healthcare, portable
Interface	Binary	Binary
Single supply operation	Yes	Yes
Dual supply operation	-	-
Turn on time max. (ns)	75	75
Crosstalk and off isolation	108	108

Vishay Siliconix maintains worldwide manufacturing capability. Products may be manufactured at one of several qualified locations. Reliability data for Silicon Technology and Package Reliability represent a composite of all qualified locations. For related documents such as package/tape drawings, part marking, and reliability data, see www.vishay.com/ppg?76459.

SOIC (NARROW): 8-LEAD

JEDEC Part Number: MS-012

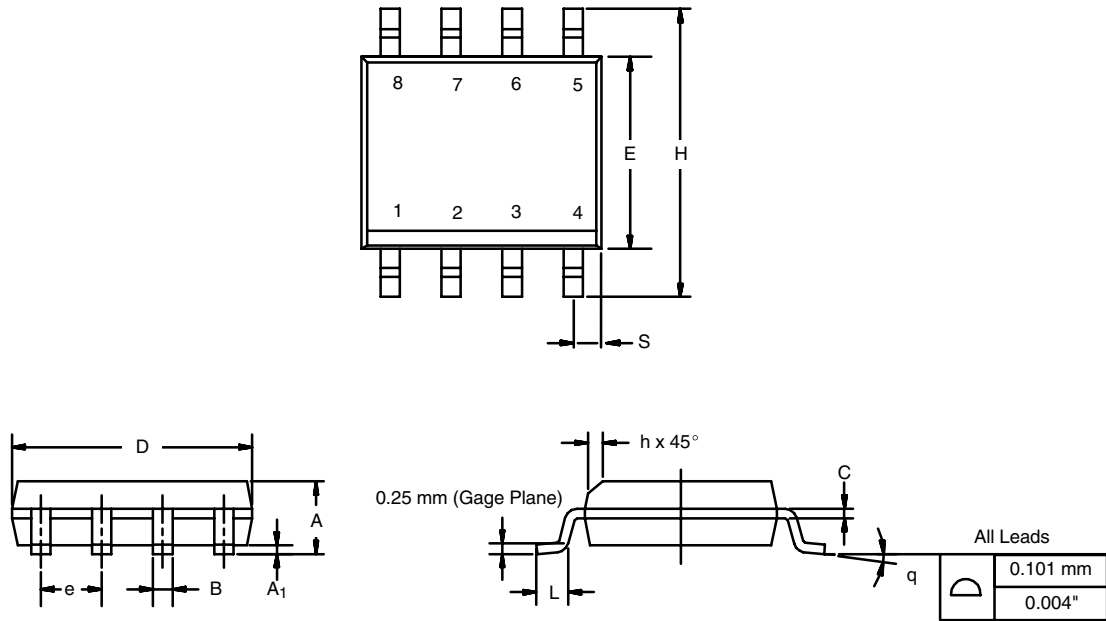

DIM	MILLIMETERS		INCHES	
	Min	Max	Min	Max
A	1.35	1.75	0.053	0.069
A ₁	0.10	0.20	0.004	0.008
B	0.35	0.51	0.014	0.020
C	0.19	0.25	0.0075	0.010
D	4.80	5.00	0.189	0.196
E	3.80	4.00	0.150	0.157
e	1.27 BSC		0.050 BSC	
H	5.80	6.20	0.228	0.244
h	0.25	0.50	0.010	0.020
L	0.50	0.93	0.020	0.037
q	0°	8°	0°	8°
S	0.44	0.64	0.018	0.026
ECN: C-06527-Rev. I, 11-Sep-06				
DWG: 5498				

TSOP: 5/6-LEAD

JEDEC Part Number: MO-193C

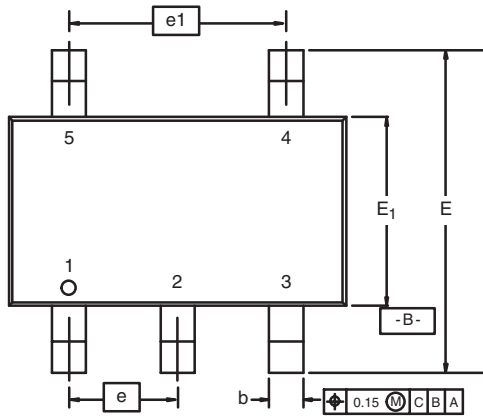

5-LEAD TSOP

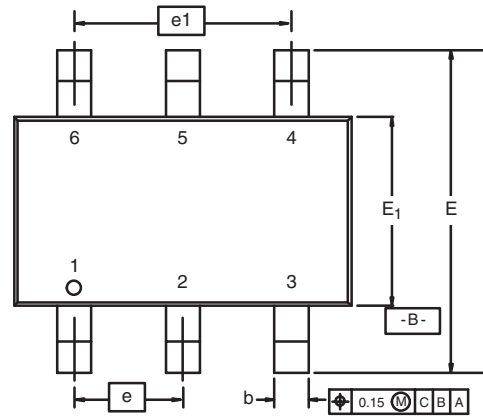

6-LEAD TSOP

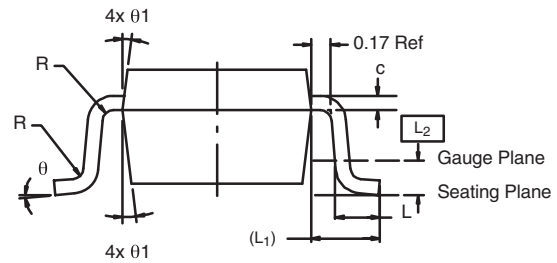
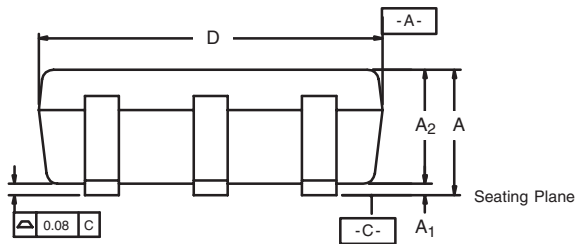

Dim	MILLIMETERS			INCHES		
	Min	Nom	Max	Min	Nom	Max
A	0.91	-	1.10	0.036	-	0.043
A₁	0.01	-	0.10	0.0004	-	0.004
A₂	0.90	-	1.00	0.035	0.038	0.039
b	0.30	0.32	0.45	0.012	0.013	0.018
c	0.10	0.15	0.20	0.004	0.006	0.008
D	2.95	3.05	3.10	0.116	0.120	0.122
E	2.70	2.85	2.98	0.106	0.112	0.117
E₁	1.55	1.65	1.70	0.061	0.065	0.067
e	0.95 BSC			0.0374 BSC		
e₁	1.80	1.90	2.00	0.071	0.075	0.079
L	0.32	-	0.50	0.012	-	0.020
L₁	0.60 Ref			0.024 Ref		
L₂	0.25 BSC			0.010 BSC		
R	0.10	-	-	0.004	-	-
θ	0°	4°	8°	0°	4°	8°
θ₁	7° Nom			7° Nom		
ECN: C-06593-Rev. I, 18-Dec-06						
DWG: 5540						

RECOMMENDED MINIMUM PADS FOR SO-8



Recommended Minimum Pads
Dimensions in Inches/(mm)

[Return to Index](#)



Recommended Land Pattern For TSOP-5L / TSOP-6L

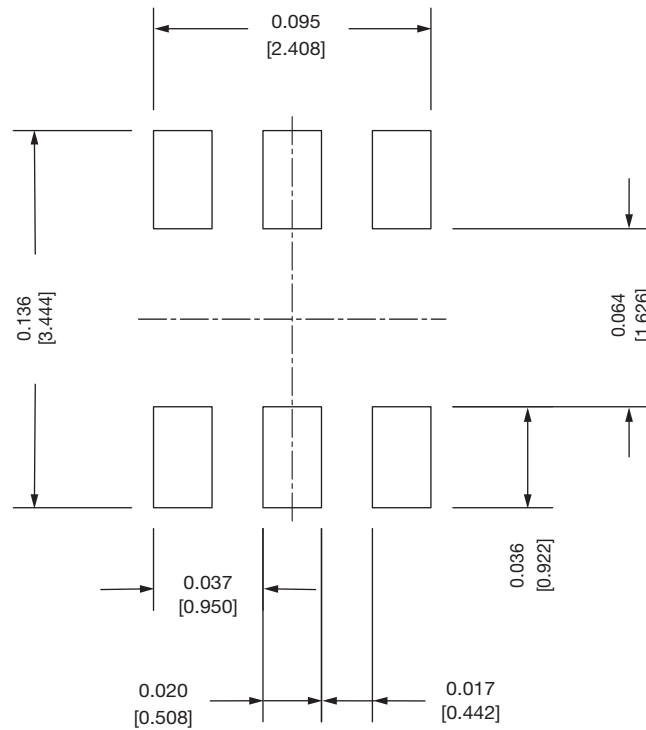
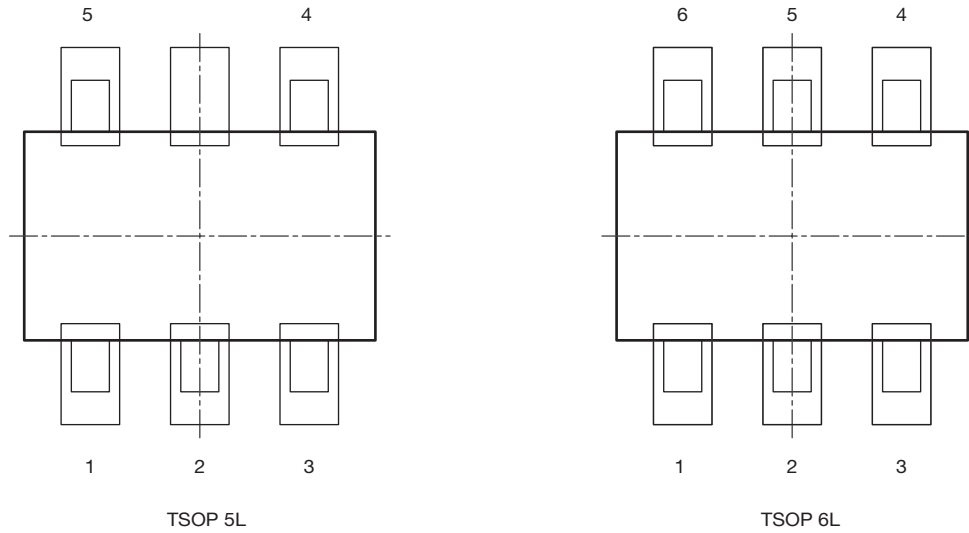

Note

- All dimensions are in inches (millimeter)

ECN: C22-0860-Rev. B, 24-Oct-2022
 DWG: 3010



Disclaimer

ALL PRODUCT, PRODUCT SPECIFICATIONS AND DATA ARE SUBJECT TO CHANGE WITHOUT NOTICE TO IMPROVE RELIABILITY, FUNCTION OR DESIGN OR OTHERWISE.

Vishay Intertechnology, Inc., its affiliates, agents, and employees, and all persons acting on its or their behalf (collectively, "Vishay"), disclaim any and all liability for any errors, inaccuracies or incompleteness contained in any datasheet or in any other disclosure relating to any product.

Vishay makes no warranty, representation or guarantee regarding the suitability of the products for any particular purpose or the continuing production of any product. To the maximum extent permitted by applicable law, Vishay disclaims (i) any and all liability arising out of the application or use of any product, (ii) any and all liability, including without limitation special, consequential or incidental damages, and (iii) any and all implied warranties, including warranties of fitness for particular purpose, non-infringement and merchantability.

Statements regarding the suitability of products for certain types of applications are based on Vishay's knowledge of typical requirements that are often placed on Vishay products in generic applications. Such statements are not binding statements about the suitability of products for a particular application. It is the customer's responsibility to validate that a particular product with the properties described in the product specification is suitable for use in a particular application. Parameters provided in datasheets and / or specifications may vary in different applications and performance may vary over time. All operating parameters, including typical parameters, must be validated for each customer application by the customer's technical experts. Product specifications do not expand or otherwise modify Vishay's terms and conditions of purchase, including but not limited to the warranty expressed therein.

Hyperlinks included in this datasheet may direct users to third-party websites. These links are provided as a convenience and for informational purposes only. Inclusion of these hyperlinks does not constitute an endorsement or an approval by Vishay of any of the products, services or opinions of the corporation, organization or individual associated with the third-party website. Vishay disclaims any and all liability and bears no responsibility for the accuracy, legality or content of the third-party website or for that of subsequent links.

Vishay products are not designed for use in life-saving or life-sustaining applications or any application in which the failure of the Vishay product could result in personal injury or death unless specifically qualified in writing by Vishay. Customers using or selling Vishay products not expressly indicated for use in such applications do so at their own risk. Please contact authorized Vishay personnel to obtain written terms and conditions regarding products designed for such applications.

No license, express or implied, by estoppel or otherwise, to any intellectual property rights is granted by this document or by any conduct of Vishay. Product names and markings noted herein may be trademarks of their respective owners.