



## 6 Ω On-Resistance, +12 V, ± 5 V, +5 V, +3 V, SPST and SPDT Switches

### DESCRIPTION

DG417LE, DG418LE, DG419LE analog switches are designed to operate from +3 V to +16 V single supply or ± 3 V to ± 8 V dual supply and are fully specified at +12 V, ± 5 V, +5 V, and +3 V.

The DG417LE, DG418LE, DG419LE are lower voltage pin-for-pin compatible companion devices to the industry standard DG417, DG418, and DG419. Each switch conducts equally well in both directions when on, blocks input voltages up to the supply level when off, and exhibits break before switching action.

Fabricated with advanced CMOS technology, the parts provide low on resistance and fast switching speed with low power dissipation.

The DG417LE, DG418LE, DG419LE operating temperature range is -40 °C to +85 °C and devices are available in 8 lead TSSOP and SOIC packages.

### FEATURES

- +3 V to +16 V single supply, or ± 3 V to ± 8 V dual supply
- On resistance: 6 Ω for DG417LE, DG418LE  
11 Ω for DG419LE
- Fast switching speeds:  $t_{ON} = 20 \text{ ns}$ ,  $t_{OFF} = 15 \text{ ns}$
- Break-before-make switching for DG419LE
- Fully specified at +12 V, ± 5 V, +5 V, and +3 V
- V+ to V- analog signal range
- CMOS / TTL compatible
- Control logic input can be over V+
- 8 pin TSSOP and 8 pin SOIC packages
- Material categorization: for definitions of compliance please see [www.vishay.com/doc?99912](http://www.vishay.com/doc?99912)



### Note

\* This datasheet provides information about parts that are RoHS-compliant and / or parts that are non RoHS-compliant. For example, parts with lead (Pb) terminations are not RoHS-compliant. Please see the information / tables in this datasheet for details

### APPLICATIONS

- Data acquisition systems
- Medical instruments
- Precision instruments
- Communications systems
- Automated test equipment
- Sample and hold circuit
- Audio and video signal routing

### FUNCTIONAL BLOCK DIAGRAM AND PIN CONFIGURATION

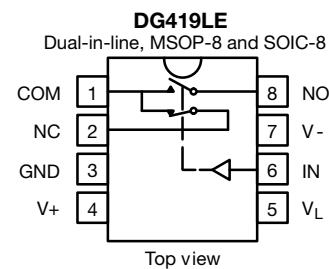
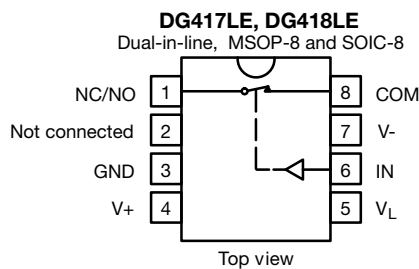

TRUTH TABLE (DG417LE, DG418LE)		
LOGIC	DG417LE	DG418LE
0	On	Off
1	Off	On

TRUTH TABLE (DG419LE)		
LOGIC	NC	NO
0	On	Off
1	Off	On

ORDERING INFORMATION (DG417LE, DG418LE)		
TEMP. RANGE	PACKAGE	PART NUMBER
-40 °C to +85 °C	8-pin narrow SOIC	DG417LEDY-T1-GE4
		DG418LEDY-T1-GE4
	8-pin MSOP	DG417LEDQ-T1-GE3
		DG418LEDQ-T1-GE3

ORDERING INFORMATION (DG419LE)		
TEMP. RANGE	PACKAGE	PART NUMBER
-40 °C to +85 °C	8-pin narrow SOIC	DG419LEDY-T1-GE4
	8-pin MSOP	DG419LEDQ-T1-GE3



ABSOLUTE MAXIMUM RATINGS			
PARAMETER		LIMIT	UNIT
V+, V <sub>L</sub> , IN reference to V-		-0.3 to 18	V
V+ reference to GND		-0.3 to 18	
GND reference to V-		-0.3 to 18	
COM, NC, NO reference to V- <sup>a</sup>		-0.3 to (V+ + 0.3) or 30 mA, whichever occurs first	
Continuous current (any terminal)		30	mA
Peak current, S or D (pulsed 1 ms, 10 % duty cycle)		100	
Storage temperature	(DQ, DY suffix)	-65 to +150	°C
Power dissipation (packages) <sup>b</sup>	8-pin MSOP <sup>c</sup>	320	mW
	8-pin SOIC <sup>c</sup>	400	
ESD / HBM	JS-001	2000	V
ESD / CDM	JS-002	2000	
Latch up	JESD78	300	mA

**Notes**

- a. Signals on NC, NO, or COM exceeding V+ or V- will be clamped by internal diodes. Limit forward diode current to maximum current ratings
- b. All leads welded or soldered to PC board
- c. Derate 6.5 mW/°C above 25 °C

*Stresses beyond those listed under "Absolute Maximum Ratings" may cause permanent damage to the device. These are stress ratings only, and functional operation of the device at these or any other conditions beyond those indicated in the operational sections of the specifications is not implied. Exposure to absolute maximum rating conditions for extended periods may affect device reliability.*



SPECIFICATIONS (Single supply 12 V)							
PARAMETER	SYMBOL	TEST CONDITIONS UNLESS OTHERWISE SPECIFIED V <sub>+</sub> = 12 V, V <sub>-</sub> = 0 V V <sub>L</sub> = 5 V, V <sub>IN</sub> = 2.4 V, 0.8 V <sup>f</sup>	TEMP. <sup>b</sup>	TYP. <sup>c</sup>	D SUFFIX LIMITS -40 °C to +85 °C		UNIT
					MIN. <sup>d</sup>	MAX. <sup>d</sup>	
<b>Analog Switch</b>							
Analog signal range <sup>e</sup>	V <sub>ANALOG</sub>		Full	-	0	12	V
Drain-source on-resistance	R <sub>DS(on)</sub>	V <sub>+</sub> = 10.8 V, V <sub>-</sub> = 0 V I <sub>NO</sub> , I <sub>NC</sub> = 5 mA, V <sub>COM</sub> = 2 V / 9 V, DG417LE, DG418LE only	Room	6	-	7	Ω
			Full	-	-	9	
		V <sub>+</sub> = 10.8 V, V <sub>-</sub> = 0 V I <sub>NO</sub> , I <sub>NC</sub> = 5 mA, V <sub>COM</sub> = 2 V / 9 V, DG419LE only	Room	11	-	14	
			Full	-	-	18	
Switch off leakage current	I <sub>NO(off)</sub> I <sub>NC(off)</sub>	V <sub>COM</sub> = 1 V / 11 V V <sub>NO</sub> , V <sub>NC</sub> = 11 V / 1 V	Room	± 0.002	-2	2	nA
			Full	-	-10	10	
	I <sub>COM(off)</sub>		Room	± 0.003	-2	2	
			Full	-	-10	10	
Switch on leakage current	I <sub>COM(on)</sub>	V <sub>NO</sub> , V <sub>NC</sub> = V <sub>COM</sub> = 11 V / 1 V	Room	± 0.006	-2	2	
			Full	-	-10	10	
<b>Digital Control</b>							
Input current	I <sub>INL</sub> or I <sub>INH</sub>		Full	0.02	-1	1	μA
<b>Dynamic Characteristics</b>							
Turn-on time	t <sub>ON</sub>	R <sub>L</sub> = 300 Ω, C <sub>L</sub> = 35 pF V <sub>NO</sub> , V <sub>NC</sub> = 5 V	Room	20	-	38	ns
			Full	-	-	40	
Turn-off time	t <sub>OFF</sub>		Room	15	-	32	
			Full	-	-	35	
Break-before-make time	t <sub>BBM</sub>	DG419LE only, V <sub>NC</sub> , V <sub>NO</sub> = 5 V R <sub>L</sub> = 300 Ω, C <sub>L</sub> = 35 pF	Room	7	-	-	
Charge injection <sup>e</sup>	Q <sub>INJ</sub>	V <sub>GEN</sub> = 0 V, R <sub>GEN</sub> = 0 Ω, C <sub>L</sub> = 1 nF	Room	26	-	-	pC
Off-isolation <sup>e</sup>	OIRR	R <sub>L</sub> = 50 Ω, C <sub>L</sub> = 5 pF, f = 1 MHz	Room	-68	-	-	dB
Channel-to-channel crosstalk <sup>e</sup>	X <sub>TALK</sub>		Room	-72	-	-	
Source off capacitance <sup>e</sup>	C <sub>NO(off)</sub> C <sub>NC(off)</sub>	V <sub>IN</sub> = 0 V or V <sub>+</sub> , f = 1 MHz, DG417LE, DG418LE only	Room	11	-	-	pF
Drain-on capacitance <sup>e</sup>	C <sub>ON</sub>		Room	32	-	-	
Source off capacitance <sup>e</sup>	C <sub>NO(off)</sub> C <sub>NC(off)</sub>	V <sub>IN</sub> = 0 V or V <sub>+</sub> , f = 1 MHz, DG419LE only	Room	6	-	-	
Drain-on capacitance <sup>e</sup>	C <sub>ON</sub>		Room	20	-	-	
<b>Power Supplies</b>							
Positive supply current	I <sub>+</sub>	V <sub>IN</sub> = 0 V or V <sub>L</sub>	Room	0.00009	-	1	μA
			Full	-	-	5	
Negative supply current	I <sub>-</sub>		Room	-0.00009	-1	-	
			Full	-	-5	-	
Logic supply current	I <sub>L</sub>		Room	0.00002	-	1	
			Full	-	-	5	
Ground current	I <sub>GND</sub>		Room	-0.00002	-1	-	
			Full	-	-5	-	



SPECIFICATIONS (Dual supply $\pm 5$ V)							
PARAMETER	SYMBOL	TEST CONDITIONS UNLESS OTHERWISE SPECIFIED $V_+ = 5$ V, $V_- = -5$ V $V_L = 5$ V, $V_{IN} = 2.4$ V, $0.8$ V <sup>f</sup>	TEMP. <sup>b</sup>	TYP. <sup>c</sup>	D SUFFIX LIMITS -40 °C to +85 °C		UNIT
					MIN. <sup>d</sup>	MAX. <sup>d</sup>	
<b>Analog Switch</b>							
Analog signal range <sup>e</sup>	$V_{ANALOG}$		Full	-	-5	5	V
Drain-source on-resistance	$R_{DS(on)}$	$V_+ = 5$ V, $V_- = -5$ V $I_{NO}, I_{NC} = 5$ mA, $V_{COM} = \pm 3.5$ V DG417LE / DG418LE only	Room	6	-	8	$\Omega$
			Full	-	-	10	
		$V_+ = 5$ V, $V_- = -5$ V $I_{NO}, I_{NC} = 5$ mA, $V_{COM} = \pm 3.5$ V DG419LE only	Room	12	-	15	
			Full	-	-	21	
Switch off leakage current <sup>a</sup>	$I_{NO(off)}$ $I_{NC(off)}$	$V_+ = 5.5$ V, $V_- = -5.5$ V $V_{COM} = \pm 4.5$ V $V_{NO}, V_{NC} = \pm 4.5$ V	Room	$\pm 0.001$	-2	2	nA
			Full	-	-10	10	
	$I_{COM(off)}$		Room	$\pm 0.002$	-2	2	
			Full	-	-10	10	
Channel on leakage current <sup>a</sup>	$I_{COM(on)}$	$V_+ = 5.5$ V, $V_- = -5.5$ V $V_{NO}, V_{NC} = V_{COM} = \pm 4.5$ V	Room	$\pm 0.003$	-2	2	
			Full	-	-10	10	
<b>Digital Control</b>							
Input current <sup>a</sup>	$I_{INL}$ or $I_{INH}$		Full	0.02	-1	1	$\mu$ A
<b>Dynamic Characteristics</b>							
Turn-on time <sup>e</sup>	$t_{ON}$	$R_L = 300$ $\Omega$ , $C_L = 35$ pF $V_{NO}, V_{NC} = \pm 3.5$ V	Room	21	-	38	ns
			Full	-	-	40	
Turn-off time <sup>e</sup>	$t_{OFF}$		Room	20	-	45	
			Full	-	-	50	
Break-before-make time <sup>e</sup>	$t_{BBM}$	DG419LE only, $V_{NO}, V_{NC} = 3.5$ V $R_L = 300$ $\Omega$ , $C_L = 35$ pF	Room	7	-	-	
Transition time	$t_{TRANS}$	$R_L = 300$ $\Omega$ , $C_L = 35$ pF $V_{S1} = \pm 3.5$ V, $V_{S2} = \pm 3.5$ V	Room	21	-	-	
Charge injection <sup>e</sup>	$Q_{INJ}$	$V_{GEN} = 0$ V, $R_{GEN} = 0$ $\Omega$ , $C_L = 1$ nF	Room	-17	-	-	pC
Off-isolation <sup>e</sup>	OIRR	$R_L = 50$ $\Omega$ , $C_L = 5$ pF, $f = 1$ MHz	Room	-69	-	-	dB
Channel-to-channel crosstalk <sup>e</sup>	$X_{TALK}$		Room	-73	-	-	
Source off capacitance <sup>e</sup>	$C_{NO(off)}$ $C_{NC(off)}$	$V_{IN} = 0$ V or $V_+$ , $f = 1$ MHz DG417LE / DG418LE only	Room	11	-	-	pF
Drain-on capacitance <sup>e</sup>	$C_{ON}$		Room	33	-	-	
Source off capacitance <sup>e</sup>	$C_{NO(off)}$ $C_{NC(off)}$	$V_{IN} = 0$ V or $V_+$ , $f = 1$ MHz DG419LE only	Room	6	-	-	
Drain-on capacitance <sup>e</sup>	$C_{ON}$		Room	20	-	-	
<b>Power Supplies</b>							
Positive supply current <sup>e</sup>	$I_+$	$V_{IN} = 0$ V or $V_L$	Room	0.00007	-	1	$\mu$ A
			Full	-	-	5	
Negative supply current <sup>e</sup>	$I_-$		Room	-0.00009	-1	-	
			Full	-	-5	-	
Logic supply current <sup>e</sup>	$I_L$		Room	0.00002	-	1	
			Full	-	-	5	
Ground current <sup>e</sup>	$I_{GND}$		Room	-0.00003	-1	-	
			Full	-	-5	-	



SPECIFICATIONS (Single supply 5 V)								
PARAMETER	SYMBOL	TEST CONDITIONS UNLESS OTHERWISE SPECIFIED V+ = 5 V, V- = 0 V VL = 5 V, VIN = 2.4 V, 0.8 V f	TEMP. b	TYP. c	D SUFFIX LIMITS -40 °C to +85 °C		UNIT	
					MIN. d	MAX. d		
<b>Analog Switch</b>								
Analog signal range e	VANALOG		Full	-	0	5	V	
Drain-source on-resistance e	RDS(on)	V+ = 4.5 V, INO, INC = 5 mA VCOM = 1 V, 3.5 V DG417LE / DG418LE only	Room	12	-	16	Ω	
			Full	-	-	18		
		V+ = 4.5 V, INO, INC = 5 mA VCOM = 1 V, 3.5 V DG419LE only	Room	24	-	35		
			Full	-	-	37		
Switch off leakage current a	INO(off) INC(off)	V+ = 5.5 V, V- = 0 V VCOM = 1 V / 4.5 V VNO, VNC = 4.5 V / 1 V	Room	± 0.002	-1	1	nA	
			Full	-	-10	10		
	ICOM(off)		Room	± 0.001	-1	1		
			Full	-	-10	10		
Switch on leakage current a	ICOM(on)	V+ = 5.5 V, V- = 0 V VNO, VNC = VCOM = 1 V / 4.5 V	Room	± 0.003	-1	1		
			Full	-	-10	10		
<b>Digital Control</b>								
Input current a	IINL or IINH			Full	0.02	-1	1	μA
<b>Dynamic Characteristics</b>								
Turn-on time e	tON	RL = 300 Ω, CL = 35 pF VNO, VNC = 3.5 V	Room	29	-	46	ns	
			Full	-	-	49		
Turn-off time e	tOFF		Room	16	-	28		
			Full	-	-	32		
Break-before-make time e	tBBM	DG419LE only, VNO, VNC = 3.5 V RL = 300 Ω, CL = 35 pF	Room	16	-	-		
Charge injection e	QINJ	VGEN = 0 V, RGEN = 0 Ω, CL = 1 nF	Room	10	-	-	pC	
Off-isolation e	OIRR	RL = 50 Ω, CL = 5 pF, f = 1 MHz	Room	-68	-	-	dB	
Channel-to-channel crosstalk e	XTALK		Room	-72	-	-		
Source off capacitance e	CNO(off) CNC(off)	VIN = 0 V or V+, f = 1 MHz DG417LE / DG418LE only	Room	13	-	-	pF	
Drain-on capacitance e	CON		Room	34	-	-		
Source off capacitance e	CNO(off) CNC(off)	VIN = 0 V or V+, f = 1 MHz DG419LE only	Room	7	-	-		
Drain-on capacitance e	CON		Room	22	-	-		
<b>Power Supplies</b>								
Positive supply current e	I+	VIN = 0 V or VL	Room	0.00006	-	1	μA	
			Full	-	-	5		
Negative supply current e	I-		Room	-0.00006	-1	-		
			Full	-	-5	-		
Logic supply current e	IL		Room	0.00002	-	1		
			Full	-	-	5		
Ground current e	IGND		Room	-0.00002	-1	-		
			Full	-	-5	-		



SPECIFICATIONS (Single supply 3 V)							
PARAMETER	SYMBOL	TEST CONDITIONS UNLESS OTHERWISE SPECIFIED $V_+ = 3\text{ V}$ , $V_- = 0\text{ V}$ $V_L = 3\text{ V}$ , $V_{IN} = 2\text{ V}$ , $0.4\text{ V}^f$	TEMP. <sup>b</sup>	TYP. <sup>c</sup>	D SUFFIX LIMITS -40 °C to +85 °C		UNIT
					MIN. <sup>d</sup>	MAX. <sup>d</sup>	
<b>Analog Switch</b>							
Analog signal range <sup>e</sup>	$V_{ANALOG}$		Full	-	0	3	V
Drain-source on-resistance	$R_{DS(on)}$	$V_+ = 2.7\text{ V}$ , $V_- = 0\text{ V}$ $I_{NO}$ , $I_{NC} = 5\text{ mA}$ , $V_{COM} = 0.5\text{ V}$ , $2.2\text{ V}$ DG417LE / DG418LE only	Room	22	-	34	$\Omega$
			Full	-	-	38	
			Room	43	-	68	
			Full	-	-	75	
Switch off leakage current <sup>a</sup>	$I_{NO(off)}$ $I_{NC(off)}$	$V_+ = 3.3\text{ V}$ , $V_- = 0\text{ V}$ $V_{COM} = 1\text{ V}$ , $2\text{ V}$ , $V_{NO}$ , $V_{NC} = 2\text{ V}$ , $1\text{ V}$	Room	$\pm 0.002$	-1	1	nA
			Full	-	-10	10	
	Room		$\pm 0.001$	-1	1		
	Full		-	-10	10		
Channel on leakage current <sup>a</sup>	$I_{COM(on)}$	$V_+ = 3.3\text{ V}$ , $V_- = 0\text{ V}$ $V_{NO}$ , $V_{NC} = V_{COM} = 1\text{ V}$ , $2\text{ V}$	Room	$\pm 0.002$	-1	1	
			Full	-	-10	10	
<b>Digital Control</b>							
Input current <sup>a</sup>	$I_{INL}$ or $I_{INH}$		Full	0.02	-1	1	$\mu\text{A}$
<b>Dynamic Characteristics</b>							
Turn-on time	$t_{ON}$	$R_L = 300\ \Omega$ , $C_L = 35\text{ pF}$ $V_{NO}$ , $V_{NC} = 1.5\text{ V}$	Room	59	-	77	ns
			Full	-	-	81	
Turn-off time	$t_{OFF}$		Room	33	-	54	
			Full	-	-	69	
Break-before-make time <sup>e</sup>	$t_{BBM}$	DG419LE only, $V_{NO}$ , $V_{NC} = 1.5\text{ V}$ $R_L = 300\ \Omega$ , $C_L = 35\text{ pF}$	Room	31	-	-	
Charge injection <sup>e</sup>	$Q_{INJ}$	$V_{GEN} = 0\text{ V}$ , $R_{GEN} = 0\ \Omega$ , $C_L = 10\text{ nF}$	Room	6	-	-	pC
Off-isolation <sup>e</sup>	OIRR	$R_L = 50\ \Omega$ , $C_L = 5\text{ pF}$ , $f = 1\text{ MHz}$	Room	-68	-	-	dB
Channel-to-channel crosstalk <sup>e</sup>	$X_{TALK}$		Room	-71	-	-	
Source off capacitance <sup>e</sup>	$C_{NO(off)}$ $C_{NC(off)}$	$V_{IN} = 0\text{ V}$ or $V_+$ , $f = 1\text{ MHz}$ DG417LE / DG418LE only	Room	14	-	-	pF
Channel on capacitance <sup>e</sup>	$C_{D(on)}$		Room	35	-	-	
Source off capacitance <sup>e</sup>	$C_{NO(off)}$ $C_{NC(off)}$	$V_{IN} = 0\text{ V}$ or $V_+$ , $f = 1\text{ MHz}$ DG419LE only	Room	8	-	-	
Channel on capacitance <sup>e</sup>	$C_{D(on)}$		Room	23	-	-	
<b>Power Supplies</b>							
Positive supply current <sup>e</sup>	$I_+$	$V_{IN} = 0\text{ V}$ or $V_L$	Room	0.00005	-	1	$\mu\text{A}$
			Full	-	-	5	
Negative supply current <sup>e</sup>	$I_-$		Room	-0.00007	-1	-	
			Full	-	-5	-	
Logic supply current <sup>e</sup>	$I_L$		Room	0.00002	-	1	
			Full	-	-	5	
Ground current <sup>e</sup>	$I_{GND}$		Room	-0.00002	-1	-	
			Full	-	-5	-	

**Notes**

- a. Leakage parameters are guaranteed by worst case test condition and not subject to production test
- b. Room = 25 °C, full = as determined by the operating temperature suffix
- c. Typical values are for DESIGN AID ONLY, not guaranteed nor subject to production testing
- d. The algebraic convention whereby the most negative value is a minimum and the most positive a maximum, is used in this datasheet
- e. Guaranteed by design, not subject to production test
- f.  $V_{IN}$  = input voltage to perform proper function



TYPICAL CHARACTERISTICS (25 °C, unless otherwise noted)

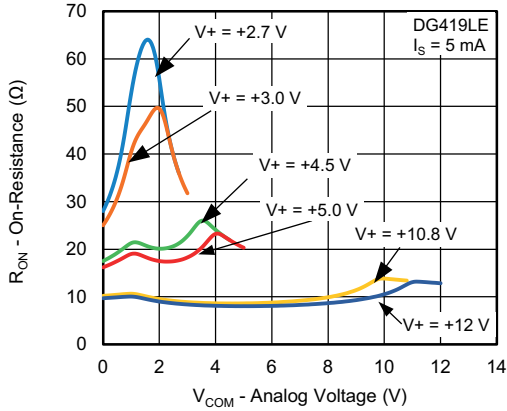

R<sub>DS(on)</sub> vs. V<sub>COM</sub> and Supply Voltage

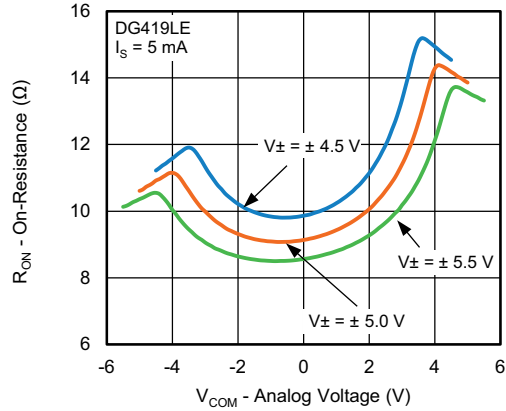

R<sub>DS(on)</sub> vs. V<sub>COM</sub> and Supply Voltage

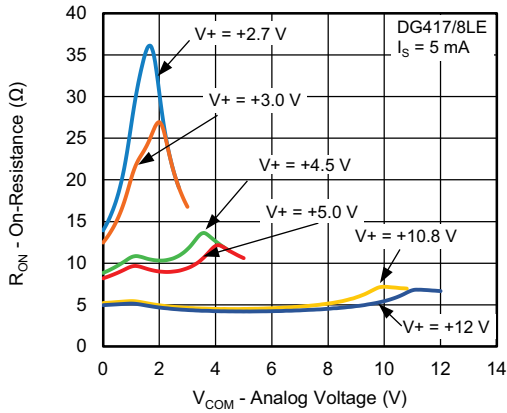

R<sub>DS(on)</sub> vs. V<sub>COM</sub> and Supply Voltage

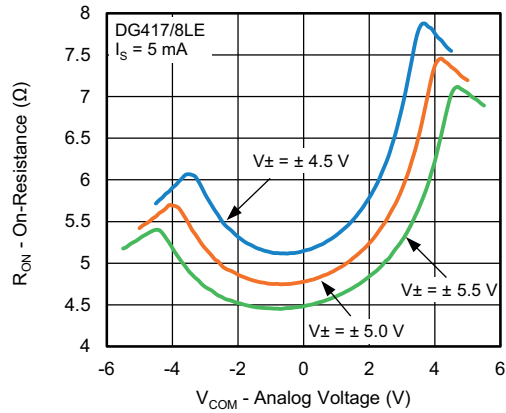

R<sub>DS(on)</sub> vs. V<sub>COM</sub> and Supply Voltage

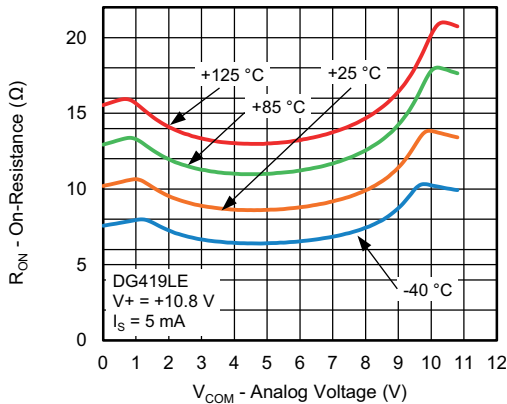

R<sub>DS(on)</sub> vs. Analog Voltage and Temperature

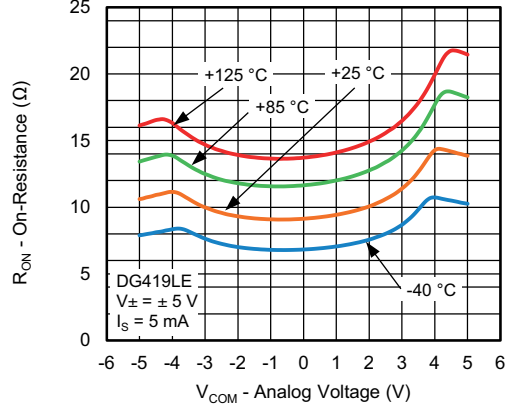

R<sub>DS(on)</sub> vs. Analog Voltage and Temperature



## TYPICAL CHARACTERISTICS (25 °C, unless otherwise noted)

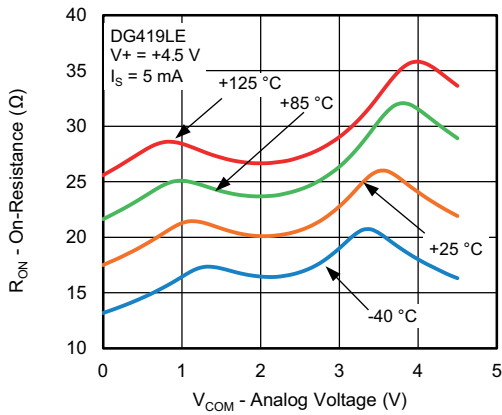

**R<sub>DS(on)</sub> vs. Analog Voltage and Temperature**

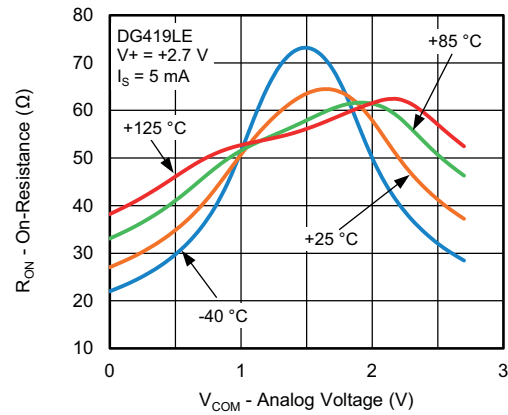

**R<sub>DS(on)</sub> vs. Analog Voltage and Temperature**

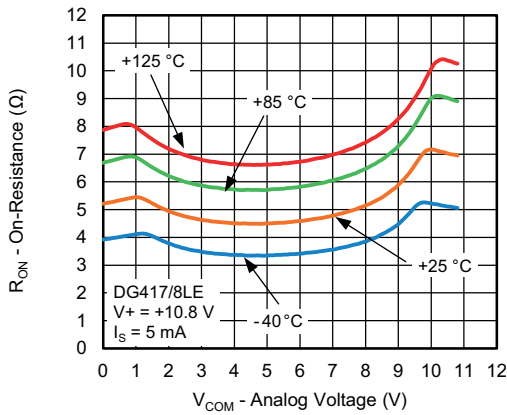

**R<sub>DS(on)</sub> vs. Analog Voltage and Temperature**

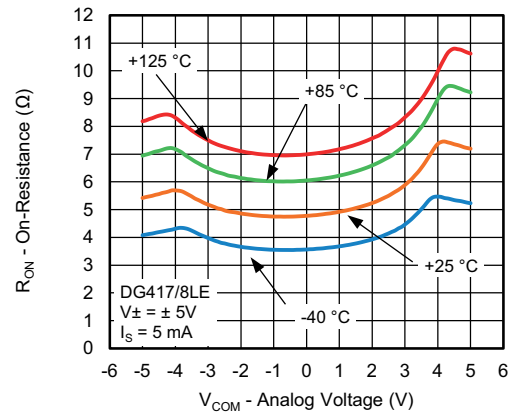

**R<sub>DS(on)</sub> vs. Analog Voltage and Temperature**

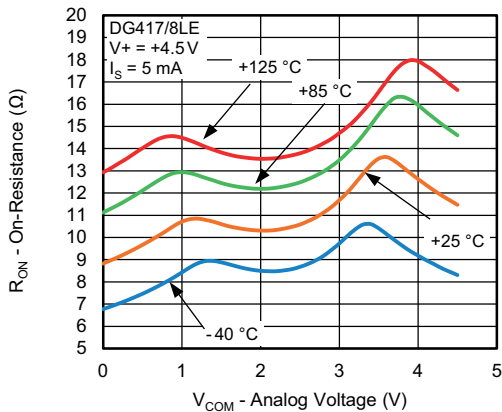

**R<sub>DS(on)</sub> vs. Analog Voltage and Temperature**

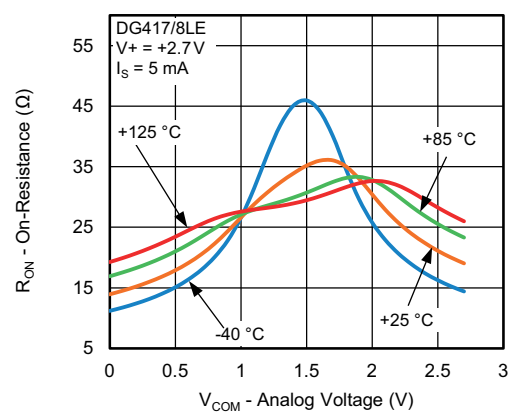

**R<sub>DS(on)</sub> vs. Analog Voltage and Temperature**



TYPICAL CHARACTERISTICS (25 °C, unless otherwise noted)

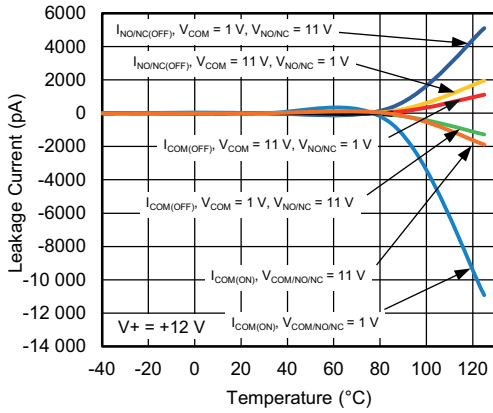

Leakage Current vs. Temperature

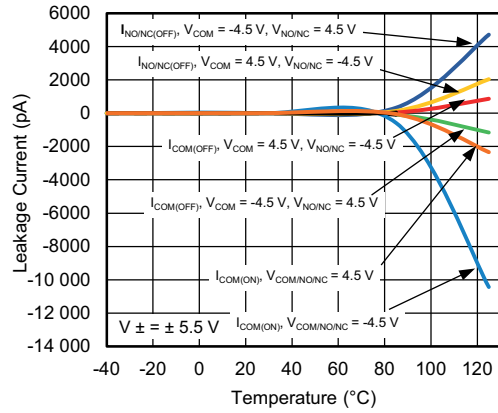

Leakage Current vs. Temperature

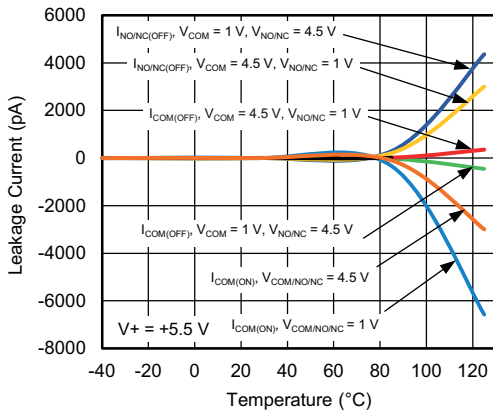

Leakage Current vs. Temperature

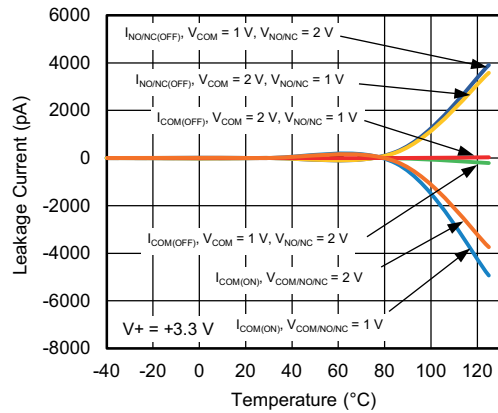

Leakage Current vs. Temperature

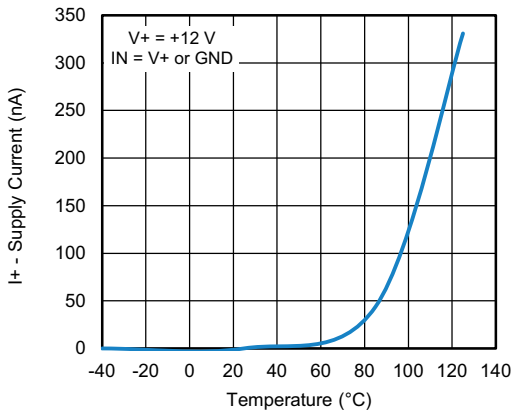

Supply Current vs. Temperature

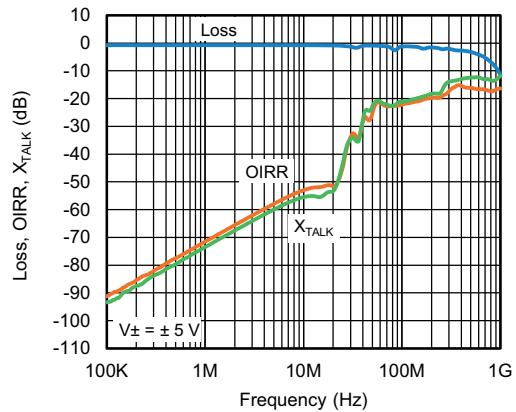

Insertion Loss, Off-Isolation Crosstalk vs. Frequency



**TYPICAL CHARACTERISTICS** (25 °C, unless otherwise noted)

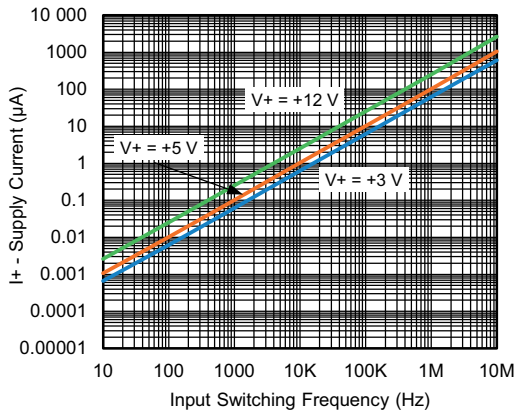

**Supply Current vs. Input Switching Frequency**

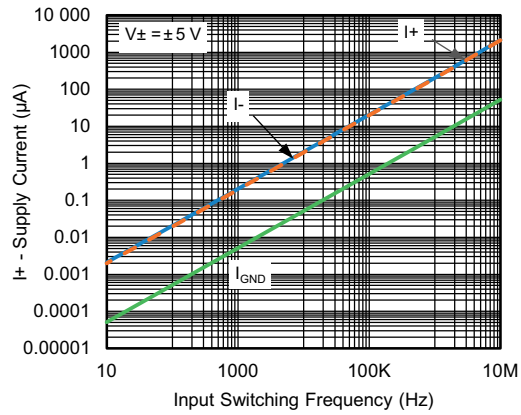

**Supply Current vs. Input Switching Frequency**

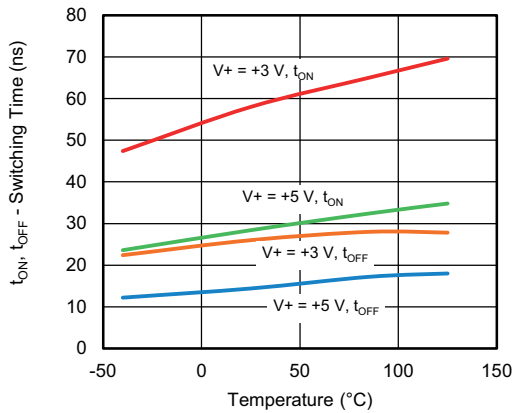

**Switching Time vs. Temperature**

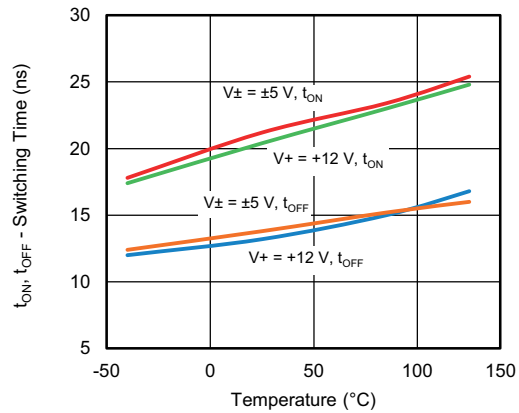

**Switching Time vs. Temperature**

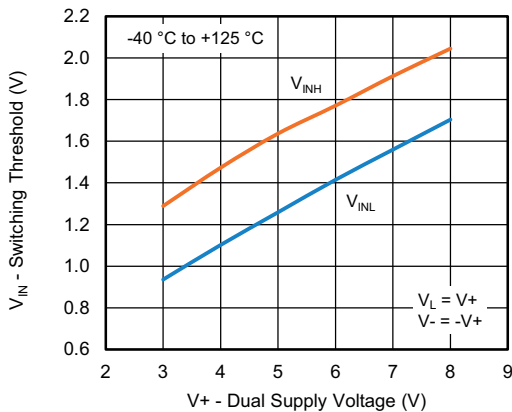

**Switching Threshold vs. Dual Supply Voltage**

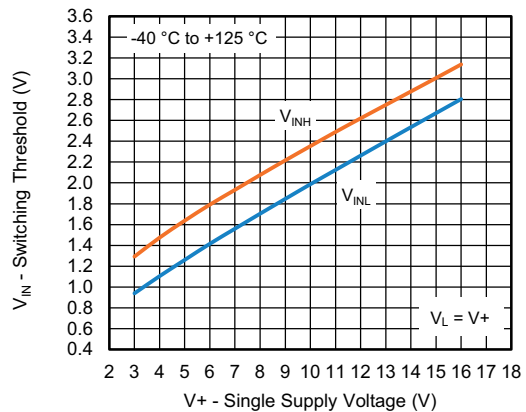

**Switching Threshold vs. Single Supply Voltage**



TYPICAL CHARACTERISTICS (25 °C, unless otherwise noted)

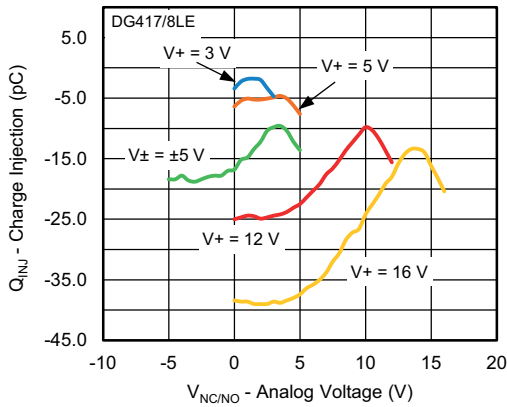

Charge Injection vs. Analog Voltage

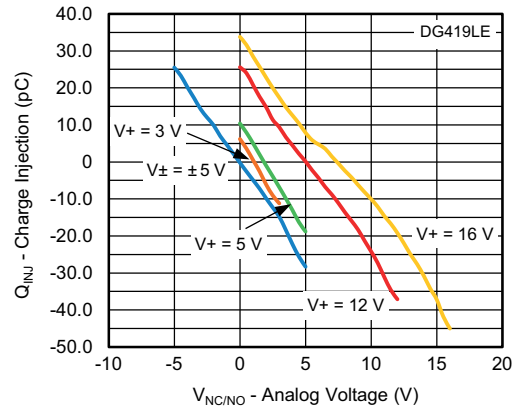

Charge Injection vs. Analog Voltage

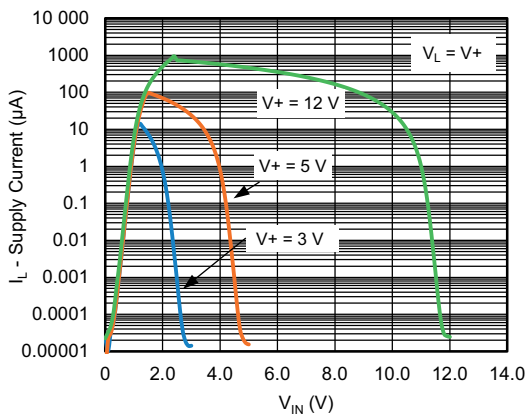

Supply Current vs. Enable Input Voltage

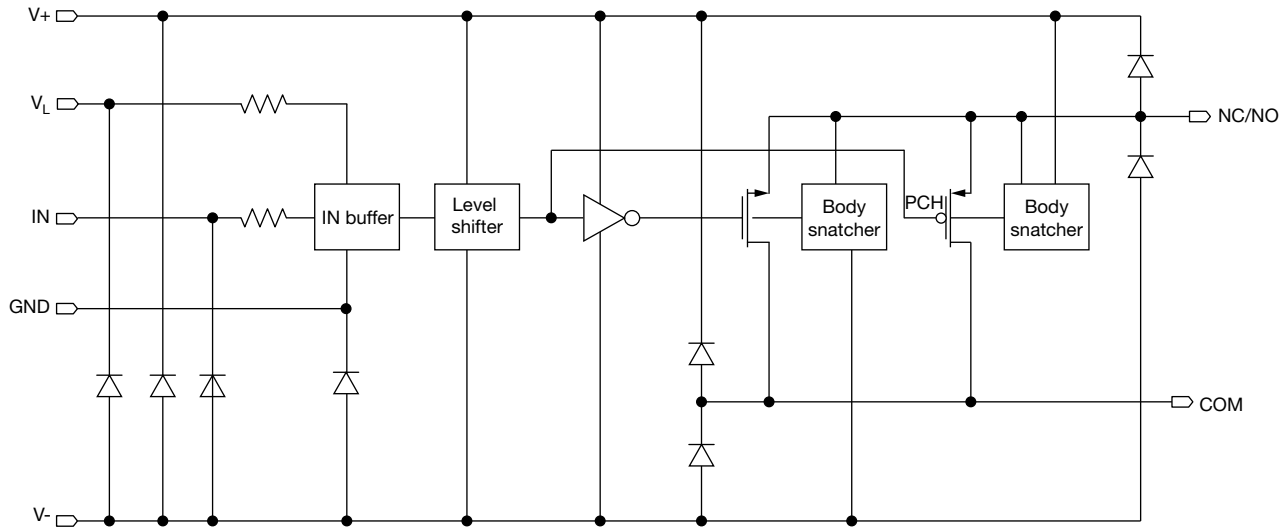
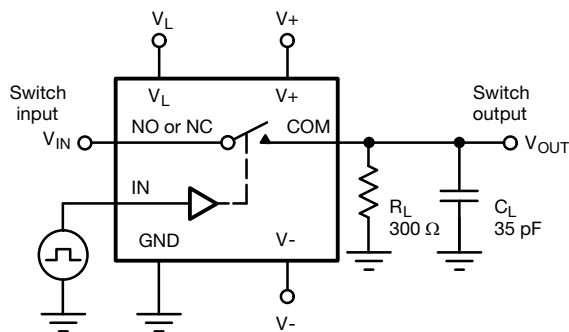
**SCHEMATIC DIAGRAM** (Typical channel)

**TEST CIRCUITS**

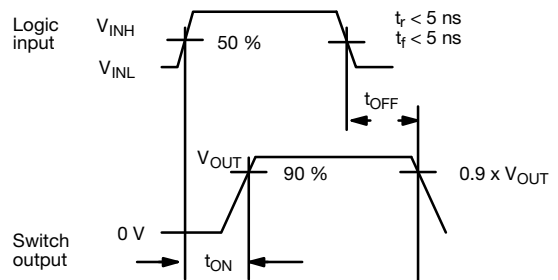
 $C_L$  (includes fixture and stray capacitance)

$$V_{OUT} = V_{IN} \frac{R_L}{R_L + R_{ON}}$$

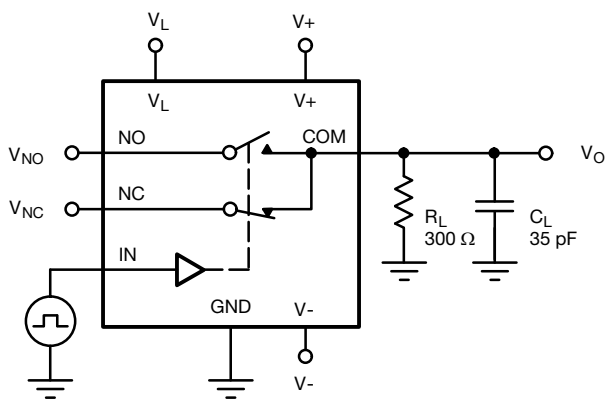
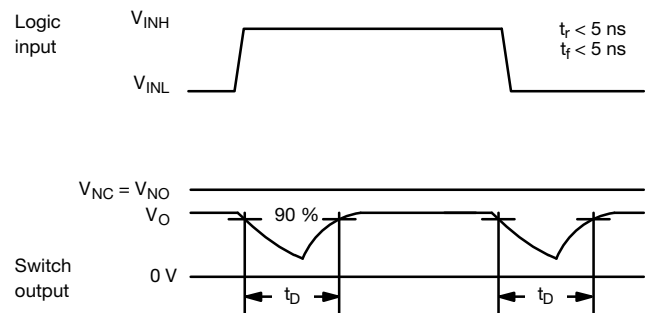
**Note**

- Logic input waveform is inverted for switches that have the opposite logic sense control

**Fig. 1 - Switching Time**

 $C_L$  (includes fixture and stray capacitance)

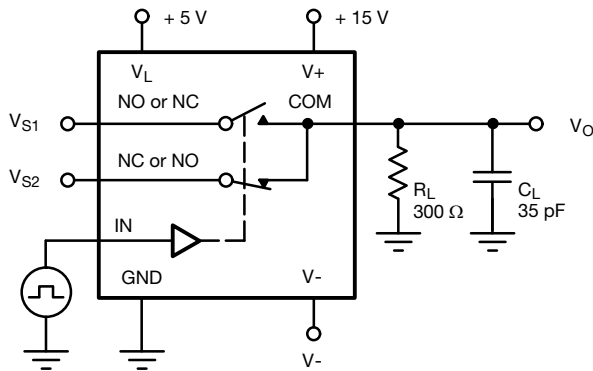
**Fig. 2 - Break-Before-Make (DG419LE)**

## TEST CIRCUITS



$C_L$  (includes fixture and stray capacitance)

$$V_O = V_S \frac{R_L}{R_L + R_{ON}}$$

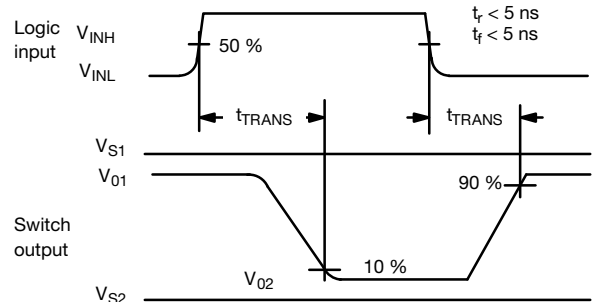
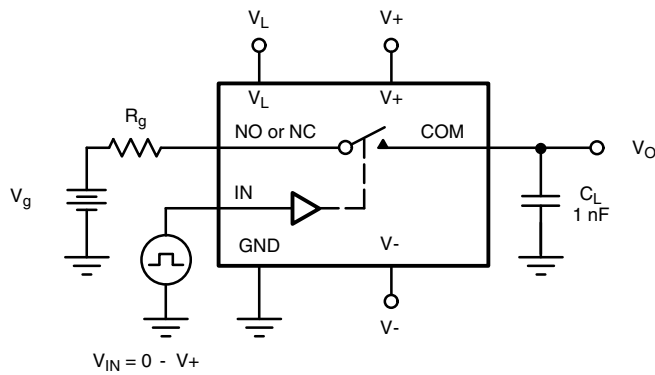
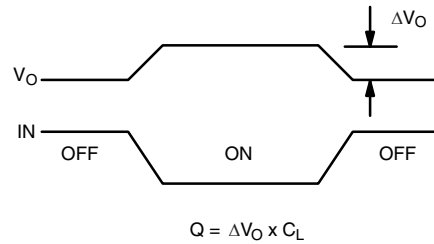

Fig. 3 - Transition Time (DG419LE)



$V_{IN} = 0 - V+$



IN dependent on switch configuration input polarity determined by sense of switch.

Fig. 4 - Charge Injection

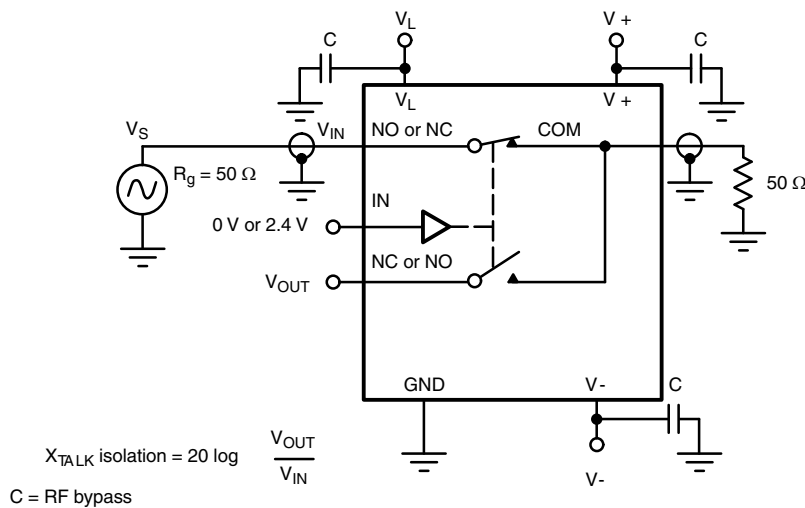

$X_{TALK} \text{ isolation} = 20 \log \frac{V_{OUT}}{V_{IN}}$   
 $C = \text{RF bypass}$

Fig. 5 - Crosstalk (DG419LE)

TEST CIRCUITS

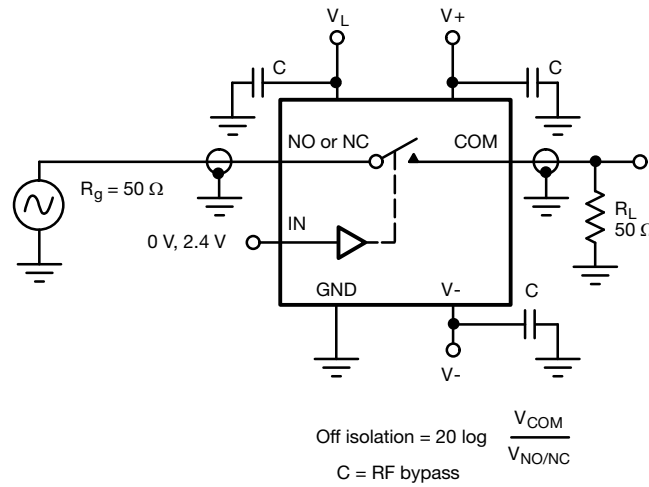

Fig. 6 - Off Isolation

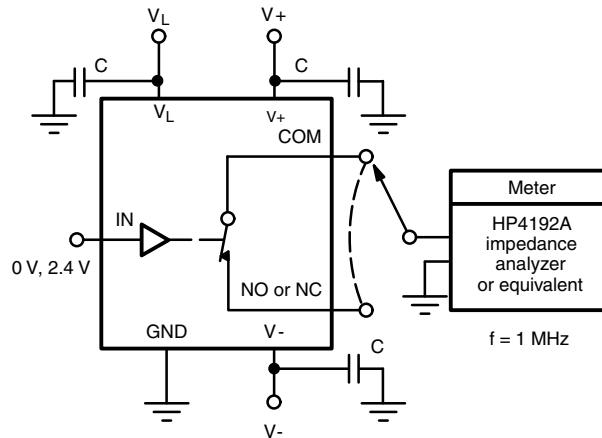

Fig. 7 - Channel Capacitances



PRODUCT SUMMARY						
Part number	DG417LE	DG417LE	DG418LE	DG418LE	DG419LE	DG419LE
Status code	2	2	2	2	2	2
Configuration	SPST x 1, NC	SPST x 1, NC	SPST x 1, NO	SPST x 1, NO	SPDT x 1	SPDT x 1
Single supply min. (V)	3	3	3	3	3	3
Single supply max. (V)	16	16	16	16	16	16
Dual supply min. (V)	3	3	3	3	3	3
Dual supply max. (V)	8	8	8	8	8	8
On-resistance ( $\Omega$ )	6	6	6	6	12	12
Charge injection (pC)	-17	-17	-17	-17	-17	-17
Source on capacitance (pF)	33	33	33	33	29	29
Source off capacitance (pF)	11	11	11	11	6	6
Leakage switch on typ. (nA)	0.003	0.003	0.003	0.003	0.003	0.003
Leakage switch off max. (nA)	2	2	2	2	2	2
-3 dB bandwidth (MHz)	-	-	-	-	-	-
Package	SO-8 (narrow) AS	MSOP-8	SO-8 (narrow) AS	MSOP-8	SO-8 (narrow) AS	MSOP-8
Functional circuit / applications	Multi purpose, instrumentation, medical and healthcare, portable	Multi purpose, instrumentation, medical and healthcare, portable	Multi purpose, instrumentation, medical and healthcare, portable	Multi purpose, instrumentation, medical and healthcare, portable	Multi purpose, instrumentation, medical and healthcare, portable	Multi purpose, instrumentation, medical and healthcare, portable
Interface	Parallel	Parallel	Parallel	Parallel	Parallel	Parallel
Single supply operation	Yes	Yes	Yes	Yes	Yes	Yes
Dual supply operation	Yes	Yes	Yes	Yes	Yes	Yes
Turn on time max. (ns)	38	38	38	38	38	38
Crosstalk and off isolation	-68	-68	-68	-68	-68	-68

Vishay Siliconix maintains worldwide manufacturing capability. Products may be manufactured at one of several qualified locations. Reliability data for Silicon Technology and Package Reliability represent a composite of all qualified locations. For related documents such as package / tape drawings, part marking, and reliability data, see [www.vishay.com/ppg?76432](http://www.vishay.com/ppg?76432).

## SOIC (NARROW): 8-LEAD

JEDEC Part Number: MS-012

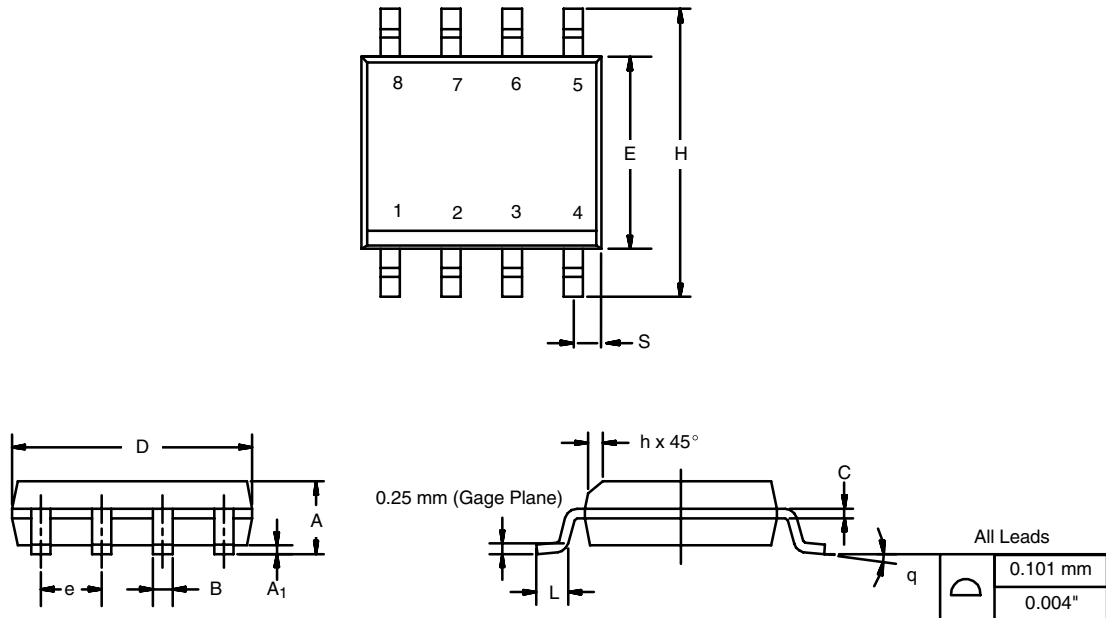

DIM	MILLIMETERS		INCHES	
	Min	Max	Min	Max
A	1.35	1.75	0.053	0.069
A <sub>1</sub>	0.10	0.20	0.004	0.008
B	0.35	0.51	0.014	0.020
C	0.19	0.25	0.0075	0.010
D	4.80	5.00	0.189	0.196
E	3.80	4.00	0.150	0.157
e	1.27 BSC		0.050 BSC	
H	5.80	6.20	0.228	0.244
h	0.25	0.50	0.010	0.020
L	0.50	0.93	0.020	0.037
q	0°	8°	0°	8°
S	0.44	0.64	0.018	0.026
ECN: C-06527-Rev. I, 11-Sep-06				
DWG: 5498				



### MSOP: 8-LEADS

JEDEC Part Number: MO-187, (Variation AA and BA)

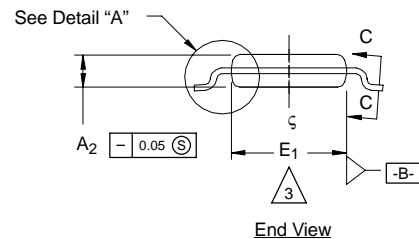
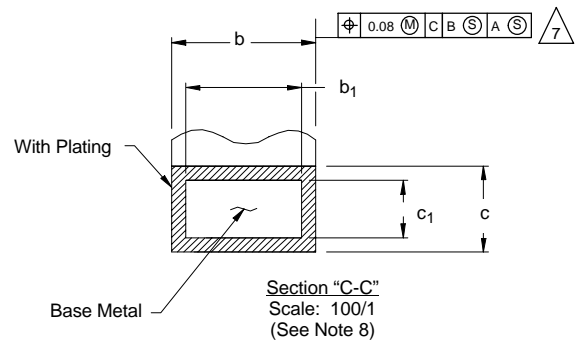
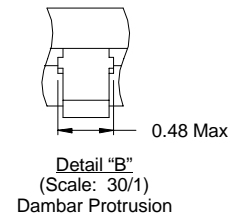
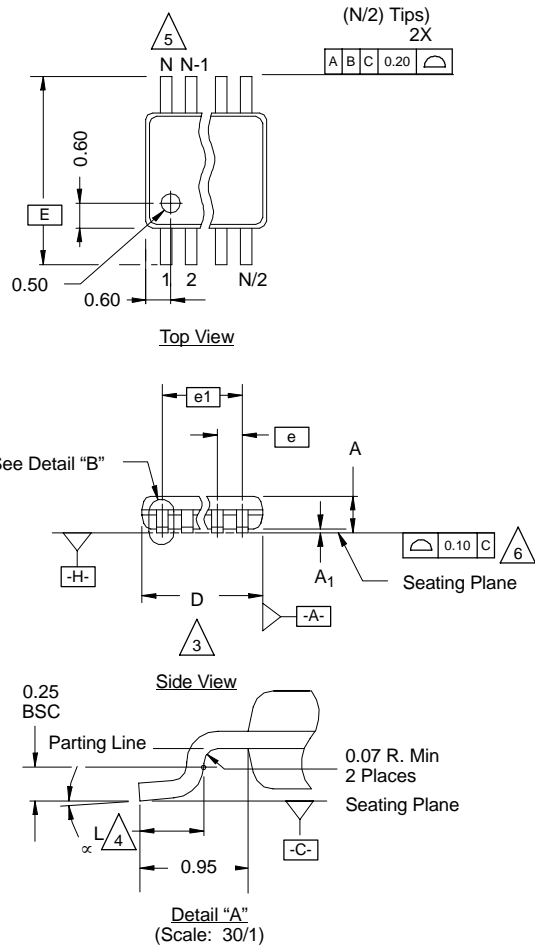

**NOTES:**

1. Die thickness allowable is  $0.203 \pm 0.0127$ .
2. Dimensioning and tolerances per ANSI.Y14.5M-1994.
3. Dimensions "D" and "E<sub>1</sub>" do not include mold flash or protrusions, and are measured at Datum plane [-H-], mold flash or protrusions shall not exceed 0.15 mm per side.
4. Dimension is the length of terminal for soldering to a substrate.
5. Terminal positions are shown for reference only.
6. Formed leads shall be planar with respect to one another within 0.10 mm at seating plane.
7. The lead width dimension does not include Dambar protrusion. Allowable Dambar protrusion shall be 0.08 mm total in excess of the lead width dimension at maximum material condition. Dambar cannot be located on the lower radius or the lead foot. Minimum space between protrusions and an adjacent lead to be 0.14 mm. See detail "B" and Section "C-C".
8. Section "C-C" to be determined at 0.10 mm to 0.25 mm from the lead tip.
9. Controlling dimension: millimeters.
10. This part is compliant with JEDEC registration MO-187, variation AA and BA.
11. Datums [-A-] and [-B-] to be determined Datum plane [-H-].
12. Exposed pad area in bottom side is the same as teh leadframe pad size.

**N = 8L**

Dim	MILLIMETERS			Note
	Min	Nom	Max	
<b>A</b>	-	-	1.10	
<b>A<sub>1</sub></b>	0.05	0.10	0.15	
<b>A<sub>2</sub></b>	0.75	0.85	0.95	
<b>b</b>	0.25	-	0.38	8
<b>b<sub>1</sub></b>	0.25	0.30	0.33	8
<b>c</b>	0.13	-	0.23	
<b>c<sub>1</sub></b>	0.13	0.15	0.18	
<b>D</b>	3.00 BSC			3
<b>E</b>	4.90 BSC			
<b>E<sub>1</sub></b>	2.90	3.00	3.10	3
<b>e</b>	0.65 BSC			
<b>e<sub>1</sub></b>	1.95 BSC			
<b>L</b>	0.40	0.55	0.70	4
<b>N</b>	8			5
$\alpha$	0°	4°	6°	

ECN: T-02080—Rev. C, 15-Jul-02  
 DWG: 5867

## RECOMMENDED MINIMUM PADS FOR SO-8

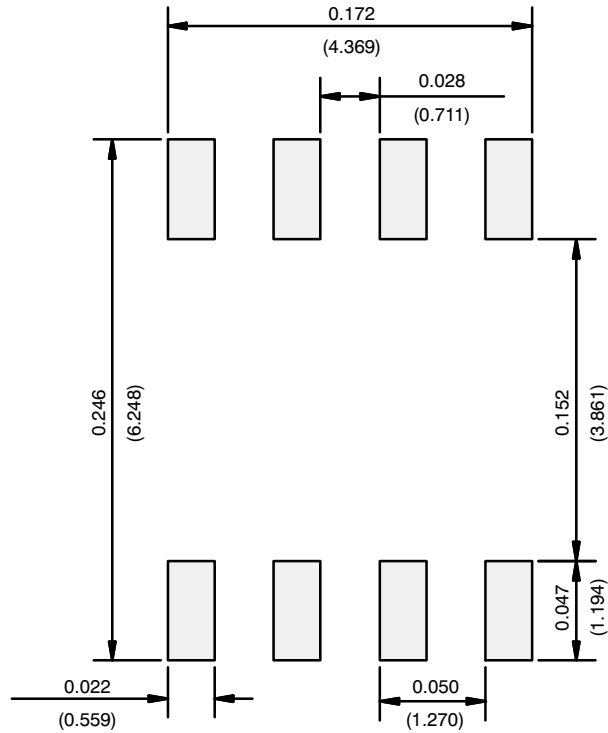

Recommended Minimum Pads  
Dimensions in Inches/(mm)

[Return to Index](#)



## **Disclaimer**

ALL PRODUCT, PRODUCT SPECIFICATIONS AND DATA ARE SUBJECT TO CHANGE WITHOUT NOTICE TO IMPROVE RELIABILITY, FUNCTION OR DESIGN OR OTHERWISE.

Vishay Intertechnology, Inc., its affiliates, agents, and employees, and all persons acting on its or their behalf (collectively, "Vishay"), disclaim any and all liability for any errors, inaccuracies or incompleteness contained in any datasheet or in any other disclosure relating to any product.

Vishay makes no warranty, representation or guarantee regarding the suitability of the products for any particular purpose or the continuing production of any product. To the maximum extent permitted by applicable law, Vishay disclaims (i) any and all liability arising out of the application or use of any product, (ii) any and all liability, including without limitation special, consequential or incidental damages, and (iii) any and all implied warranties, including warranties of fitness for particular purpose, non-infringement and merchantability.

Statements regarding the suitability of products for certain types of applications are based on Vishay's knowledge of typical requirements that are often placed on Vishay products in generic applications. Such statements are not binding statements about the suitability of products for a particular application. It is the customer's responsibility to validate that a particular product with the properties described in the product specification is suitable for use in a particular application. Parameters provided in datasheets and / or specifications may vary in different applications and performance may vary over time. All operating parameters, including typical parameters, must be validated for each customer application by the customer's technical experts. Product specifications do not expand or otherwise modify Vishay's terms and conditions of purchase, including but not limited to the warranty expressed therein.

Hyperlinks included in this datasheet may direct users to third-party websites. These links are provided as a convenience and for informational purposes only. Inclusion of these hyperlinks does not constitute an endorsement or an approval by Vishay of any of the products, services or opinions of the corporation, organization or individual associated with the third-party website. Vishay disclaims any and all liability and bears no responsibility for the accuracy, legality or content of the third-party website or for that of subsequent links.

Vishay products are not designed for use in life-saving or life-sustaining applications or any application in which the failure of the Vishay product could result in personal injury or death unless specifically qualified in writing by Vishay. Customers using or selling Vishay products not expressly indicated for use in such applications do so at their own risk. Please contact authorized Vishay personnel to obtain written terms and conditions regarding products designed for such applications.

No license, express or implied, by estoppel or otherwise, to any intellectual property rights is granted by this document or by any conduct of Vishay. Product names and markings noted herein may be trademarks of their respective owners.