

TIBPAL16L8-10C, TIBPAL16R4-10C, TIBPAL16R6-10C, TIBPAL16R8-10C TIBPAL16L8-12M, TIBPAL16R4-12M, TIBPAL16R6-12M, TIBPAL16R8-12M HIGH-PERFORMANCE *IMPACT-X*™ PAL® CIRCUITS

SRPS017A – D3023, MAY 1987 – REVISED DECEMBER 2010

- **High-Performance Operation:**
 - f_{max} (w/o feedback)
 - TIBPAL16R'-10C Series . . . 62.5 MHz Min
 - TIBPAL16R'-12M Series . . . 56 MHz Min
 - f_{max} (with feedback)
 - TIBPAL16R'-10C Series . . . 55.5 MHz Min
 - TIBPAL16R'-12M Series . . . 48 MHz Min
 - Propagation Delay
 - TIBPAL16L'-10C Series . . . 10 ns Max
 - TIBPAL16L'-12M Series . . . 12 ns Max
- **Functionally Equivalent, but Faster than, Existing 20-Pin PLDs**
- **Preload Capability on Output Registers Simplifies Testing**
- **Power-Up Clear on Registered Devices (All Register Outputs are Set Low, but Voltage Levels at the Output Pins Go High)**
- **Package Options Include Both Plastic and Ceramic Chip Carriers in Addition to Plastic and Ceramic DIPs**
- **Security Fuse Prevents Duplication**
- **Dependable Texas Instruments Quality and Reliability**

DEVICE	I INPUTS	3-STATE O OUTPUTS	REGISTERED Q OUTPUTS	I/O PORTS
PAL16L8	10	2	0	6
PAL16R4	8	0	4 (3-state buffers)	4
PAL16R6	8	0	6 (3-state buffers)	2
PAL16R8	8	0	8 (3-state buffers)	0

TIBPAL16L8'
C SUFFIX . . . J OR N PACKAGE
M SUFFIX . . . J PACKAGE

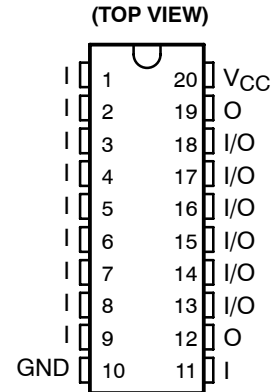

TIBPAL16L8'
C SUFFIX . . . FN PACKAGE
M SUFFIX . . . FK PACKAGE

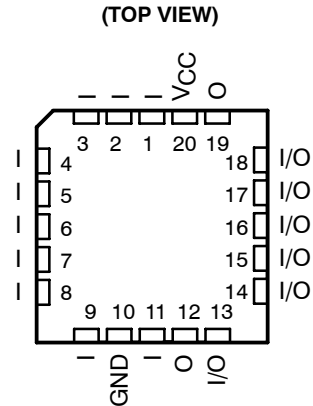

Pin assignments in operating mode

description

These programmable array logic devices feature high speed and functional equivalency when compared with currently available devices. These *IMPACT-X*™ circuits combine the latest Advanced Low-Power Schottky technology with proven titanium-tungsten fuses to provide reliable, high-performance substitutes for conventional TTL logic. Their easy programmability allows for quick design of custom functions and typically results in a more compact circuit board. In addition, chip carriers are available for further reduction in board space.

All of the register outputs are set to a low level during power up. Extra circuitry has been provided to allow loading of each register asynchronously to either a high or low state. This feature simplifies testing because the registers can be set to an initial state prior to executing the test sequence.

The TIBPAL16' C series is characterized from 0°C to 75°C. The TIBPAL16' M series is characterized for operation over the full military temperature range of -55°C to 125°C.

IMPACT-X is a trademark of Texas Instruments Incorporated.
PAL is a registered trademark of Advanced Micro Devices Inc.

PRODUCTION DATA information is current as of publication date. Products conform to specifications per the terms of Texas Instruments standard warranty. Production processing does not necessarily include testing of all parameters.



Copyright © 2010, Texas Instruments Incorporated

TIBPAL16R4-10C, TIBPAL16R6-10C, TIBPAL16R8-10C TIBPAL16R4-12M, TIBPAL16R6-12M, TIBPAL16R8-12M HIGH-PERFORMANCE *IMPACT-X*™ PAL® CIRCUITS

SRPS017A - D3023, MAY 1987 - REVISED DECEMBER 2010

TIBPAL16R4'
C SUFFIX . . . J OR N PACKAGE
M SUFFIX . . . J PACKAGE

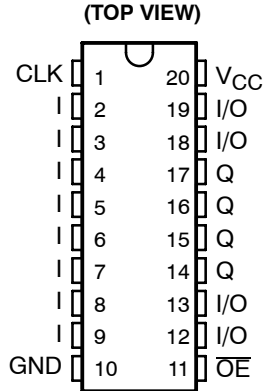

TIBPAL16R4'
C SUFFIX . . . FN PACKAGE
M SUFFIX . . . FK PACKAGE

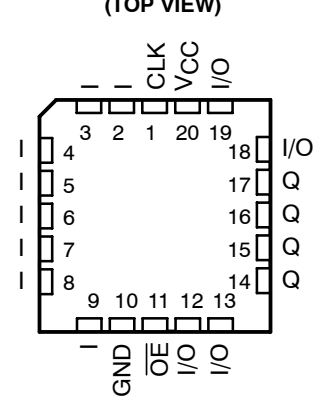

TIBPAL16R6'
C SUFFIX . . . J OR N PACKAGE
M SUFFIX . . . J PACKAGE

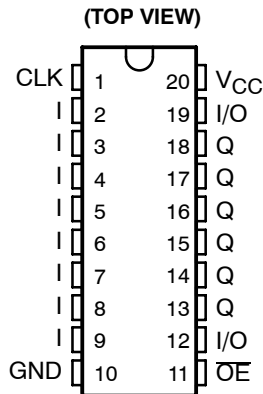

TIBPAL16R6'
C SUFFIX . . . FN PACKAGE
M SUFFIX . . . FK PACKAGE

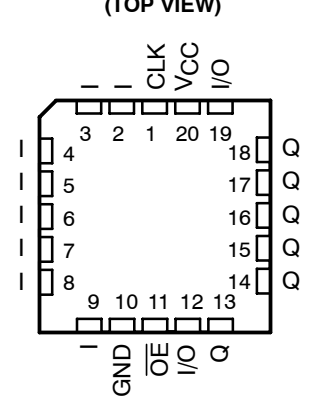

TIBPAL16R8'
C SUFFIX . . . J OR N PACKAGE
M SUFFIX . . . J PACKAGE

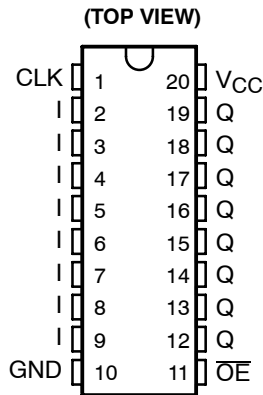

TIBPAL16R8'
C SUFFIX . . . FN PACKAGE
M SUFFIX . . . FK PACKAGE

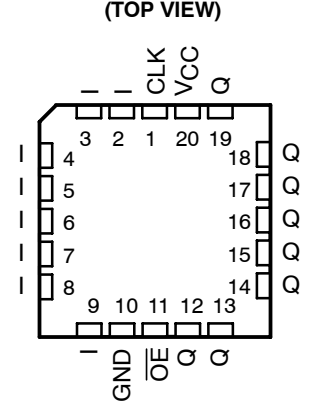

Pin assignments in operating mode

TIBPAL16L8-10C, TIBPAL16R4-10C TIBPAL16L8-12M, TIBPAL16R4-12M HIGH-PERFORMANCE *IMPACT-X*™ PAL® CIRCUITS

SRPS017A - D3023, MAY 1987 - REVISED DECEMBER 2010

functional block diagrams (positive logic)

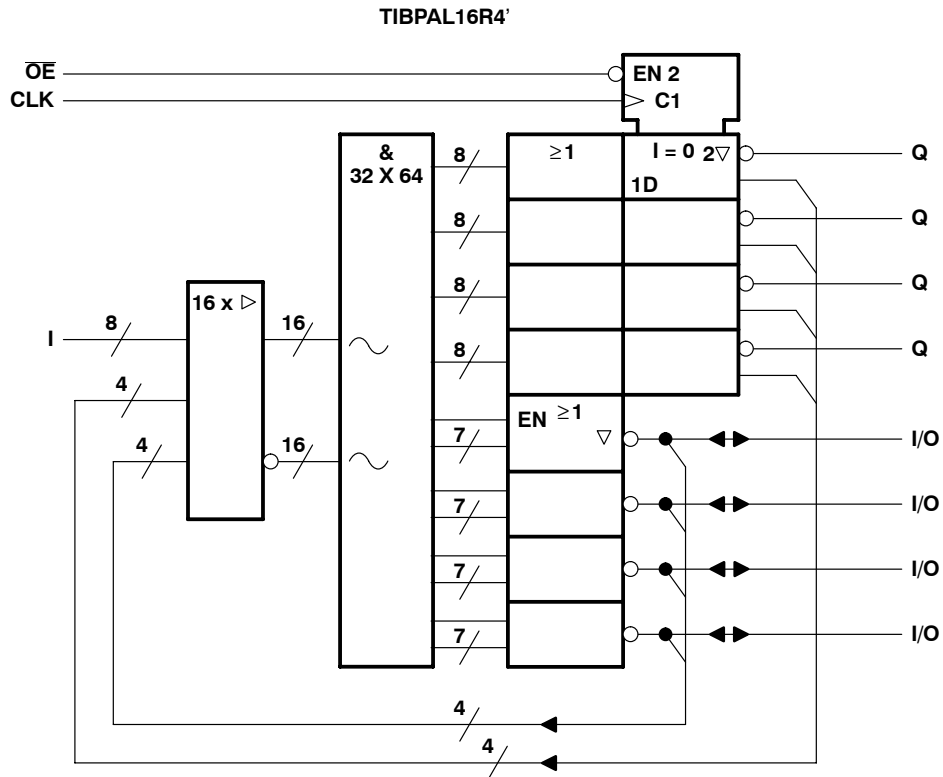
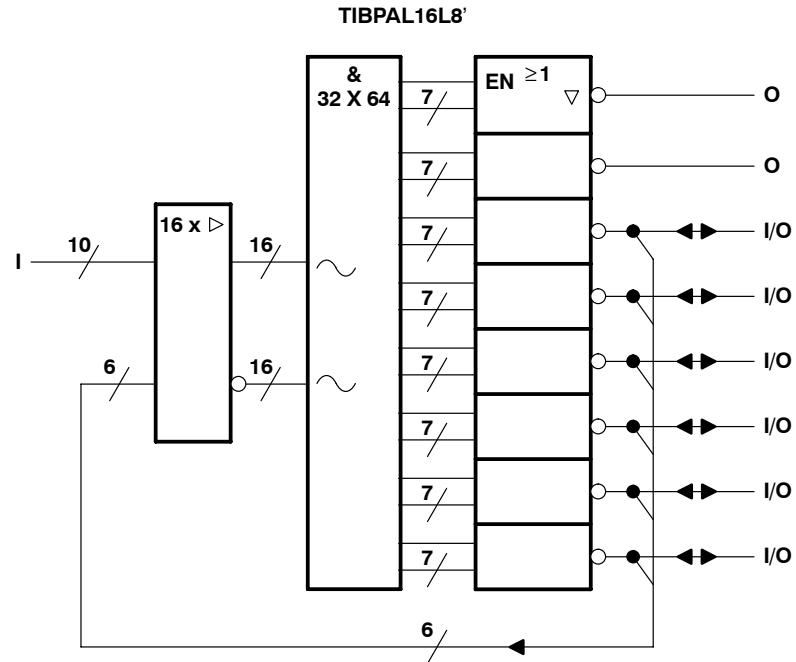

~ denotes fused inputs

TIBPAL16R6-10C, TIBPAL16R8-10C TIBPAL16R6-12M, TIBPAL16R8-12M HIGH-PERFORMANCE *IMPACT-X*™ PAL® CIRCUITS

SRPS017A - D3023, MAY 1987 - REVISED DECEMBER 2010

functional block diagrams (positive logic)

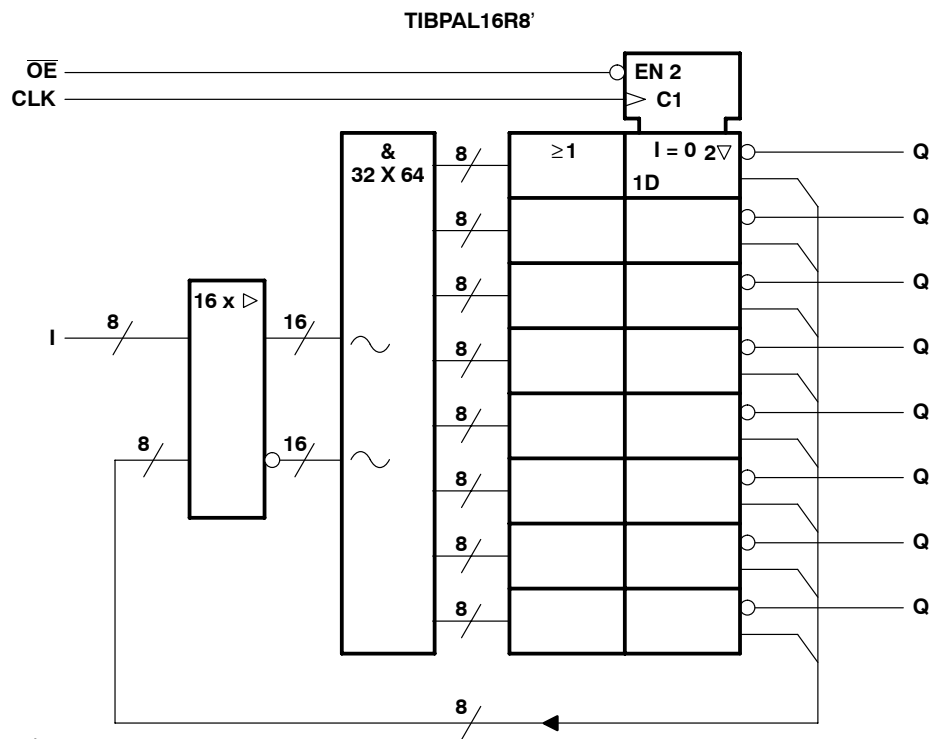
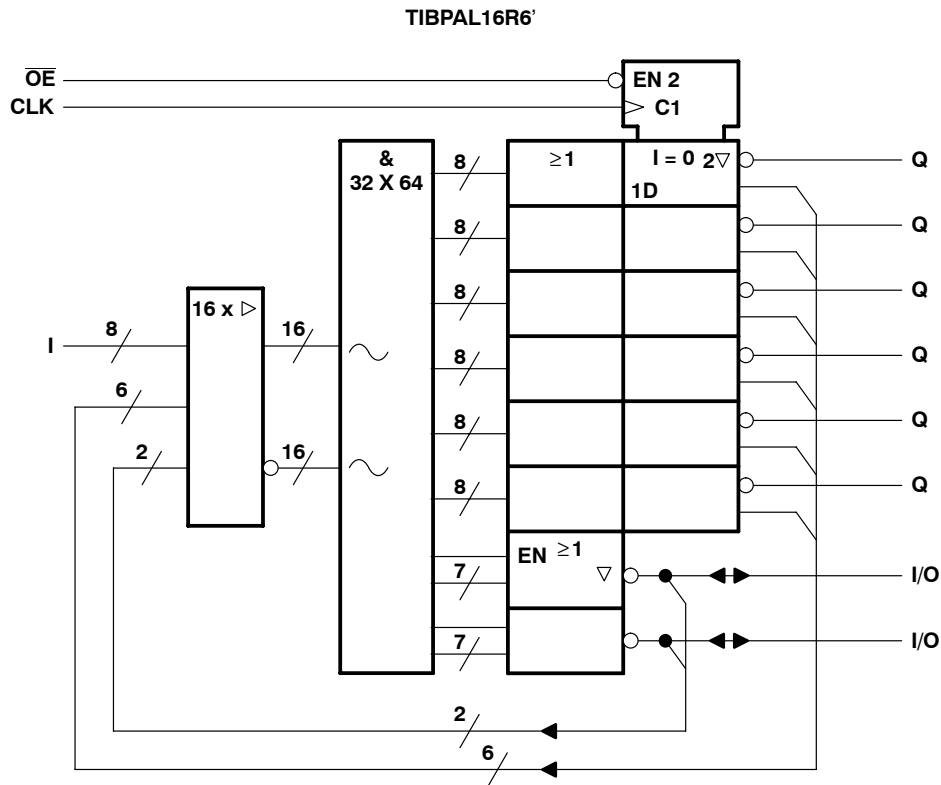

~ denotes fused inputs

TIBPAL16L8-10C TIBPAL16L8-12M HIGH-PERFORMANCE *IMPACT-X*™ PAL® CIRCUITS

SRPS017A - D3023, MAY 1987 - REVISED DECEMBER 2010

logic diagram (positive logic)

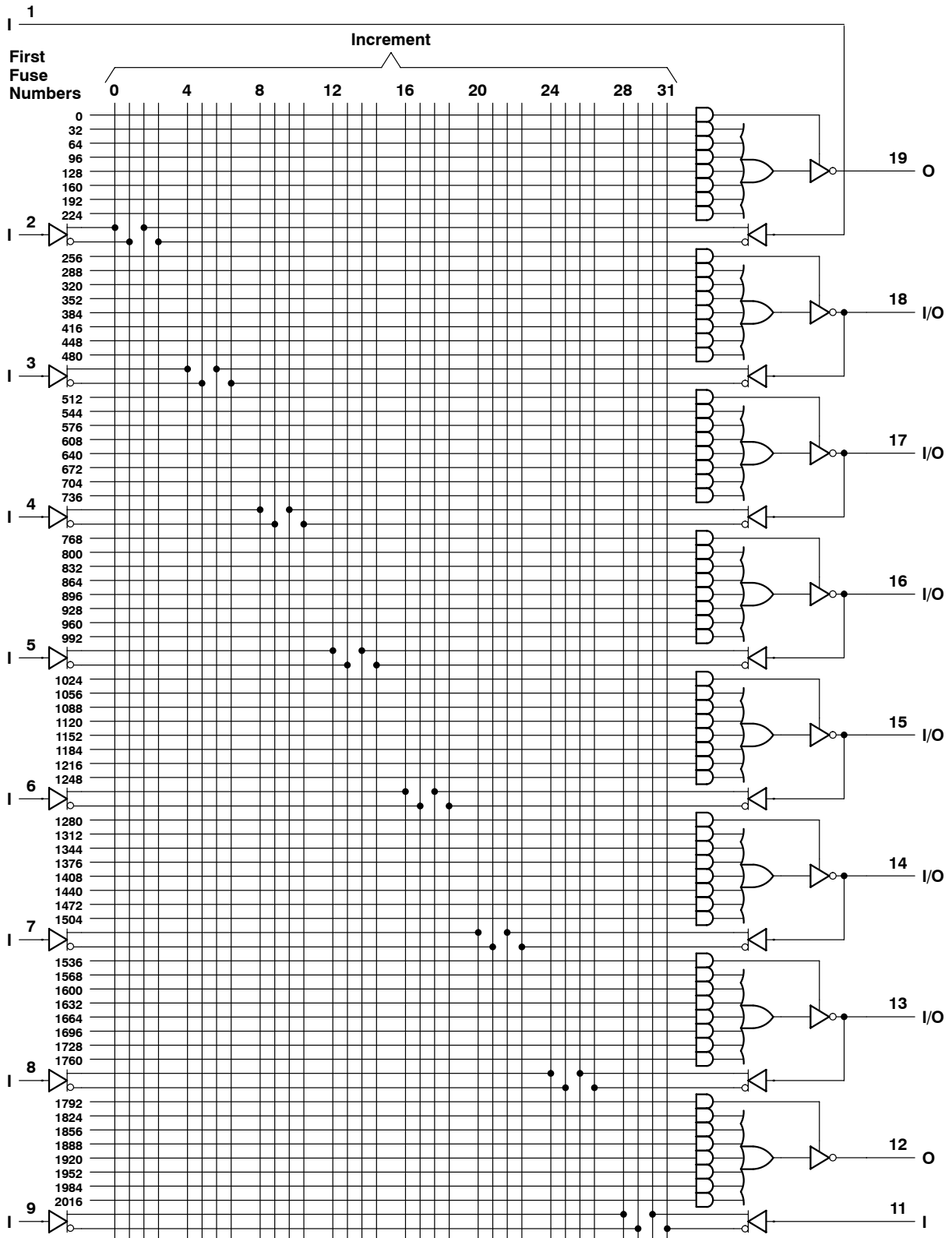

Fuse number = First fuse number + Increment



TIBPAL16R4-10C

TIBPAL16R4-12M

HIGH-PERFORMANCE *IMPACT-X*™ PAL® CIRCUITS

SRPS017A - D3023, MAY 1987 - REVISED DECEMBER 2010

logic diagram (positive logic)

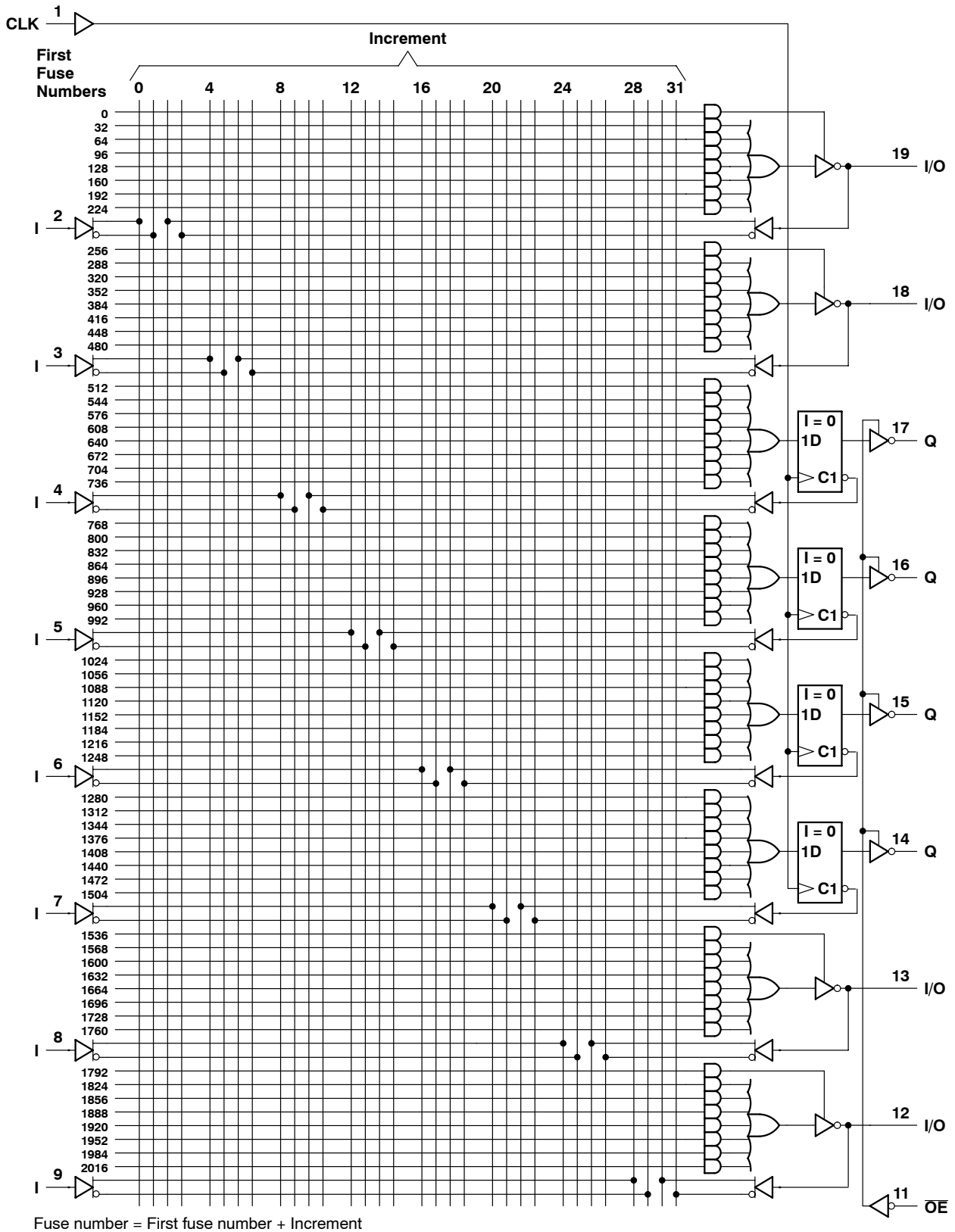

logic diagram (positive logic)

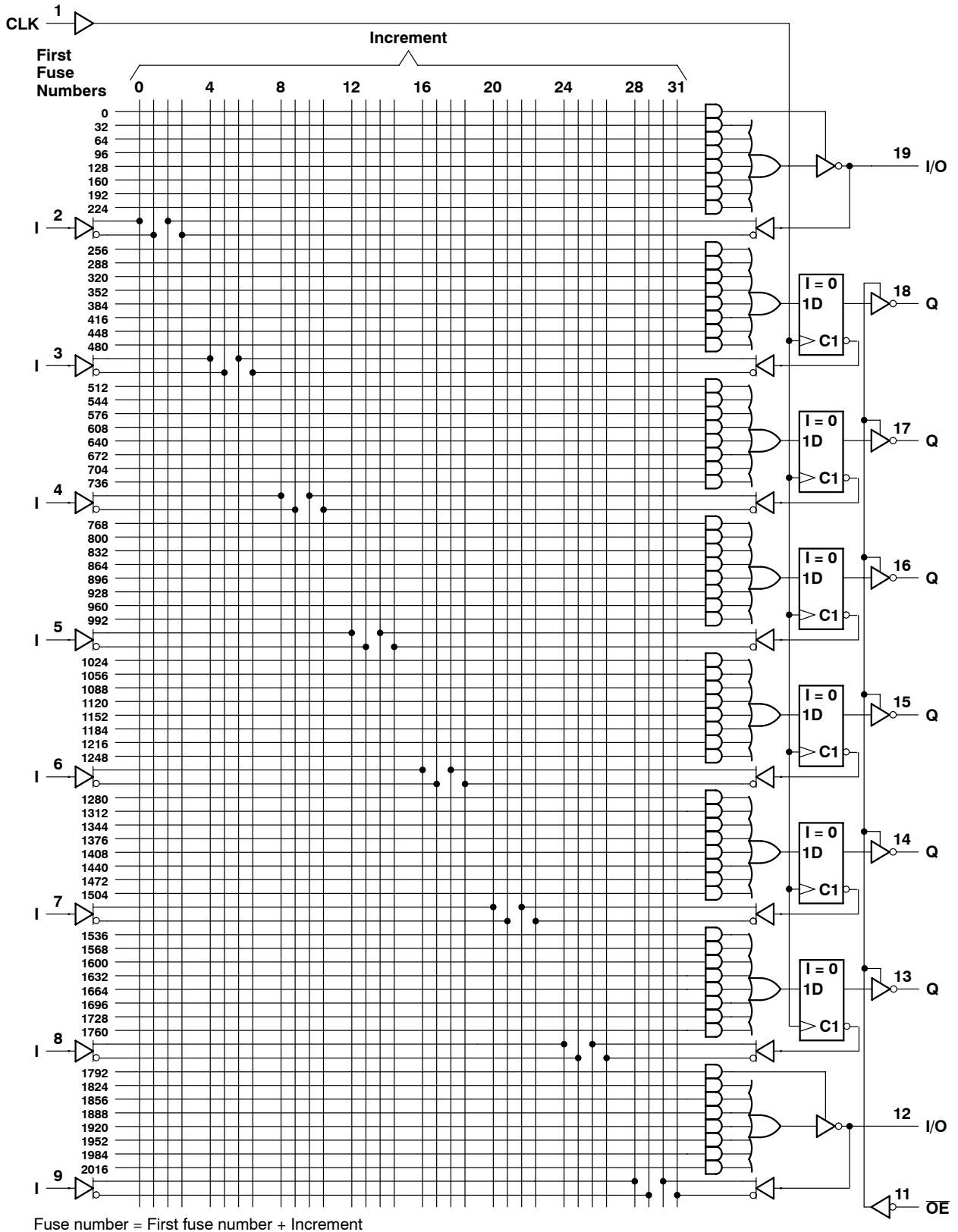

TIBPAL16R8-10C

TIBPAL16R8-12M

HIGH-PERFORMANCE *IMPACT-X*™ PAL® CIRCUITS

SRPS017A - D3023, MAY 1987 - REVISED DECEMBER 2010

logic diagram (positive logic)

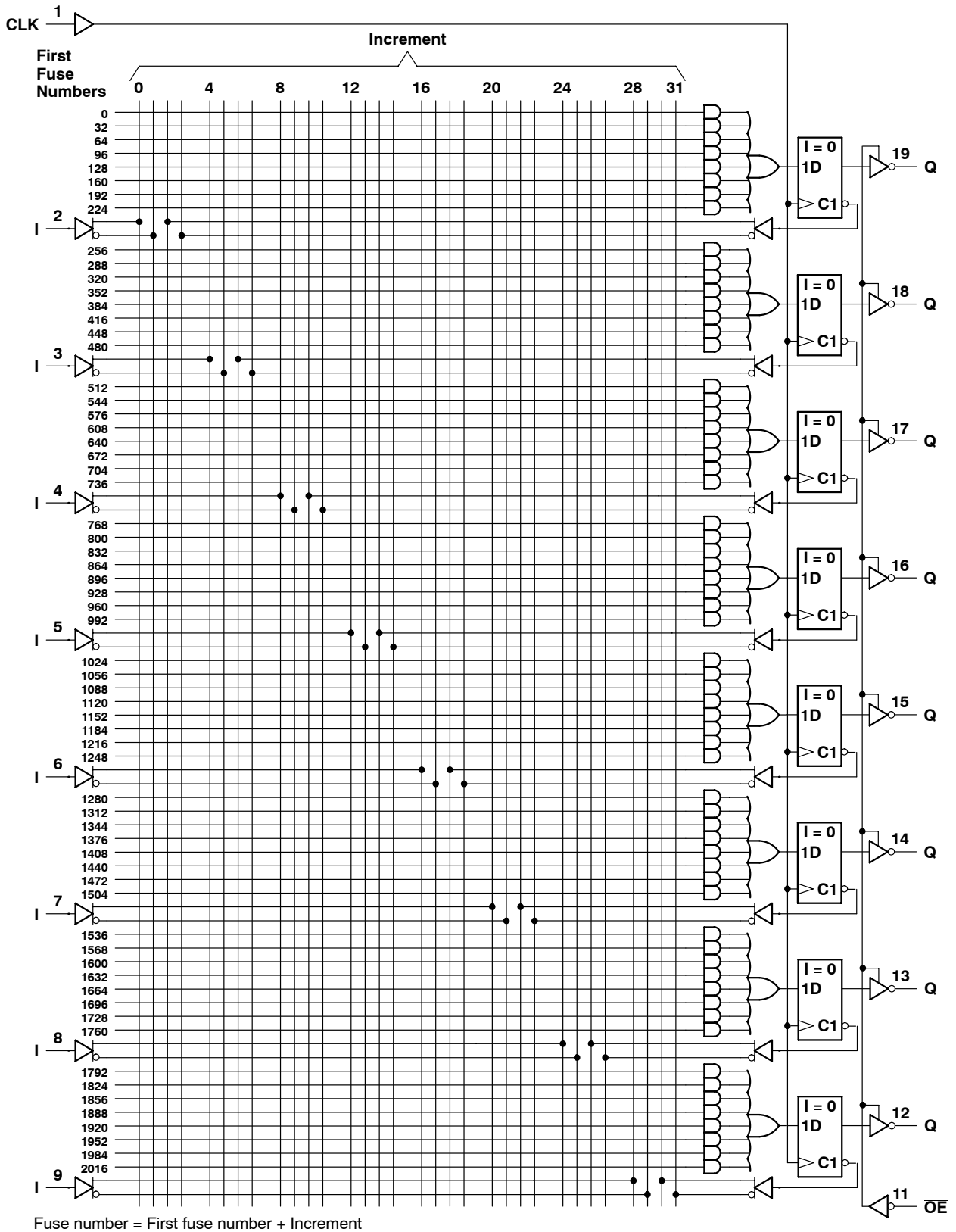

TIBPAL16L8-10C, TIBPAL16R4-10C, TIBPAL16R6-10C, TIBPAL16R8-10C HIGH-PERFORMANCE *IMPACT-X*™ PAL® CIRCUITS

SRPS017A – D3023, MAY 1987 – REVISED DECEMBER 2010

absolute maximum ratings over operating free-air temperature range (unless otherwise noted)

Supply voltage, V_{CC} (see Note 1)	7 V
Input voltage (see Note 1)	5.5 V
Voltage applied to disabled output (see Note 1)	5.5 V
Operating free-air temperature range	0°C to 75°C
Storage temperature range	-65°C to 150°C

NOTE 1: These ratings apply except for programming pins during a programming cycle.

recommended operating conditions

		MIN	NOM	MAX	UNIT
V_{CC}	Supply voltage	4.75	5	5.25	V
V_{IH}	High-level input voltage (see Note 2)	2		5.5	V
V_{IL}	Low-level input voltage (see Note 2)			0.8	V
I_{OH}	High-level output current			-3.2	mA
I_{OL}	Low-level output current			24	mA
f_{clock}	Clock frequency	0		62.5	MHz
t_w	Pulse duration, clock (see Note 2)	High		8	ns
		Low		8	
t_{su}	Setup time, input or feedback before clock↑	10			ns
t_h	Hold time, input or feedback after clock↑	0			ns
T_A	Operating free-air temperature	0	25	75	°C

NOTE 2: These are absolute voltage levels with respect to the ground pin of the device and include all overshoots due to system and/or tester noise. Testing these parameters should not be attempted without suitable equipment.

electrical characteristics over recommended operating free-air temperature range

PARAMETER	TEST CONDITIONS		MIN	TYP†	MAX	UNIT
V_{IK}	$V_{CC} = 4.75$ V,	$I_I = -18$ mA		-0.8	-1.5	V
V_{OH}	$V_{CC} = 4.75$ V,	$I_{OH} = -3.2$ mA	2.4	3.2		V
V_{OL}	$V_{CC} = 4.75$ V,	$I_{OL} = 24$ mA		0.3	0.5	V
I_{OZH}^\ddagger	$V_{CC} = 5.25$ V,	$V_O = 2.4$ V			100	μA
I_{OZL}^\ddagger	$V_{CC} = 5.25$ V,	$V_O = 0.4$ V			-100	μA
I_I	$V_{CC} = 5.25$ V,	$V_I = 5.5$ V			0.2	mA
I_{IH}^\ddagger	$V_{CC} = 5.25$ V,	$V_I = 2.4$ V			25	μA
I_{IL}^\ddagger	$V_{CC} = 5.25$ V,	$V_I = 0.4$ V		-0.08	-0.25	mA
I_{OS}^\S	$V_{CC} = 5.25$ V,	$V_O = 0$	-30	-70	-130	mA
I_{CC}	$V_{CC} = 5.25$ V,	$V_I = 0$, Outputs open		140	180	mA
C_i	$f = 1$ MHz,	$V_I = 2$ V		5		pF
C_o	$f = 1$ MHz,	$V_O = 2$ V		6		pF
$C_{i/o}$	$f = 1$ MHz,	$V_{I/O} = 2$ V		7.5		pF
C_{clk}	$f = 1$ MHz,	$V_{CLK} = 2$ V		6		pF

† All typical values are at $V_{CC} = 5$ V, $T_A = 25^\circ\text{C}$.‡ I/O leakage is the worst case of I_{OZL} and I_{IL} or I_{OZH} and I_{IH} respectively.

§ Not more than one output should be shorted at a time, and the duration of the short circuit should not exceed one second.

TIBPAL16L8-10C, TIBPAL16R4-10C, TIBPAL16R6-10C, TIBPAL16R8-10C HIGH-PERFORMANCE *IMPACT-X*™ *PAL*® CIRCUITS

SRPS017A – D3023, MAY 1987 – REVISED DECEMBER 2010

switching characteristics over recommended ranges of supply voltage and operating free-air temperature (unless otherwise noted)

PARAMETER	FROM (INPUT)	TO (OUTPUT)	TEST CONDITION	MIN	TYP†	MAX	UNIT
f _{max}	With feedback		R1 = 200 Ω, R2 = 390 Ω, See Figure 3	55.5	80		MHz
	Without feedback			62.5	85		
t _{pd}	I, I/O	O, I/O		3	7	10	ns
t _{pd}	CLK↑	Q		2	5	8	ns
t _{en}	OE↓	Q		1	4	10	ns
t _{dis}	OE↑	Q		1	4	10	ns
t _{en}	I, I/O	O, I/O		3	8	10	ns
t _{dis}	I, I/O	O, I/O		3	8	10	ns

† All typical values are at V_{CC} = 5 V, T_A = 25°C.

$$‡ f_{\max}(\text{with feedback}) = \frac{1}{t_{\text{su}} + t_{\text{pd}}(\text{CLK to Q})} \quad f_{\max}(\text{without feedback}) = \frac{1}{t_{\text{w high}} + t_{\text{w low}}}$$

TIBPAL16L8-12M, TIBPAL16R4-12M, TIBPAL16R6-12M, TIBPAL16R8-12M HIGH-PERFORMANCE *IMPACT-X*™ PAL® CIRCUITS

SRPS017D – D3023, MAY 1987 – REVISED DECEMBER 2010

absolute maximum ratings over operating free-air temperature range (unless otherwise noted)

Supply voltage, V_{CC} (see Note 1)	7 V
Input voltage (see Note 1)	5.5 V
Voltage applied to disabled output (see Note 1)	5.5 V
Operating free-air temperature range	-55°C to 125°C
Storage temperature range	-65°C to 150°C

NOTE 1: These ratings apply except for programming pins during a programming cycle.

recommended operating conditions

	MIN	NOM	MAX	UNIT
V_{CC} Supply voltage	4.5	5	5.5	V
V_{IH} High-level input voltage	2		5.5	V
V_{IL} Low-level input voltage			0.8	V
I_{OH} High-level output current			-2	mA
I_{OL} Low-level output current			12	mA
f_{clock}^{\dagger} Clock frequency	0		56	MHz
t_w Pulse duration, clock (see Note 2)	High		9	ns
	Low		9	
t_{su}^{\dagger} Setup time, input or feedback before clock \uparrow	11			ns
t_h^{\dagger} Hold time, input or feedback after clock \uparrow	0			ns
T_A Operating free-air temperature	-55	25	125	°C

NOTE 2: These are absolute voltage levels with respect to the ground pin of the device and include all overshoots due to system and/or tester noise. Testing these parameters should not be attempted without suitable equipment.

electrical characteristics over recommended operating free-air temperature range

PARAMETER	TEST CONDITIONS		MIN	TYP \dagger	MAX	UNIT
V_{IK}	$V_{CC} = 4.5$ V,	$I_I = -18$ mA		-0.8	-1.5	V
V_{OH}	$V_{CC} = 4.5$ V,	$I_{OH} = -2$ mA	2.4	3.2		V
V_{OL}	$V_{CC} = 4.5$ V,	$I_{OL} = 12$ mA		0.3	0.5	V
I_{OZH}^{\ddagger}	$V_{CC} = 5.5$ V,	$V_O = 2.4$ V			100	μ A
I_{OZL}^{\ddagger}	$V_{CC} = 5.5$ V,	$V_O = 0.4$ V			-100	μ A
I_I	$V_{CC} = 5.5$ V,	$V_I = 5.5$ V			0.2	mA
I_{IH}^{\ddagger}	$V_{CC} = 5.5$ V,	$V_I = 2.4$ V			25	μ A
I_{IL}^{\ddagger}	$V_{CC} = 5.5$ V,	$V_I = 0.4$ V		-0.08	-0.25	mA
I_{OS}^{\S}	$V_{CC} = 5.5$ V,	$V_O = 0.5$ V	-30	-70	-250	mA
I_{CC}	$V_{CC} = 5.5$ V,	$V_I = GND$, Outputs open		140	220	mA
C_i	$f = 1$ MHz,	$V_I = 2$ V		5		pF
C_o	$f = 1$ MHz,	$V_O = 2$ V		6		pF
$C_{i/o}$	$f = 1$ MHz,	$V_{I/O} = 2$ V		7.5		pF
C_{clk}	$f = 1$ MHz,	$V_{CLK} = 2$ V		6		pF

 \dagger All typical values are at $V_{CC} = 5$ V, $T_A = 25^\circ\text{C}$. \ddagger I/O leakage is the worst case of I_{OZL} and I_{IL} or I_{OZH} and I_{IH} respectively. \S Not more than one output should be shorted at a time, and the duration of the short circuit should not exceed one second. V_O is set at 0.5 V to avoid test problems caused by test equipment ground degradation.

TIBPAL16L8-12M, TIBPAL16R4-12M, TIBPAL16R6-12M, TIBPAL16R8-12M HIGH-PERFORMANCE *IMPACT-X*™ *PAL*® CIRCUITS

SRPS017D – D3023, MAY 1987 – REVISED DECEMBER 2010

switching characteristics over recommended ranges of supply voltage and operating free-air temperature (unless otherwise noted)

PARAMETER	FROM (INPUT)	TO (OUTPUT)	TEST CONDITION	MIN	TYP†	MAX	UNIT
f _{max}	With feedback		R1 = 390 Ω, R2 = 750 Ω, See Figure 3	48	80		MHz
	Without feedback			56	85		
t _{pd}	I, I/O	O, I/O		3	7	12	ns
t _{pd}	CLK↑	Q		2	5	10	ns
t _{en}	OE↓	Q		1	4	10	ns
t _{dis}	OE↑	Q		1	4	10	ns
t _{en}	I, I/O	O, I/O		3	8	14	ns
t _{dis}	I, I/O	O, I/O		2	8	12	ns

† All typical values are at V_{CC} = 5 V, T_A = 25°C.

$$‡ f_{\max}(\text{with feedback}) = \frac{1}{t_{\text{su}} + t_{\text{pd}}(\text{CLK to Q})}, \quad f_{\max}(\text{without feedback}) = \frac{1}{t_{\text{w high}} + t_{\text{w low}}}$$

TIBPAL16L8-10C, TIBPAL16R4-10C, TIBPAL16R6-10C, TIBPAL16R8-10C TIBPAL16L8-12M, TIBPAL16R4-12M, TIBPAL16R6-12M, TIBPAL16R8-12M HIGH-PERFORMANCE *IMPACT-X*™ PAL® CIRCUITS

SRPS017A – D3023, MAY 1987 – REVISED DECEMBER 2010

programming information

Texas Instruments programmable logic devices can be programmed using widely available software and inexpensive device programmers.

Complete programming specifications, algorithms, and the latest information on hardware, software, and firmware are available upon request. Information on programmers capable of programming Texas Instruments programmable logic is also available, upon request, from the nearest TI field sales office, local authorized TI distributor, or by calling Texas Instruments at (214) 997-5666.

preload procedure for registered outputs (see Figure 1 and Note 3)

The output registers can be preloaded to any desired state during device testing. This permits any state to be tested without having to step through the entire state-machine sequence. Each register is preloaded individually by following the steps given below.

- Step 1. With V_{CC} at 5 volts and Pin 1 at V_{IL} , raise Pin 11 to V_{IHH} .
- Step 2. Apply either V_{IL} or V_{IH} to the output corresponding to the register to be preloaded.
- Step 3. Pulse Pin 1, clocking in preload data.
- Step 4. Remove output voltage, then lower Pin 11 to V_{IL} . Preload can be verified by observing the voltage level at the output pin.

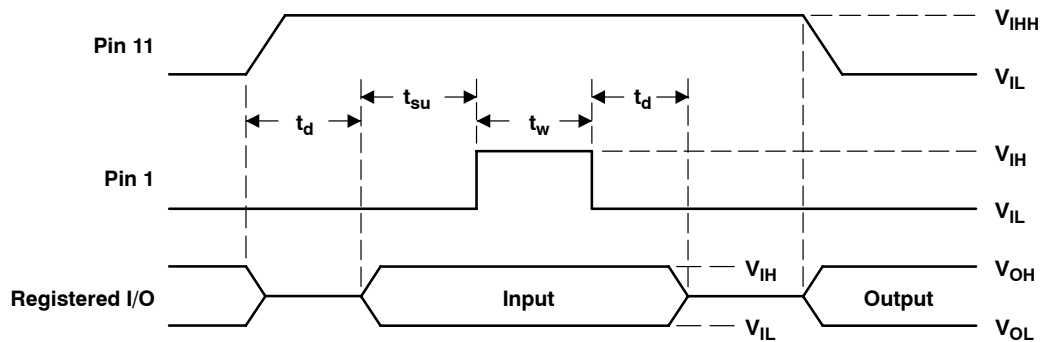

Figure 1. Preload Waveforms

NOTE 3: $t_d = t_{su} = t_h = 100 \text{ ns to } 1000 \text{ ns}$ $V_{IHH} = 10.25 \text{ V to } 10.75 \text{ v}$

TIBPAL16L8-10C, TIBPAL16R4-10C, TIBPAL16R6-10C, TIBPAL16R8-10C
TIBPAL16L8-12M, TIBPAL16R4-12M, TIBPAL16R6-12M, TIBPAL16R8-12M
HIGH-PERFORMANCE *IMPACT-X*™ PAL® CIRCUITS

SRPS017A – D3023, MAY 1987 – REVISED DECEMBER

power-up reset (see Figure 2)

Following power up, all registers are reset to zero. This feature provides extra flexibility to the system designer and is especially valuable in simplifying state-machine initialization. To ensure a valid power-up reset, it is important that the rise of V_{CC} be monotonic. Following power-up reset, a low-to-high clock transition must not occur until all applicable input and feedback setup times are met.

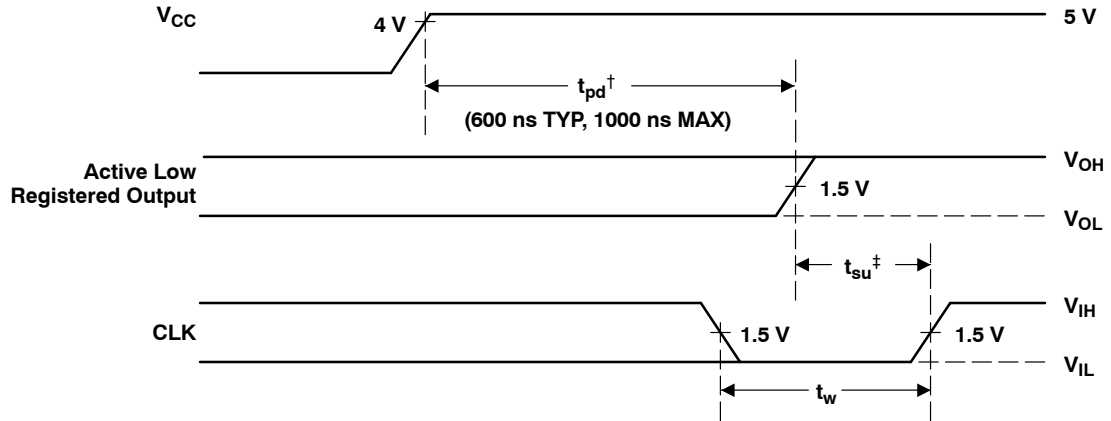

† This is the power-up reset time and applies to registered outputs only. The values shown are from characterization data.

‡ This is the setup time for input or feedback.

Figure 2. Power-Up Reset Waveforms

TIBPAL16L8-10C, TIBPAL16R4-10C, TIBPAL16R6-10C, TIBPAL16R8-10C TIBPAL16L8-12M, TIBPAL16R4-12M, TIBPAL16R6-12M, TIBPAL16R8-12M HIGH-PERFORMANCE *IMPACT-X*™ PAL® CIRCUITS

SRPS017A – D3023, MAY 1987 – REVISED DECEMBER 2010

PARAMETER MEASUREMENT INFORMATION

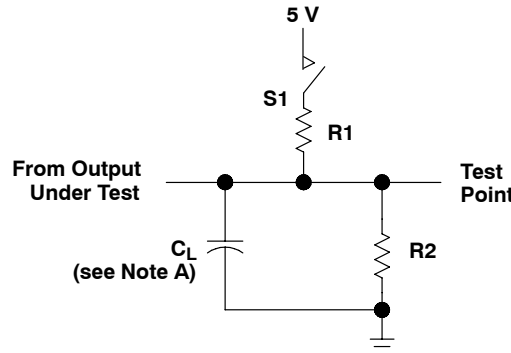

LOAD CIRCUIT FOR 3-STATE OUTPUTS

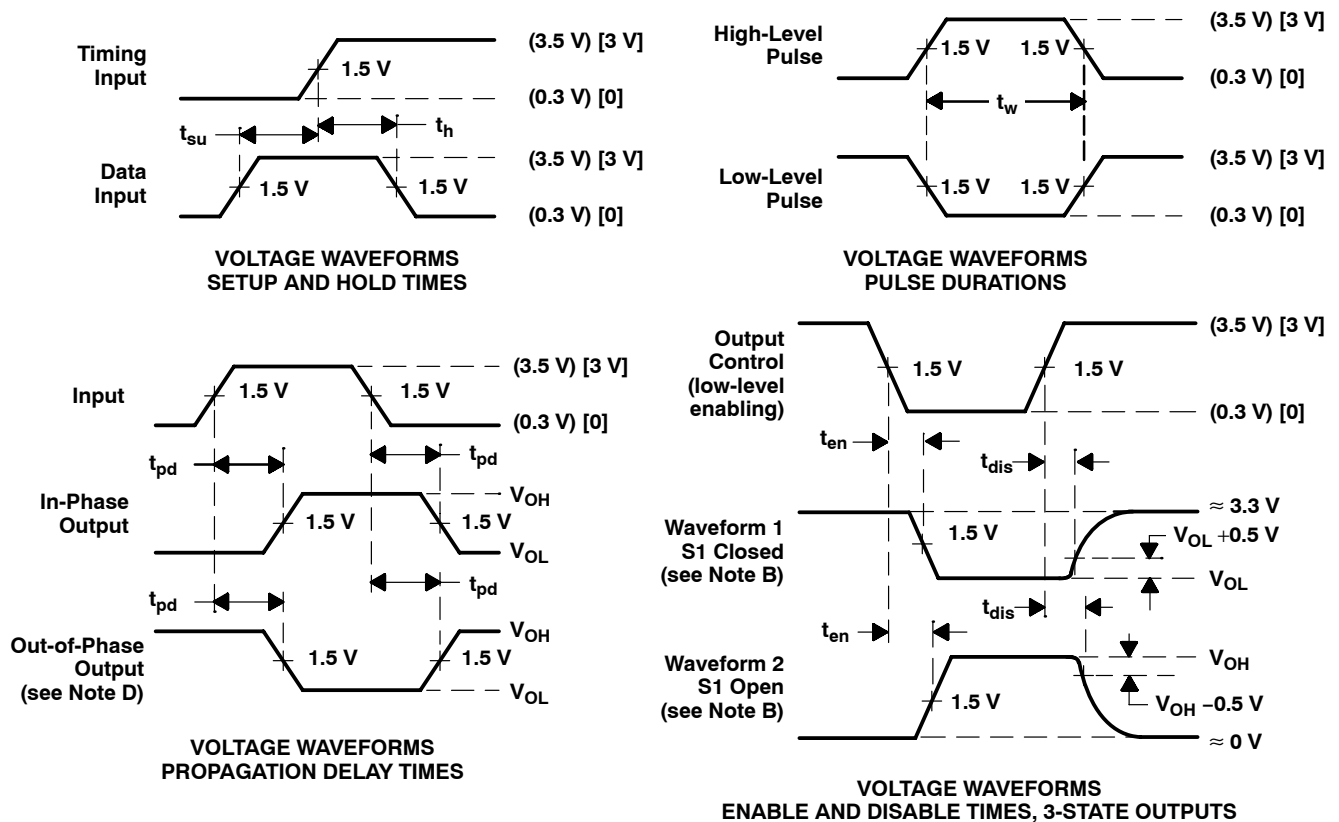

- NOTES: A. C_L includes probe and jig capacitance and is 50 pF for t_{pd} and t_{en} , 5 pF for t_{dis} .
 B. Waveform 1 is for an output with internal conditions such that the output is low except when disabled by the output control. Waveform 2 is for an output with internal conditions such that the output is high except when disabled by the output control.
 C. All input pulses have the following characteristics: For C suffix, use the voltage levels indicated in parentheses (), $PRR \leq 1$ MHz, $t_r = t_f = 2$ ns, duty cycle = 50%; For M suffix, use the voltage levels indicated in brackets [], $PRR \leq 10$ MHz, t_r and $t_f \leq 2$ ns, duty cycle = 50%.
 D. When measuring propagation delay times of 3-state outputs, switch S1 is closed.
 E. Equivalent loads may be used for testing.

Figure 3. Load Circuit and Voltage Waveforms

TIBPAL16R4-10C, TIBPAL16R6-10C, TIBPAL16R8-10C HIGH-PERFORMANCE *IMPACT-X*™ PAL® CIRCUITS

SRPS017 – D3023, MAY 1987 – REVISED DECEMBER 2010

metastable characteristics of TIBPAL16R4-10C, TIBPAL16R6-10C, and TIBPAL16R8-10C

At some point a system designer is faced with the problem of synchronizing two digital signals operating at two different frequencies. This problem is typically overcome by synchronizing one of the signals to the local clock through use of a flip-flop. However, this solution presents an awkward dilemma since the setup and hold time specifications associated with the flip-flop are sure to be violated. The metastable characteristics of the flip-flop can influence overall system reliability.

Whenever the setup and hold times of a flip-flop are violated, its output response becomes uncertain and is said to be in the metastable state if the output hangs up in the region between V_{IL} and V_{IH} . This metastable condition lasts until the flip-flop falls into one of its two stable states, which takes longer than the specified maximum propagation delay time (CLK to Q max).

From a system engineering standpoint, a designer cannot use the specified data sheet maximum for propagation delay time when using the flip-flop as a data synchronizer – how long to wait after the specified data sheet maximum must be known before using the data in order to guarantee reliable system operation.

The circuit shown in Figure 4 can be used to evaluate MTBF (Mean Time Between Failure) and Δt for a selected flip-flop. Whenever the Q output of the DUT is between 0.8 V and 2 V, the comparators are in opposite states. When the Q output of the DUT is higher than 2 V or lower than 0.8 V, the comparators are at the same logic level. The outputs of the two comparators are sampled a selected time (Δt) after SCLK. The exclusive OR gate detects the occurrence of a failure and increments the failure counter.

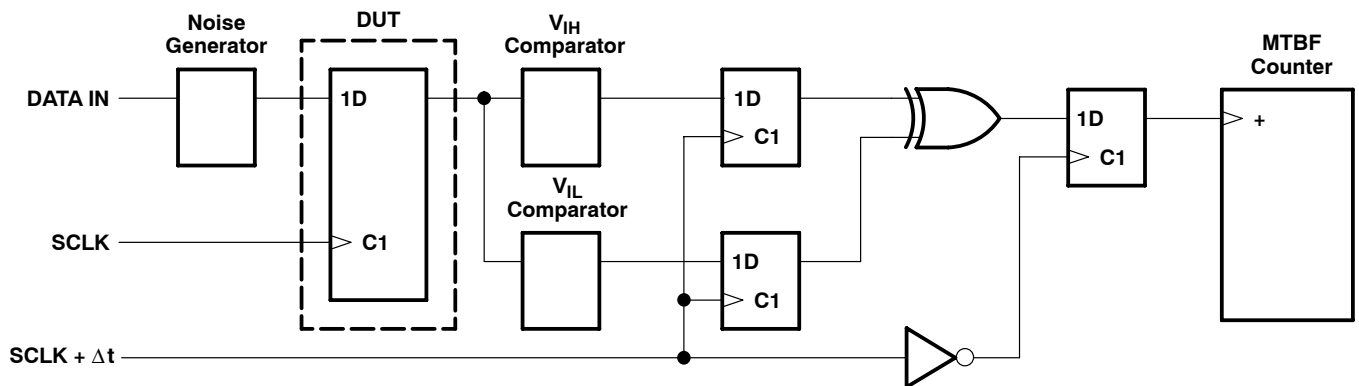

Figure 4. Metastable Evaluation Test Circuit

In order to maximize the possibility of forcing the DUT into a metastable state, the input data signal is applied so that it always violates the setup and hold time. This condition is illustrated in the timing diagram in Figure 5. Any other relationship of SCLK to data will provide less chance for the device to enter into the metastable state.

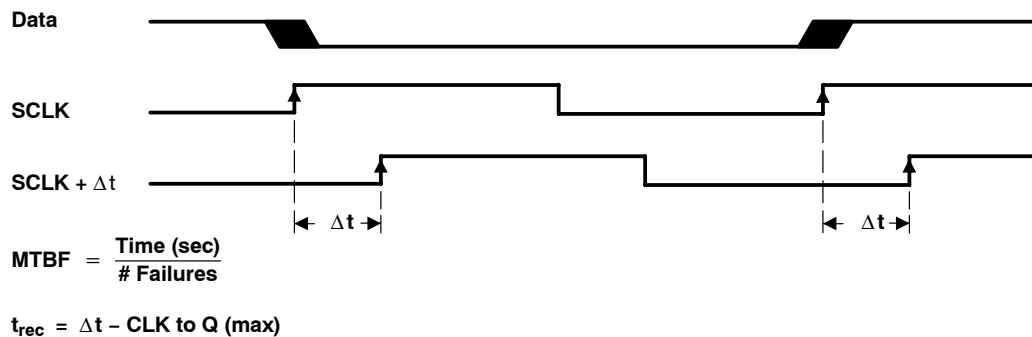

Figure 5. Timing Diagram

TIBPAL16R4-10C, TIBPAL16R6-10C, TIBPAL16R8-10C HIGH-PERFORMANCE *IMPACT-X*™ PAL® CIRCUITS

SRPS017A – D3023, MAY 1987 – REVISED DECEMBER 2010

By using the described test circuit, MTBF can be determined for several different values of Δt (see Figure 4). Plotting this information on semilog scale demonstrates the metastable characteristics of the selected flip-flop. Figure 6 shows the results for the TIBPAL16'-10C operating at 1 MHz.

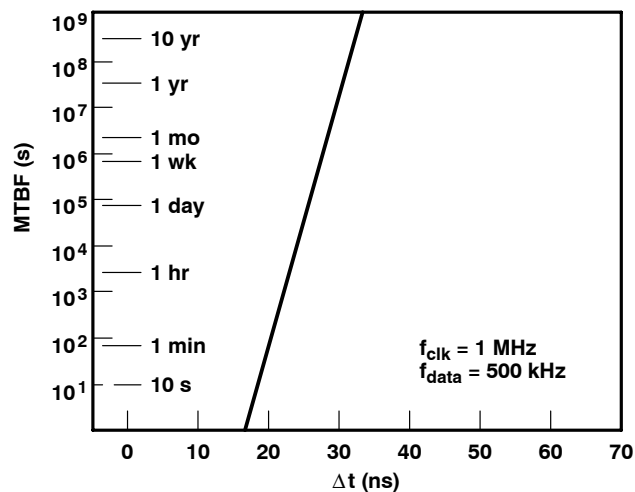

Figure 6. Metastable Characteristics

From the data taken in the above experiment, an equation can be derived for the metastable characteristics at other clock frequencies.

The metastable equation: $\frac{1}{\text{MTBF}} = f_{\text{SCLK}} \times f_{\text{data}} \times C1 e^{-C2 \times \Delta t}$

The constants C1 and C2 describe the metastable characteristics of the device. From the experimental data, these constants can be solved for: $C1 = 9.15 \times 10^{-7}$ and $C2 = 0.959$

Therefore

$$\frac{1}{\text{MTBF}} = f_{\text{SCLK}} \times f_{\text{data}} \times 9.15 \times 10^{-7} e^{-0.959 \times \Delta t}$$

definition of variables

DUT (Device Under Test): The DUT is a 10-ns registered PLD programmed with the equation $Q = D$.

MTBF (Mean Time Between Failures): The average time (s) between metastable occurrences that cause a violation of the device specifications.

f_{SCLK} (system clock frequency): Actual clock frequency for the DUT.

f_{data} (data frequency): Actual data frequency for a specified input to the DUT.

C1: Calculated constant that defines the magnitude of the curve.

C2: Calculated constant that defines the slope of the curve.

t_{rec} (metastability recovery time): Minimum time required to guarantee recovery from metastability, at a given MTBF failure rate. $t_{\text{rec}} = \Delta t - t_{\text{pd}}$ (CLK to Q, max)

Δt : The time difference (ns) from when the synchronizing flip-flop is clocked to when its output is sampled.

The test described above has shown the metastable characteristics of the TIBPAL16R4/R6/R8-10C series. For additional information on metastable characteristics of Texas Instruments logic circuits, please refer to TI Applications publication SDAA004, "Metastable Characteristics, Design Considerations for ALS, AS, and LS Circuits."

**TIBPAL16L8-10C, TIBPAL16R4-10C, TIBPAL16R6-10C, TIBPAL16R8-10C
TIBPAL16L8-12M, TIBPAL16R4-12M, TIBPAL16R6-12M, TIBPAL16R8-12M
HIGH-PERFORMANCE *IMPACT-X*™ PAL® CIRCUITS**

SRPS017A – D3023, MAY 1987 – REVISED DECEMBER 2010

TYPICAL CHARACTERISTICS

**PROPAGATION DELAY TIME
vs
FREE-AIR TEMPERATURE**

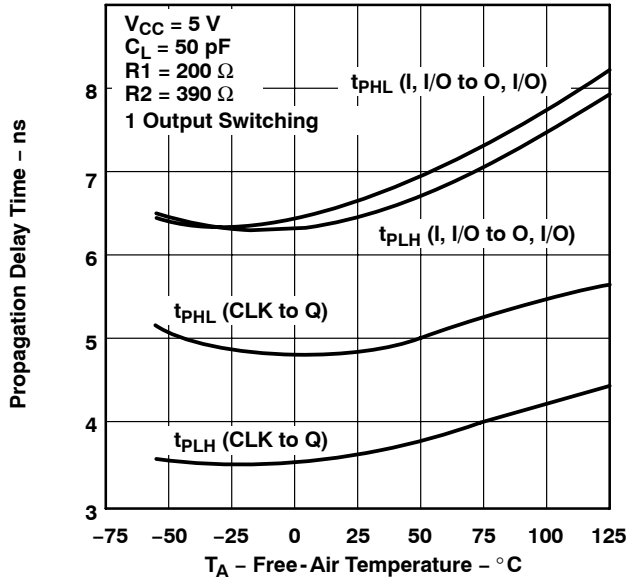

Figure 7

**PROPAGATION DELAY TIME
vs
SUPPLY VOLTAGE**

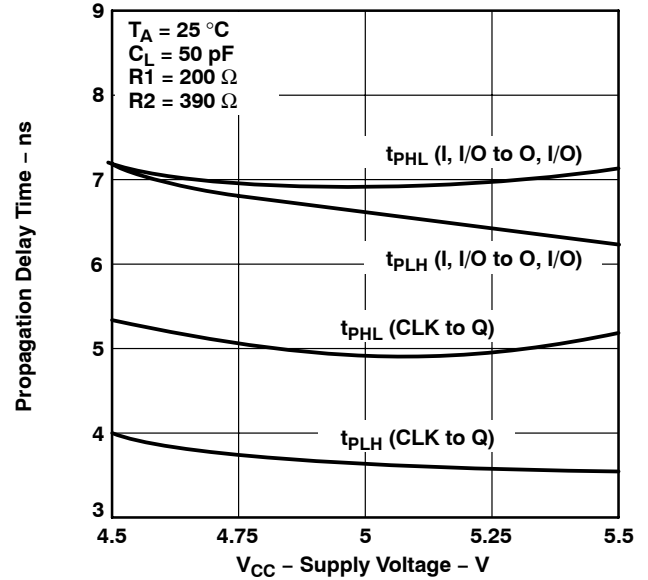

Figure 8

**PROPAGATION DELAY TIME
vs
NUMBER OF OUTPUTS SWITCHING**

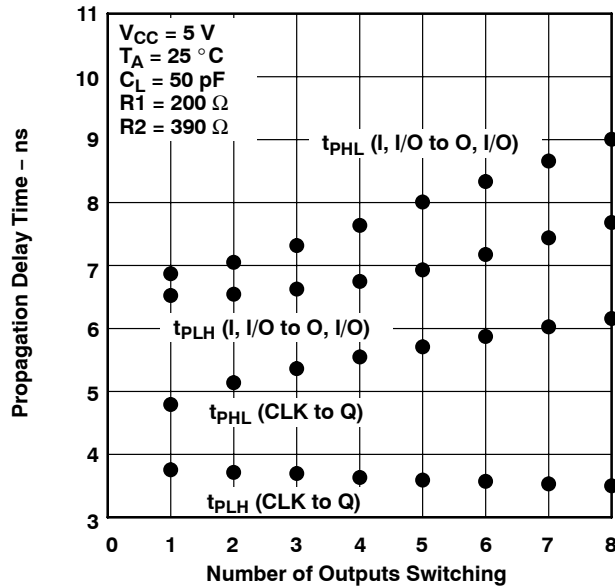

Figure 9

TIBPAL16L8-10C, TIBPAL16R4-10C, TIBPAL16R6-10C, TIBPAL16R8-10C TIBPAL16L8-12M, TIBPAL16R4-12M, TIBPAL16R6-12M, TIBPAL16R8-12M HIGH-PERFORMANCE *IMPACT-X*™ PAL® CIRCUITS

SRPS017A - D3023, MAY 1987 - REVISED DECEMBER 2010

TYPICAL CHARACTERISTICS

PROPAGATION DELAY TIME
vs
LOAD CAPACITANCE

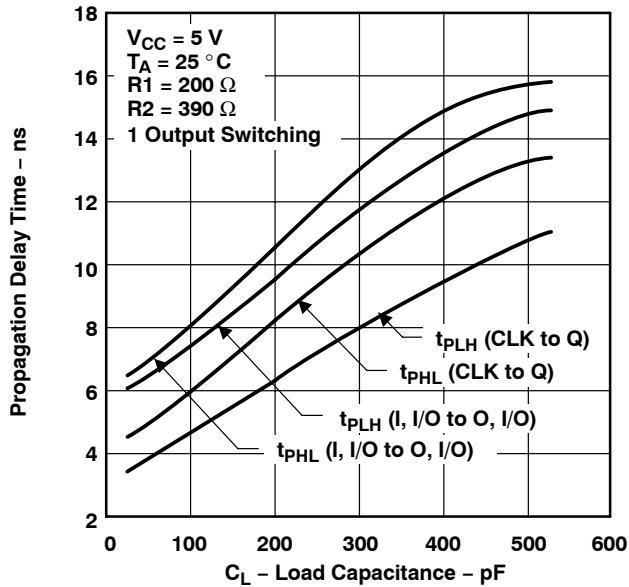

Figure 10

POWER DISSIPATION
vs
FREQUENCY
8-BIT COUNTER MODE

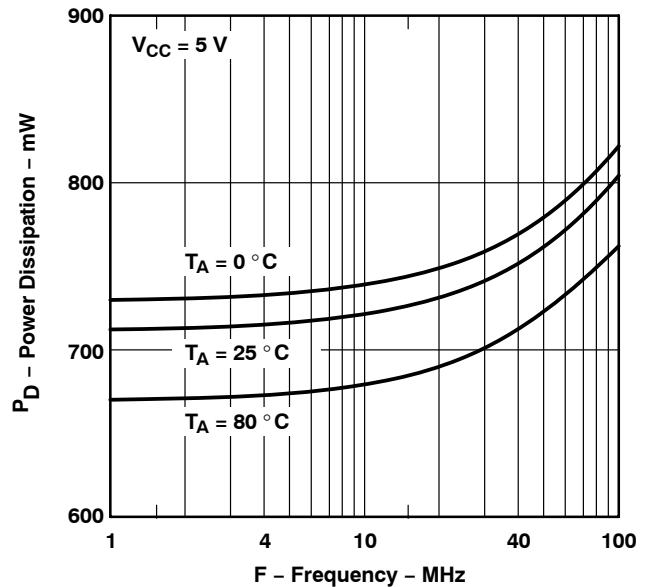

Figure 11

SUPPLY CURRENT
vs
FREE-AIR TEMPERATURE

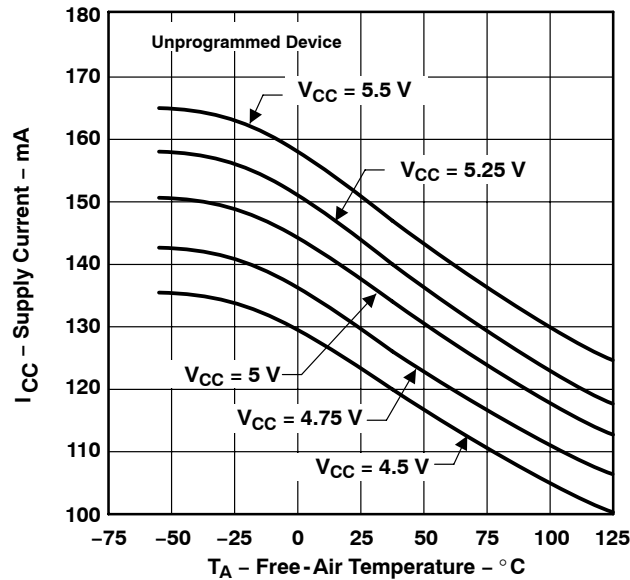

Figure 12

TI North American Sales Offices

ALABAMA: Huntsville: (205) 837-7530
ARIZONA: Phoenix: (602) 995-1007
CALIFORNIA: Irvine: (714) 660-1200
 San Diego: (619) 278-9600
 Santa Clara: (408) 980-9000
 Woodland Hills: (818) 704-8100
COLORADO: Aurora: (303) 368-8000
CONNECTICUT: Wallingford: (203) 269-0074
FLORIDA: Altamonte Springs: (407) 260-2116
 Fort Lauderdale: (305) 973-8502
 Tampa: (813) 885-7588
GEORGIA: Norcross: (404) 662-7967
ILLINOIS: Arlington Heights: (708) 640-3000
INDIANA: Carmel: (317) 573-6400
 Fort Wayne: (219) 489-4697
KANSAS: Overland Park: (913) 451-4511
MARYLAND: Columbia: (410) 964-2003
MASSACHUSETTS: Waltham: (617) 895-9100
MICHIGAN: Farmington Hills: (313) 553-1581
MINNESOTA: Eden Prairie: (612) 828-9300
MISSOURI: St. Louis: (314) 821-8400
NEW JERSEY: Iselin: (908) 750-1050
NEW MEXICO: Albuquerque: (505) 345-2555
NEW YORK: East Syracuse: (315) 463-9291
 Fishkill: (914) 897-2900
 Melville: (516) 454-6600
 Pittsford: (716) 385-6770
NORTH CAROLINA: Charlotte: (704) 527-0930
 Raleigh: (919) 876-2725
OHIO: Beachwood: (216) 765-7258
 Beavercreek: (513) 427-6200
OREGON: Beaverton: (503) 643-6758
PENNSYLVANIA: Blue Bell: (215) 825-9500
PUERTO RICO: Hato Rey: (809) 753-8700
TEXAS: Austin: (512) 250-6769
 Dallas: (214) 917-1264
 Houston: (713) 778-6592
 Midland: (915) 561-7137
UTAH: Salt Lake City: (801) 466-8972
WISCONSIN: Waukesha: (414) 798-1001
CANADA: Nepean: (613) 726-1970
 Richmond Hill: (416) 884-9181
 St. Laurent: (514) 335-8392

TI Regional Technology Centers

CALIFORNIA: Irvine: (714) 660-8140
 Santa Clara: (408) 748-2222
GEORGIA: Norcross: (404) 662-7945
ILLINOIS: Arlington Heights: (708) 640-2909
INDIANA: Indianapolis: (317) 573-6400
MASSACHUSETTS: Waltham: (617) 895-9196
MEXICO: Mexico City: 491-70834
MINNESOTA: Minneapolis: (612) 828-9300
TEXAS: Dallas: (214) 917-3881
CANADA: Nepean: (613) 726-1970

Customer Response Center

TOLL FREE: (800) 336-5236
OUTSIDE USA: (214) 995-6611
 (8:00 a.m. – 5:00 p.m. CST)

TI Authorized North American Distributors

Alliance Electronics, Inc. (military product only)
 Almac/Arrow
 Anthem Electronics
 Arrow/Schweber
 Future Electronics (Canada)
 GRS Electronics Co., Inc.
 Hall-Mark Electronics
 Marshall Industries
 Newark Electronics
 Rochester Electronics, Inc.
 (obsolete product only) (508) 462-9332
 Wyle Laboratories
 Zeus Components

TI Distributors

ALABAMA: Arrow/Schweber (205) 837-6955; Hall-Mark (205) 837-8700; Marshall (205) 881-9235.
ARIZONA: Anthem (602) 966-6600; Arrow/Schweber (602) 437-0750; Hall-Mark (602) 431-0030; Marshall (602) 496-0290; Wyle (602) 437-2088.
CALIFORNIA: Los Angeles/Orange County: Anthem (818) 775-1333, (714) 768-4444; Arrow/Schweber (818) 380-9686, (714) 838-5422; Hall-Mark (818) 773-4500, (714) 727-6000; Marshall (818) 878-7000, (714) 458-5301; Wyle (818) 880-9000, (714) 863-9953; Zeus (714) 921-9000, (818) 889-3838;
Sacramento: Anthem (916) 624-9744; Hall-Mark (916) 624-9781; Marshall (916) 635-9700; Wyle (916) 638-5282;
San Diego: Anthem (619) 453-9005; Arrow/Schweber (619) 565-4800; Hall-Mark (619) 268-1201; Marshall (619) 578-9600; Wyle (619) 565-9171; Zeus (619) 277-9681.
San Francisco Bay Area: Anthem (408) 453-1200; Arrow/Schweber (408) 441-9700, (510) 430-9477; Hall-Mark (408) 432-4000; Marshall (408) 942-4600; Wyle (408) 727-2500; Zeus (408) 629-4789.
COLORADO: Anthem (303) 790-4500; Arrow/Schweber (303) 799-0258; Hall-Mark (303) 790-1662; Marshall (303) 451-8383; Wyle (303) 457-9953.
CONNECTICUT: Anthem (203) 575-1575; Arrow/Schweber (203) 265-7741; Hall-Mark (203) 271-2844; Marshall (203) 265-3822.
FLORIDA: Fort Lauderdale: Arrow/Schweber (305) 429-8200; Hall-Mark (305) 971-9280; Marshall (305) 977-4880.
Orlando: Arrow/Schweber (407) 333-9300; Hall-Mark (407) 830-5855; Marshall (407) 767-8585; Zeus (407) 788-9100.
Tampa: Hall-Mark (813) 541-7440; Marshall (813) 573-1399.
GEORGIA: Arrow/Schweber (404) 497-1300; Hall-Mark (404) 623-4400; Marshall (404) 923-5750.
ILLINOIS: Anthem (708) 884-0200; Arrow/Schweber (708) 250-0500; Hall-Mark (312) 860-3800; Marshall (708) 490-0155; Newark (312) 784-5100.
INDIANA: Arrow/Schweber (317) 299-2071; Hall-Mark (317) 872-8875; Marshall (317) 297-0483.
IOWA: Arrow/Schweber (319) 395-7230.
KANSAS: Arrow/Schweber (913) 541-9542; Hall-Mark (913) 888-4747; Marshall (913) 492-3121.
MARYLAND: Anthem (301) 995-6640; Arrow/Schweber (301) 596-7800; Hall-Mark (301) 988-9800; Marshall (301) 622-1118; Zeus (301) 997-1118.
MASSACHUSETTS: Anthem (508) 657-5170; Arrow/Schweber (508) 658-0900; Hall-Mark (508) 667-0902; Marshall (508) 658-0810; Wyle (617) 272-7300; Zeus (617) 246-8200.

MICHIGAN: Detroit: Arrow/Schweber (313) 462-2290; Hall-Mark (313) 416-5800; Marshall (313) 525-5850; Newark (313) 967-0600.
MINNESOTA: Anthem (612) 944-5454; Arrow/Schweber (612) 941-5280; Hall-Mark (612) 881-2600; Marshall (612) 559-2211.
MISSOURI: Arrow/Schweber (314) 567-6888; Hall-Mark (314) 291-5350; Marshall (314) 291-4650.
NEW JERSEY: Anthem (201) 227-7960; Arrow/Schweber (201) 227-7880, (609) 596-8000; Hall-Mark (201) 515-3000, (609) 235-1900; Marshall (201) 882-0320, (609) 234-9100.
NEW MEXICO: Alliance (505) 292-3360.
NEW YORK: Long Island: Anthem (516) 864-6600; Arrow/Schweber (516) 231-1000; Hall-Mark (516) 737-0600; Marshall (516) 273-2424; Zeus (914) 937-7400.
Rochester: Arrow/Schweber (716) 427-0300; Hall-Mark (716) 425-3300; Marshall (716) 235-7620.
Syracuse: Marshall (607) 785-2345.
NORTH CAROLINA: Arrow/Schweber (919) 876-3132; Hall-Mark (919) 872-0712; Marshall (919) 878-9882.
OHIO: Cleveland: Arrow/Schweber (216) 248-3990; Hall-Mark (216) 349-4632; Marshall (216) 248-1788.
Columbus: Hall-Mark (614) 888-3313.
Dayton: Arrow/Schweber (513) 435-5563; Marshall (513) 898-4480; Zeus (513) 293-6162.
OKLAHOMA: Arrow/Schweber (918) 252-7537; Hall-Mark (918) 254-6110.
OREGON: Almac/Arrow (503) 629-8090; Anthem (503) 643-1114; Marshall (503) 644-5050; Wyle (503) 643-7900.
PENNSYLVANIA: Anthem (215) 443-5150; Arrow/Schweber (215) 928-1800; GRS (215) 922-7037; (609) 964-8560; Marshall (412) 788-0441.
TEXAS: Austin: Arrow/Schweber (512) 835-4180; Hall-Mark (512) 258-8848; Marshall (512) 837-1991; Wyle (512) 345-8853;
Dallas: Anthem (214) 238-7100; Arrow/Schweber (214) 380-6464; Hall-Mark (214) 553-4300; Marshall (214) 233-5200; Wyle (214) 235-9953; Zeus (214) 783-7010;
Houston: Arrow/Schweber (713) 530-4700; Hall-Mark (713) 781-6100; Marshall (713) 467-1666; Wyle (713) 879-9953.
UTAH: Anthem (801) 973-8555; Arrow/Schweber (801) 973-6913; Marshall (801) 973-2288; Wyle (801) 974-9953.
WASHINGTON: Almac/Arrow (206) 643-9992; Anthem (206) 483-1700; Marshall (206) 486-5747; Wyle (206) 881-1150.
WISCONSIN: Arrow/Schweber (414) 792-0150; Hall-Mark (414) 797-7844; Marshall (414) 797-8400.
CANADA: Calgary: Future (403) 235-5325;
Edmonton: Future (403) 438-2858;
Montreal: Arrow/Schweber (514) 421-7411; Future (514) 694-7710; Marshall (514) 694-8142
Ottawa: Arrow/Schweber (613) 226-6903; Future (613) 820-8313.
Quebec: Future (418) 897-6666.
Toronto: Arrow/Schweber (416) 670-7769; Future (416) 612-9200; Marshall (416) 458-8046.
Vancouver: Arrow/Schweber (604) 421-2333; Future (604) 294-1166.

TI Die Processors

Chip Supply (407) 298-7100
 Elmo Semiconductor (818) 768-7400
 Minco Technology Labs (512) 834-2022



PACKAGING INFORMATION

Orderable part number	Status (1)	Material type (2)	Package Pins	Package qty Carrier	RoHS (3)	Lead finish/ Ball material (4)	MSL rating/ Peak reflow (5)	Op temp (°C)	Part marking (6)
5962-85155152A	NRND	Production	LCCC (FK) 20	55 TUBE	No	SNPB	N/A for Pkg Type	-55 to 125	5962- 85155152A TIBPAL16 R6-12MFKB
5962-8515515RA	NRND	Production	CDIP (J) 20	20 TUBE	No	SNPB	N/A for Pkg Type	-55 to 125	5962-8515515RA TIBPAL16R6-12M JB
5962-85155162A	NRND	Production	LCCC (FK) 20	55 TUBE	No	SNPB	N/A for Pkg Type	-55 to 125	5962- 85155162A TIBPAL16 R4-12MFKB
5962-8515516RA	NRND	Production	CDIP (J) 20	20 TUBE	No	SNPB	N/A for Pkg Type	-55 to 125	5962-8515516RA TIBPAL16R4-12M JB
TIBPAL16R4-12MFKB	NRND	Production	LCCC (FK) 20	55 TUBE	No	SNPB	N/A for Pkg Type	-55 to 125	5962- 85155162A TIBPAL16 R4-12MFKB
TIBPAL16R4-12MFKB.A	NRND	Production	LCCC (FK) 20	55 TUBE	No	SNPB	N/A for Pkg Type	-55 to 125	5962- 85155162A TIBPAL16 R4-12MFKB
TIBPAL16R4-12MJ	NRND	Production	CDIP (J) 20	20 TUBE	No	SNPB	N/A for Pkg Type	-55 to 125	TIBPAL16R4-12M J
TIBPAL16R4-12MJ.A	NRND	Production	CDIP (J) 20	20 TUBE	No	SNPB	N/A for Pkg Type	-55 to 125	TIBPAL16R4-12M J
TIBPAL16R4-12MJB	NRND	Production	CDIP (J) 20	20 TUBE	No	SNPB	N/A for Pkg Type	-55 to 125	5962-8515516RA TIBPAL16R4-12M JB
TIBPAL16R4-12MJB.A	NRND	Production	CDIP (J) 20	20 TUBE	No	SNPB	N/A for Pkg Type	-55 to 125	5962-8515516RA TIBPAL16R4-12M JB
TIBPAL16R6-12MFKB	NRND	Production	LCCC (FK) 20	55 TUBE	No	SNPB	N/A for Pkg Type	-55 to 125	5962- 85155152A TIBPAL16 R6-12MFKB

Orderable part number	Status (1)	Material type (2)	Package Pins	Package qty Carrier	RoHS (3)	Lead finish/ Ball material (4)	MSL rating/ Peak reflow (5)	Op temp (°C)	Part marking (6)
TIBPAL16R6-12MFKB.A	NRND	Production	LCCC (FK) 20	55 TUBE	No	SNPB	N/A for Pkg Type	-55 to 125	5962- 85155152A TIBPAL16 R6-12MFKB
TIBPAL16R6-12MJB	NRND	Production	CDIP (J) 20	20 TUBE	No	SNPB	N/A for Pkg Type	-55 to 125	5962-8515515RA TIBPAL16R6-12M JB
TIBPAL16R6-12MJB.A	NRND	Production	CDIP (J) 20	20 TUBE	No	SNPB	N/A for Pkg Type	-55 to 125	5962-8515515RA TIBPAL16R6-12M JB

(1) **Status:** For more details on status, see our [product life cycle](#).

(2) **Material type:** When designated, preproduction parts are prototypes/experimental devices, and are not yet approved or released for full production. Testing and final process, including without limitation quality assurance, reliability performance testing, and/or process qualification, may not yet be complete, and this item is subject to further changes or possible discontinuation. If available for ordering, purchases will be subject to an additional waiver at checkout, and are intended for early internal evaluation purposes only. These items are sold without warranties of any kind.

(3) **RoHS values:** Yes, No, RoHS Exempt. See the [TI RoHS Statement](#) for additional information and value definition.

(4) **Lead finish/Ball material:** Parts may have multiple material finish options. Finish options are separated by a vertical ruled line. Lead finish/Ball material values may wrap to two lines if the finish value exceeds the maximum column width.

(5) **MSL rating/Peak reflow:** The moisture sensitivity level ratings and peak solder (reflow) temperatures. In the event that a part has multiple moisture sensitivity ratings, only the lowest level per JEDEC standards is shown. Refer to the shipping label for the actual reflow temperature that will be used to mount the part to the printed circuit board.

(6) **Part marking:** There may be an additional marking, which relates to the logo, the lot trace code information, or the environmental category of the part.

Multiple part markings will be inside parentheses. Only one part marking contained in parentheses and separated by a "~" will appear on a part. If a line is indented then it is a continuation of the previous line and the two combined represent the entire part marking for that device.

Important Information and Disclaimer: The information provided on this page represents TI's knowledge and belief as of the date that it is provided. TI bases its knowledge and belief on information provided by third parties, and makes no representation or warranty as to the accuracy of such information. Efforts are underway to better integrate information from third parties. TI has taken and continues to take reasonable steps to provide representative and accurate information but may not have conducted destructive testing or chemical analysis on incoming materials and chemicals. TI and TI suppliers consider certain information to be proprietary, and thus CAS numbers and other limited information may not be available for release.

In no event shall TI's liability arising out of such information exceed the total purchase price of the TI part(s) at issue in this document sold by TI to Customer on an annual basis.

TUBE

*All dimensions are nominal

Device	Package Name	Package Type	Pins	SPQ	L (mm)	W (mm)	T (μm)	B (mm)
5962-85155152A	FK	LCCC	20	55	506.98	12.06	2030	NA
5962-85155162A	FK	LCCC	20	55	506.98	12.06	2030	NA
TIBPAL16R4-12MFKB	FK	LCCC	20	55	506.98	12.06	2030	NA
TIBPAL16R4-12MFKB.A	FK	LCCC	20	55	506.98	12.06	2030	NA
TIBPAL16R6-12MFKB	FK	LCCC	20	55	506.98	12.06	2030	NA
TIBPAL16R6-12MFKB.A	FK	LCCC	20	55	506.98	12.06	2030	NA

J (R-GDIP-T**)

14 LEADS SHOWN

CERAMIC DUAL IN-LINE PACKAGE



DIM \ PINS **	14	16	18	20
A	0.300 (7,62) BSC	0.300 (7,62) BSC	0.300 (7,62) BSC	0.300 (7,62) BSC
B MAX	0.785 (19,94)	.840 (21,34)	0.960 (24,38)	1.060 (26,92)
B MIN	—	—	—	—
C MAX	0.300 (7,62)	0.300 (7,62)	0.310 (7,87)	0.300 (7,62)
C MIN	0.245 (6,22)	0.245 (6,22)	0.220 (5,59)	0.245 (6,22)



4040083/F 03/03

- NOTES:
- All linear dimensions are in inches (millimeters).
 - This drawing is subject to change without notice.
 - This package is hermetically sealed with a ceramic lid using glass frit.
 - Index point is provided on cap for terminal identification only on press ceramic glass frit seal only.
 - Falls within MIL STD 1835 GDIP1-T14, GDIP1-T16, GDIP1-T18 and GDIP1-T20.

GENERIC PACKAGE VIEW

FK 20

LCCC - 2.03 mm max height

8.89 x 8.89, 1.27 mm pitch

LEADLESS CERAMIC CHIP CARRIER

This image is a representation of the package family, actual package may vary.
Refer to the product data sheet for package details.



4229370VA\

IMPORTANT NOTICE AND DISCLAIMER

TI PROVIDES TECHNICAL AND RELIABILITY DATA (INCLUDING DATASHEETS), DESIGN RESOURCES (INCLUDING REFERENCE DESIGNS), APPLICATION OR OTHER DESIGN ADVICE, WEB TOOLS, SAFETY INFORMATION, AND OTHER RESOURCES "AS IS" AND WITH ALL FAULTS, AND DISCLAIMS ALL WARRANTIES, EXPRESS AND IMPLIED, INCLUDING WITHOUT LIMITATION ANY IMPLIED WARRANTIES OF MERCHANTABILITY, FITNESS FOR A PARTICULAR PURPOSE OR NON-INFRINGEMENT OF THIRD PARTY INTELLECTUAL PROPERTY RIGHTS.

These resources are intended for skilled developers designing with TI products. You are solely responsible for (1) selecting the appropriate TI products for your application, (2) designing, validating and testing your application, and (3) ensuring your application meets applicable standards, and any other safety, security, regulatory or other requirements.

These resources are subject to change without notice. TI grants you permission to use these resources only for development of an application that uses the TI products described in the resource. Other reproduction and display of these resources is prohibited. No license is granted to any other TI intellectual property right or to any third party intellectual property right. TI disclaims responsibility for, and you fully indemnify TI and its representatives against any claims, damages, costs, losses, and liabilities arising out of your use of these resources.

TI's products are provided subject to [TI's Terms of Sale](#), [TI's General Quality Guidelines](#), or other applicable terms available either on ti.com or provided in conjunction with such TI products. TI's provision of these resources does not expand or otherwise alter TI's applicable warranties or warranty disclaimers for TI products. Unless TI explicitly designates a product as custom or customer-specified, TI products are standard, catalog, general purpose devices.

TI objects to and rejects any additional or different terms you may propose.

Copyright © 2026, Texas Instruments Incorporated

Last updated 10/2025