

## Automotive linear voltage regulator with configurable output voltage having 500 mA current capability


**PowerSSO-12**

### Features

Max. supply voltage (load dump)	$V_S$	40 V
Max. output voltage tolerance	$\Delta V_O$	+/-2%
Output current	$I_O$	500 mA
Quiescent current	$I_{qn}$	$\leq 1 \mu A$ <sup>(1)</sup>

1. Maximum value with regulator disabled

- AEC-Q100 qualified
- Operating DC power supply voltage range from 2.15 V to 28 V
- Battery and post regulation operating modes are allowed
- Low dropout voltage
- Low quiescent current consumption
- User-selectable output voltage (0.8 V; 1.2 V; 1.5 V; 1.8 V; 2.5 V; 2.8 V; 3.3 V or 5 V)
- Output voltage precision  $\pm 2\%$
- Enable input for enabling/disabling the voltage regulator
- Output voltage monitoring with reset output
- Negligible ESR effect on output voltage stability for load capacitor
- Programmable autonomous watchdog through external capacitor
- Undervoltage lockout UVLO
- Fast output discharge
- Thermal shutdown and short-circuit current limitation
- Advanced thermal warning and output overvoltage diagnostic
- Programmable short-circuit output current
- Wide operating temperature range ( $T_J = -40 \text{ }^\circ\text{C}$  to  $175 \text{ }^\circ\text{C}$ )
- Limited documentation available for customers that need support when dealing with ASIL requirements as per ISO 26262

#### Product status link

[L99VR02J](#)

#### Product summary

Order code	L99VR02JTR
Package	PowerSSO-12
Packing	Tape and reel

## Description

L99VR02J is a low dropout linear voltage regulator designed for automotive applications available in PowerSSO-12 packages. The LDO delivers up to 500 mA of load current. It consumes as low as 1  $\mu$ A of quiescent current when the regulator is disabled. The input is 40 V tolerant to withstand load dump, while the operating input voltage range is between 2.15 V and 28 V.

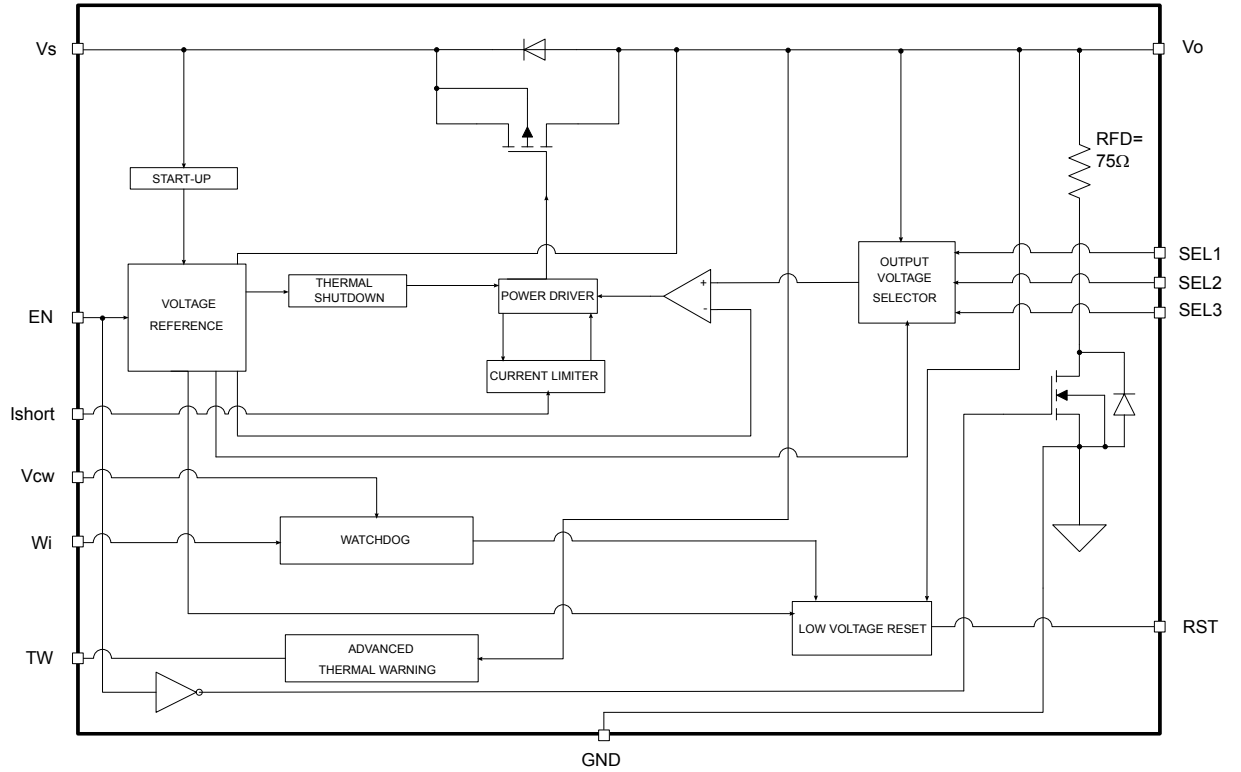
The L99VR02J can be configured, through SELx pins, to generate a fixed selectable output voltage (0.8 V; 1.2 V; 1.5 V; 1.8 V; 2.5 V; 2.8 V; 3.3 V or 5 V). High output voltage accuracy ( $\pm 2\%$ ) is kept over wide temperature range, line, and load variation.

The L99VR02J features enable, reset, autonomous watchdog, advanced thermal warning, fast output discharge, and  $I_{\text{short}}$  control. The regulator output current is internally limited. The device is protected against short-circuit and overload, besides it features over temperature protection. The short current value is configurable by an external resistance.

The L99VR02J can operate both in post regulation, attached to a preregulated voltage or directly connected to the battery.

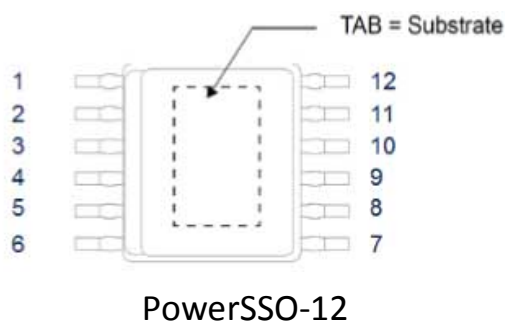
# 1 Block diagram and pins description

Figure 1. Functional block diagram of L99VR02J



**Table 1. Pins description**

Pin name	PowerSSO-12 pin	Function
V <sub>S</sub>	1	Supply voltage. Block directly to the ground with ceramic capacitor $\geq 4.7 \mu\text{F}$ and a 100 nF capacitor as close as possible to the pin
SEL1	2	Output voltage selectors.
SEL2	3	
SEL3	4	
TW	5	Advanced thermal warning output. If the device detects a junction temperature above the warning threshold, the pin is pulled low. If an overvoltage condition occurs, a square wave is provided through the TW output. Leave floating if not used.
I <sub>Short</sub>	6	Programmable short circuit output current input pin. A resistor between I <sub>short</sub> pin and GND sets the short circuit output current value.
EN	7	Enable input: <ul style="list-style-type: none"> <li>With the enable high: Regulator, watchdog, and reset are operating</li> <li>With the enable low: Regulator, watchdog, and reset are shutdown, while the fast discharge circuit is turned on</li> </ul> Connect the enable to V <sub>S</sub> to keep the device always enabled
GND	8	Ground reference.
V <sub>CW</sub>	9	Watchdog timer adjusts. A capacitor between V <sub>CW</sub> pin and GND sets the time response of the watchdog monitor.
Wi	10	Watchdog refresh input. If the square wave frequency at this input pin is too low, a low pulse at an RST pin is generated.
RST	11	Reset output. It is pulled down when the output voltage goes below V <sub>o_th</sub> or the frequency at Wi is too low. Leave floating if not used.
V <sub>O</sub>	12	Voltage regulator output. Block to ground with a capacitor $\geq 3.3 \mu\text{F}$ (needed for regulator stability).
TAB	TAB	Connected to ground

**Figure 2. Pins configuration**


## 2 Electrical specifications

### 2.1 Absolute maximum ratings

Stressing the device above the rating listed in the [Table 2. Absolute maximum ratings](#) may damage to the device permanently. These are stress ratings only. Operations of the device under conditions above those stated in this specification is not implied. Exposure to absolute maximum rating conditions for extended periods may affect device reliability.

**Table 2. Absolute maximum ratings**

Symbol	Parameter	Value	Unit
$V_S$	DC supply voltage	-0.3 to 28	V
$V_S$	Single pulse / $t_{max} < 400$ ms "transient load dump"	40	V
$I_S$	Input current	internally limited	
$V_O$	DC output voltage	-0.3 to 6	V
$I_O$	DC output current	internally limited	
$V_{WI}$	Watchdog input voltage	-0.3 to $V_O + 0.3$	V
$V_{CW}$	Watchdog delay voltage	-0.3 to $V_O + 0.3$	V
$V_{rst}$	Reset output voltage	-0.3 to $V_O + 0.3$	V
$I_{rst}$	Reset output current	Internally limited	
$V_{tw}$	Thermal warning output voltage	-0.3 to $V_O + 0.3$	V
$I_{tw}$	Thermal warning output current	Internally limited	
$V_{sh\_ctrl}$	"Short current" control voltage	-0.3 to 3.6	V
$V_{EN}$	Enable input	-0.3 to $V_S + 0.3$	V
$V_{SELx}$	Selectors input voltage	-0.3 to $V_S + 0.3$	V
VESD HBM	ESD HBM voltage level (HBM-MIL STD 883C)	$\pm 2$	kV
VESD CDM	ESD CDM voltage level (CDM AEC-Q100-011)	$\pm 500$	V
	ESD CDM voltage level on corner pins (CDM AEC-Q100-011)	$\pm 750$	V

## 2.2 Thermal data

### 2.2.1 Thermal resistance

**Table 3. Operation junction temperature**

Item	Symbol	Parameter	Value	Unit
A.001	$R_{thj-case}^{(1)}$	Junction to case thermal resistance	8	°C/W
A.002	$R_{thj-PCB}^{(2)}$	Junction to PCB thermal resistance	10	°C/W
A.003	$R_{thj-amb}^{(3)}$	Junction to ambient thermal resistance	25.5	°C/W

1. Measured on the bottom.
2. Standard JEDEC 51.8.
3. Measured on four layers.

**Note:** The values quoted are for PCB 77 mm x 86 mm x 1.6 mm, FR4, four layers; Cu thickness 0.070 mm (outer layers). Cu thickness 0.035 mm (inner layers), thermal vias separation 1.2 mm, thermal via diameter 0.3 mm +/-0.08 mm, Cu thickness on vias 0.025 mm, footprint dimension 2.2 mm x 2.9 mm.

### 2.2.2 Thermal protection

**Table 4. Temperature threshold**

Item	Symbol	Parameter	Test condition	Min.	Typ.	Max.	Unit
A.004	$T_{prot}^{(1)}$	Thermal protection temperature		175		205	°C
A.005	$T_{prot\_hyst}$	Thermal protection hysteresis			11		°C
A.006	$T_J$	Operating junction temperature	$T_J$	-40		175	°C
A.007	$T_{stg}$	Storage temperature	$T_{stg}$			150	°C

1. Thermal protection is guaranteed by design and characterization.

## 2.3 Electrical characteristics

Values specified in this section are for  $V_S = 2.15\text{ V to }18\text{ V}$ ,  $T_J = -40\text{ °C to }+150\text{ °C}$ , unless otherwise stated.

**Table 5. Electrical characteristics**

Item	Pin	Symbol	Parameter	Test condition	Min.	Typ.	Max.	Unit
A.008	$V_O$	$V_O$	Output voltage	$V_S = 2.15\text{ to }18\text{ V}$ , $I_O = 1\text{ to }500\text{ mA}$ , SEL_CONF = [0;0;0]	0.784	0.8	0.816	V
				$V_S = 2.15\text{ to }18\text{ V}$ , $I_O = 1\text{ to }500\text{ mA}$ , SEL_CONF = [0;0;1]	1.176	1.2	1.224	
				$V_S = 2.15\text{ to }18\text{ V}$ , $I_O = 1\text{ to }500\text{ mA}$ , SEL_CONF = [0;1;0]	1.470	1.5	1.530	
				$V_S = 2.45\text{ to }18\text{ V}$ , $I_O = 1\text{ to }500\text{ mA}$ , SEL_CONF = [0;1;1]	1.764	1.8	1.836	
				$V_S = 3.15\text{ to }18\text{ V}$ , $I_O = 1\text{ to }500\text{ mA}$ , SEL_CONF = [1;0;0]	2.450	2.5	2.550	
				$V_S = 3.45\text{ to }18\text{ V}$ , $I_O = 1\text{ to }500\text{ mA}$ , SEL_CONF = [1;0;1]	2.744	2.8	2.856	
				$V_S = 3.95\text{ to }18\text{ V}$ , $I_O = 1\text{ to }500\text{ mA}$ , SEL_CONF = [1;1;0]	3.234	3.3	3.366	
				$V_S = 5.65\text{ to }18\text{ V}$ , $I_O = 1\text{ to }500\text{ mA}$ , SEL_CONF = [1;1;1]	4.9	5	5.1	
A.009	$V_O$	$I_O$	DC output current	$V_O = 0.8\text{ V}; 1.2\text{ V}; 1.5\text{ V};$ $1.8\text{ V}; 2.5\text{ V}; 2.8\text{ V}; 3.3\text{ V};$ $5\text{ V}$			500	mA
A.010	$V_O$	$I_{\text{short}}$	Short-circuit current lower value <sup>(1)</sup>	$V_S = 4\text{ V}$ for $V_O = 3.3\text{ V}$ , $V_S = 5.8\text{ V}$ for $V_O = 5\text{ V}$ , with $I_{\text{short}}$ pin connected to GND	120	220	320	mA
A.011	$V_O$	$I_{\text{short}}$	Short-circuit current upper value	$V_S = 4\text{ V}$ for $V_O = 3.3\text{ V}$ , $V_S = 5.8\text{ V}$ for $V_O = 5\text{ V}$ , with $I_{\text{short}}$ pin floating; $I_{\text{short}} > I_O$	545	815	1085	mA
A.012	$V_S, V_O$	$\Delta V_O / V_O$	Static line regulation	$V_S$ is from $V_{S\_Low}$ <sup>(2)</sup> to $18\text{ V}$ , $I_O = 1\text{ mA}; 250\text{ mA};$ $500\text{ mA}$ , $V_O = 3.3\text{ V}; 5\text{ V}$			1	%

Item	Pin	Symbol	Parameter	Test condition	Min.	Typ.	Max.	Unit
A.012	V <sub>S</sub> , V <sub>O</sub>	$\Delta V_O / V_O$	Dynamic line regulation <sup>(3)</sup>	V <sub>S</sub> is from V <sub>S_Low</sub> <sup>(2)</sup> to 18 V, T <sub>r</sub> , f = 1 ms; I <sub>O</sub> = 1 mA; 250 mA; 500 mA, V <sub>O</sub> = 3.3 V; 5 V			3	%
A.013	V <sub>O</sub>	$\Delta V_O / V_O$	Static load regulation <sup>(4)</sup>	I <sub>O</sub> = 1 mA to 250 mA, V <sub>O</sub> = 3.3 V for V <sub>S</sub> = 5 V, V <sub>O</sub> = 5 V for V <sub>S</sub> = 6 V			1	%
			Dynamic load regulation <sup>(3)(4)</sup>	I <sub>O</sub> = 10 mA to 250 mA, T <sub>r</sub> , f = 10 $\mu$ s, V <sub>O</sub> = 3.3 V for V <sub>S</sub> = 5 V, V <sub>O</sub> = 5 V for V <sub>S</sub> = 6 V			3	%
A.014	V <sub>S</sub> , V <sub>O</sub>	V <sub>dp</sub>	Drop voltage <sup>(5)</sup>	I <sub>O</sub> = 500 mA, V <sub>O</sub> = 5 V			500	mV
				I <sub>O</sub> = 500 mA, V <sub>O</sub> = 3.3 V				
				I <sub>O</sub> = 500 mA, V <sub>O</sub> = 2.8 V				
				I <sub>O</sub> = 500 mA, V <sub>O</sub> = 2.5 V				
				I <sub>O</sub> = 500 mA, V <sub>O</sub> = 1.8 V				
A.015	V <sub>S</sub> , V <sub>O</sub>	PSRR	Power supply rejection ratio	V <sub>S</sub> = 13.5 V, V <sub>O</sub> = 5 V, I <sub>O</sub> = 500 mA, f = 1 kHz		75 <sup>(3)</sup>		dB
A.016	V <sub>S</sub> , V <sub>O</sub>	I <sub>qn</sub>	Current consumption with regulator disabled I <sub>qn</sub> = I <sub>Vs</sub> - I <sub>O</sub>	V <sub>S</sub> = 3.5 V; 13.5 V, EN = low			1	$\mu$ A
A.057	V <sub>S</sub> , V <sub>O</sub>	I <sub>qn_LL</sub>	Current consumption with regulator enabled I <sub>qn_LL</sub> = I <sub>Vs</sub> - I <sub>O</sub>	V <sub>S</sub> = 3.5 V; 13.5 V, I <sub>O</sub> = 0 $\mu$ A, EN = high		105	130	$\mu$ A
A.017	V <sub>S</sub> , V <sub>O</sub>	I <sub>qn_0</sub>	Current consumption with regulator enabled I <sub>qn_0</sub> = I <sub>Vs</sub> - I <sub>O</sub>	V <sub>S</sub> = 3.5 V; 13.5 V, 0 < I <sub>O</sub> $\leq$ 60 $\mu$ A, EN = high		140	180	$\mu$ A
A.018	V <sub>S</sub> , V <sub>O</sub>	I <sub>qn_50</sub>	Current consumption with regulator enabled I <sub>qn_50</sub> = I <sub>Vs</sub> - I <sub>O</sub>	V <sub>S</sub> = 3.5 V; 13.5 V, I <sub>O</sub> = 50 mA, EN = high		0.55	0.9	mA
A.019	V <sub>S</sub> , V <sub>O</sub>	I <sub>qn_150</sub>	Current consumption with regulator enabled I <sub>qn_150</sub> = I <sub>Vs</sub> - I <sub>O</sub>	V <sub>S</sub> = 3.5 V; 13.5 V, I <sub>O</sub> = 150 mA, EN = high		1	1.5	mA
A.020	V <sub>S</sub> , V <sub>O</sub>	I <sub>qn_250</sub>	Current consumption with regulator enabled I <sub>qn_250</sub> = I <sub>Vs</sub> - I <sub>O</sub>	V <sub>S</sub> = 3.5 V; 13.5 V, I <sub>O</sub> = 250 mA, EN = high		1.05	2	mA
A.021	V <sub>S</sub> , V <sub>O</sub>	I <sub>qn_500</sub>	Current consumption with regulator enabled I <sub>qn_500</sub> = I <sub>Vs</sub> - I <sub>O</sub>	V <sub>S</sub> = 3.5 V; 13.5 V, I <sub>O</sub> = 500 mA, EN = high		1.4	2.5	mA
A.022	V <sub>S</sub>	V <sub>UVLO_fall</sub>	Undervoltage lockout, falling	V <sub>O</sub> = 0.8 V; 1.2 V; 1.5 V; 1.8 V	1.5	1.6	1.7	V
				V <sub>O</sub> = 2.5 V; 2.8 V; 3.3 V	2.3	2.4	2.55	
				V <sub>O</sub> = 5 V	4.6	4.8	5.0	
A.023	V <sub>S</sub>	V <sub>UVLO_rise</sub>	Undervoltage lockout, rising	V <sub>O</sub> = 0.8 V; 1.2 V; 1.5 V; 1.8 V	1.7	1.8	2.1	V
				V <sub>O</sub> = 2.5 V; 2.8 V; 3.3 V	2.6	2.7	2.8	
				V <sub>O</sub> = 5 V	4.9	5.1	5.3	

1. I<sub>Short</sub> typical value of 120 mA for t = 400  $\mu$ s during the power on.

2. V<sub>S\_Low</sub> = 3.5 V at V<sub>O</sub> = 0.8 V; 1.2 V; 1.5 V; 1.8 V and 2.5 V, V<sub>S\_Low</sub> = 5 V at V<sub>O</sub> = 2.8 V and 3.3 V, V<sub>S\_Low</sub> = 6 V at V<sub>O</sub> = 5 V

3. Parameters are guaranteed by design.
4. Referred to [Section 3.1: Load regulation](#).
5. Considering that the minimum operating input voltage is 2.15 V, the dropout voltage ( $V_{dp}$ ) is not defined for output voltages below 1.8 V.

**Table 6. Fast output discharge**

Item	Pin	Symbol	Parameter	Test condition	Min.	Typ.	Max.	Unit
A.024	$V_O$	$R_{FD}$	Fast discharge - pull down resistor	$V_S = 3.95\text{ V}; 13.5\text{ V}$ , $V_O = 3.3\text{ V}; 5\text{ V}$ , EN = low	50	75	120	$\Omega$

**Table 7. Reset**

Item	Pin	Symbol	Parameter	Test condition	Min.	Typ.	Max.	Unit
A.025	RST	$V_{rst\_l}$	Reset output low voltage	$V_S = 5\text{ V}; 13.5\text{ V}$ , $R_{ext} \geq 4.7\text{ k}\Omega$ to $V_O$ , $V_O = 3.3\text{ V}; 5\text{ V}$			$0.2 \times V_O$	V
A.026	RST	$I_{rst\_lkg}$	Reset output high leakage current	$V_{rst} = 0.8\text{ V}$			1	$\mu\text{A}$
A.027	RST	$V_{O\_th}$	$V_O$ out of regulation, low threshold	$V_S = 5\text{ V}; 13.5\text{ V}$ , $V_O$ decreasing, $V_O = 3.3\text{ V}; 5\text{ V}$	13.5%	10%	6.5%	Below $V_O$
A.055	RST	$V_{O\_th\_hyst}$	$V_O$ out of regulation—low threshold hysteresis	$V_S = 5\text{ V}; 13.5\text{ V}$ , $V_O$ increasing, $V_O = 3.3\text{ V}; 5\text{ V}$		2%		$V_{O\_th}$
A.028	RST	$T_{rr}$	Reset reaction time	$V_S = 5\text{ V}; 13.5\text{ V}$ , $V_O = 3.3\text{ V}; 5\text{ V}$	10	16	37	$\mu\text{s}$
A.029	RST	$T_{rd}$	Reset delay time	$V_S = 5\text{ V}; 13.5\text{ V}$ , $V_O = 3.3\text{ V}; 5\text{ V}$	160 <sup>(1)</sup>	250	310	$\mu\text{s}$

1.  $T_{rd} = 120\ \mu\text{s}$  for  $V_S < 3.5\text{ V}$ .

**Table 8. Watchdog**

Item	Pin	Symbol	Parameter	Test condition	Min.	Typ.	Max.	Unit
A.030	W <sub>i</sub>	V <sub>ih</sub>	Input high voltage <sup>(1)</sup>	V <sub>S</sub> = 5 V; 13.5 V, V <sub>O</sub> = 3.3 V; 5 V	0.7 x V <sub>O</sub>			V
A.031	W <sub>i</sub>	V <sub>il</sub>	Input low voltage <sup>(1)</sup>	V <sub>S</sub> = 5 V; 13.5 V, V <sub>O</sub> = 3.3 V; 5 V			0.25 x V <sub>O</sub>	V
A.032	W <sub>i</sub>	I <sub>wi</sub>	Pull down current	V <sub>wi</sub> = 3.3 V		6	10	μA
A.033	V <sub>CW</sub>	V <sub>wth</sub>	Low threshold	V <sub>S</sub> = 5 V; 13.5 V, V <sub>O</sub> = 3.3 V; 5 V	10%	13%	16%	V <sub>O</sub>
A.034	V <sub>CW</sub>	V <sub>wthh</sub>	High threshold	V <sub>S</sub> = 5 V; 13.5 V, V <sub>O</sub> = 3.3 V; 5 V	44%	47%	50%	V <sub>O</sub>
A.035	V <sub>CW</sub>	I <sub>CWc</sub>	Charge current	V <sub>S</sub> = 5 V; 13.5 V, V <sub>CW</sub> = 0.1 V, V <sub>O</sub> = 3.3 V; 5 V	5	10	20	μA
A.036	V <sub>CW</sub>	I <sub>CWd</sub>	Discharge current	V <sub>S</sub> = 5 V; 13.5 V, V <sub>CW</sub> = 2.5 V, V <sub>O</sub> = 3.3 V; 5 V	1.25	2.5	5	μA
A.040	V <sub>O</sub>	I <sub>w_off</sub>	Watchdog deactivation current threshold	V <sub>S</sub> = 5 V; 13.5 V, V <sub>O</sub> = 3.3 V; 5 V	0.4	1.05	1.5	mA
A.041	V <sub>O</sub>	I <sub>w_on</sub>	Watchdog activation current threshold	V <sub>S</sub> = 5 V; 13.5 V, V <sub>O</sub> = 3.3 V; 5 V	1.8	3.35	4.8	mA

1. Watchdog input requires a square wave signal (duty cycle of 50 %).

**Table 9. Enable**

Item	Pin	Symbol	Parameter	Test condition	Min.	Typ.	Max.	Unit
A.042	EN	V <sub>EN_low</sub>	EN input low voltage				0.6	V
A.043	EN	V <sub>EN_high</sub>	EN input high voltage		1.5			V
A.045	EN	I <sub>EN</sub>	Pull down current	V <sub>S</sub> = 13.5 V		4	12	μA

**Table 10. Output voltages selectors**

Item	Pin	Symbol	Parameter	Test condition	Min.	Typ.	Max.	Unit
A.046	SELx	V <sub>SELx_low</sub>	SELx input low voltage				0.3	V
A.047	SELx	V <sub>SELx_high</sub>	SELx input high voltage		0.7			V
A.048	SELx	I <sub>SELx</sub>	Pull down current	V <sub>S</sub> = 3.5 V; 13.5 V		0.1	0.4	μA

**Table 11. Thermal warning and protection**

Item	Pin	Symbol	Parameter	Test condition	Min.	Typ.	Max.	Unit
A.049	TW	$V_{TW\_low}$	Thermal warning output low voltage	$R_{ext} \geq 4.7 \text{ k}\Omega$ to $V_O$ , $V_O = 3.3 \text{ V}; 5 \text{ V}$			$0.2 \times V_O$	V
A.050	TW	$T_{warn}$	Thermal warning temperature		140	150	165	°C
A.051	TW	$T_{warn\_hyst}$	Thermal warning hysteresis		3	11	15	°C
A.052	$V_O$	OV	$V_O$ overvoltage	$V_S = 5 \text{ V}; 13.5 \text{ V}$ , $V_O$ increasing, $V_O = 3.3 \text{ V}; 5 \text{ V}$	6.5%	10%	13.5%	Above $V_O$
A.056	$V_O$	OV_hyst	$V_O$ overvoltage hysteresis	$V_S = 5 \text{ V}; 13.5 \text{ V}$ , $V_O$ decreasing, $V_O = 3.3 \text{ V}; 5 \text{ V}$		2%		Below OV
A.054	TW	$T_{w\_per}$	Thermal warning square wave period	$V_S = 5 \text{ V}; 13.5 \text{ V}$ , $V_O = 3.3 \text{ V}; 5 \text{ V}$	160 <sup>(1)</sup>	250	335	$\mu\text{s}$

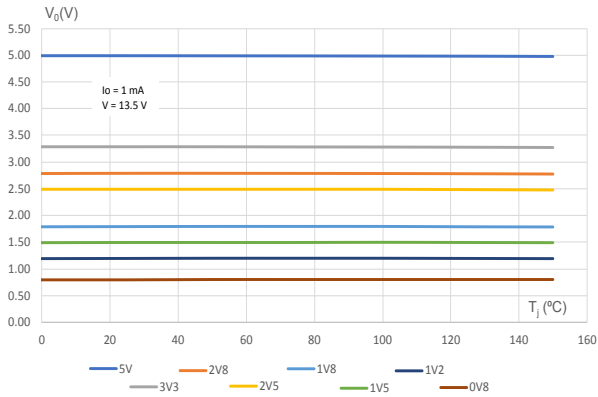
1.  $T_{w\_per} = 130 \mu\text{s}$  for  $V_S < 3.5 \text{ V}$ .

**Note:** All parameters are guaranteed in the junction temperature range  $-40^\circ\text{C}$  to  $150^\circ\text{C}$  (unless otherwise specified). L99VR02J device is still operative and functional at higher temperatures (up to  $175^\circ\text{C}$ ). Parameters limit at junction temperature above  $150^\circ\text{C}$  may change respect to what is specified as per the standard temperature range. Device functionality at high junction temperature is guaranteed by characterization. All parameters are guaranteed by design for  $V_O$  not reported in test condition.

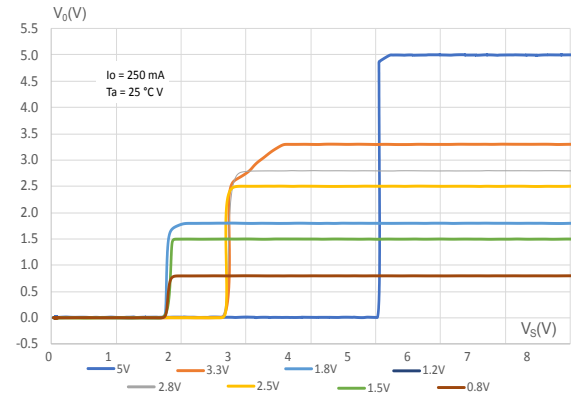
**Note:** Minimum input voltage values are achievable adopting an input ceramic capacitor: C5750X7R2A475M230KA—ceramic capacitor multistrata SMD,  $4.7 \mu\text{F}$ ,  $100 \text{ V}$ ,  $\pm 20\%$ , X7R, C series TDK.

## 2.4 Electrical characteristics curves

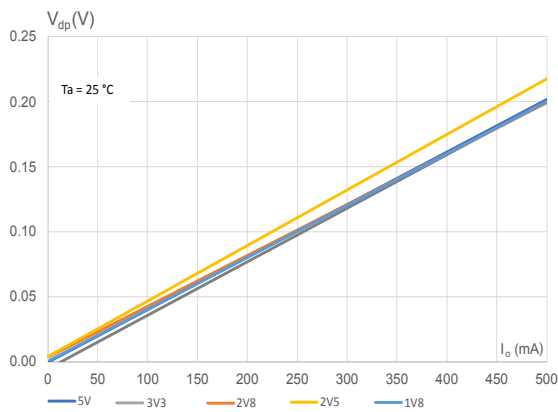
**Figure 3. Output voltage vs  $T_j$**



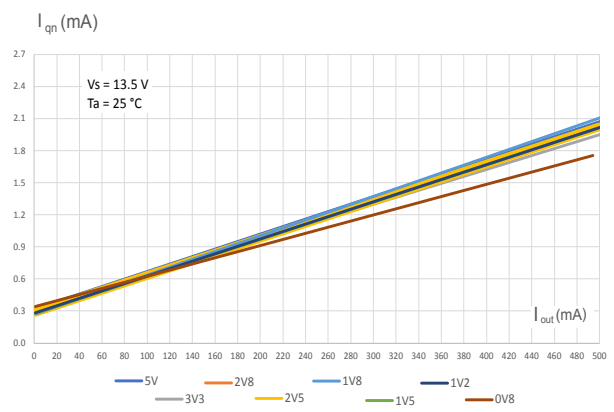
**Figure 4. Output voltage vs  $V_s$**



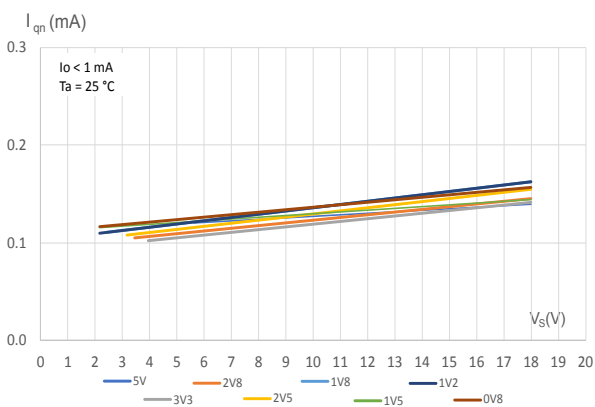
**Figure 5. Drop voltage vs output current**



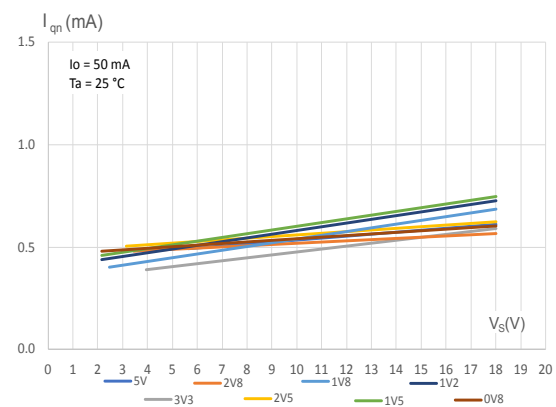
**Figure 6. Current consumption vs output current**



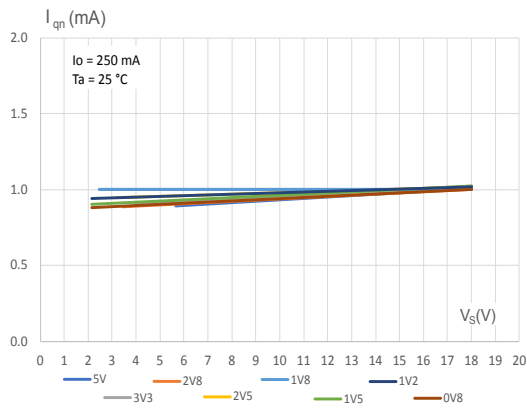
**Figure 7. Current consumption vs input voltage ( $I_o < 1 \text{ mA}$ )**



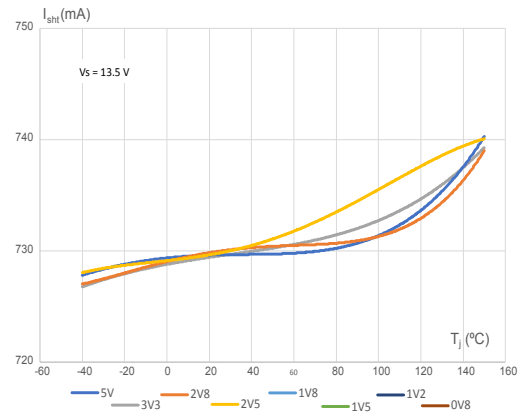
**Figure 8. Current consumption vs input voltage ( $I_o = 50 \text{ mA}$ )**



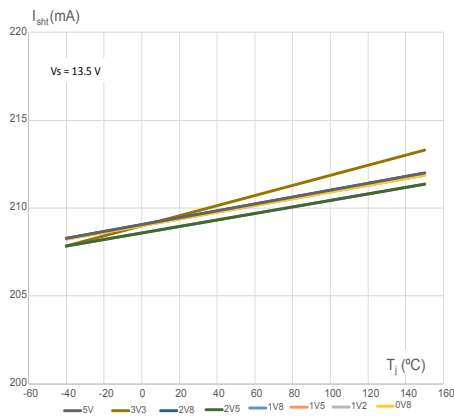
**Figure 9. Current consumption vs input voltage ( $I_o = 250 \text{ mA}$ )**



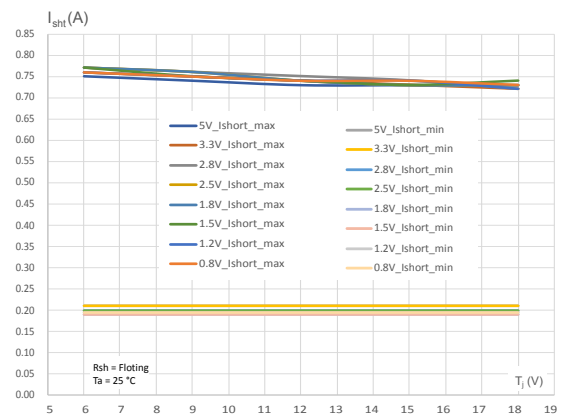
**Figure 10. Short-circuit current vs  $T_j$  ( $I_{short}$  pin tied to GND)**



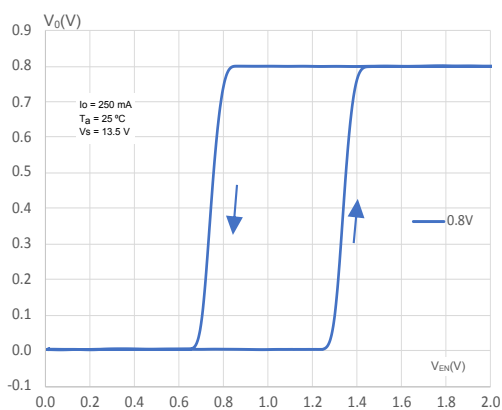
**Figure 11. Short-circuit current vs  $T_j$  ( $I_{short}$  pin floating)**



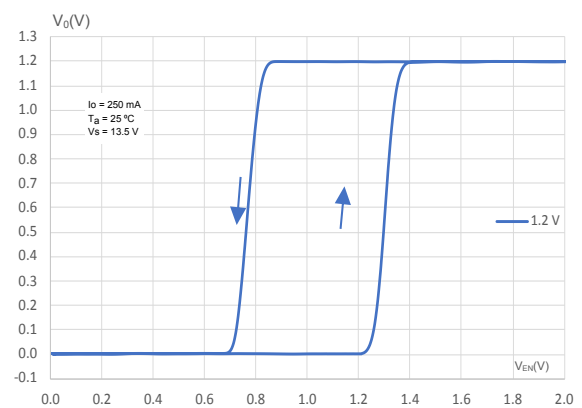
**Figure 12. Short-circuit current vs input voltage**



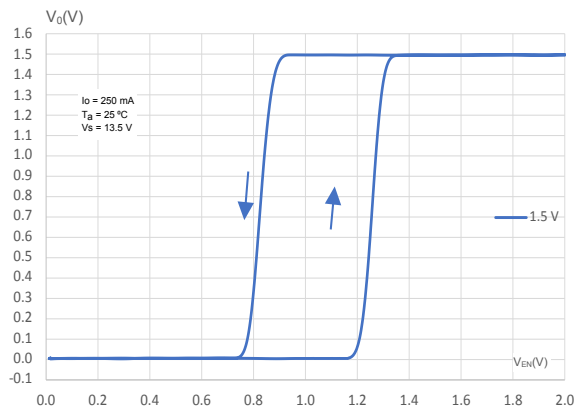
**Figure 13. Output voltage vs enable voltage ( $V_o = 0.8 \text{ V}$ )**



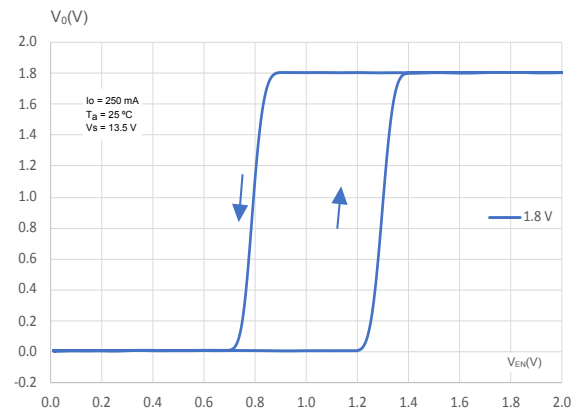
**Figure 14. Output voltage vs enable voltage ( $V_o = 1.2 \text{ V}$ )**



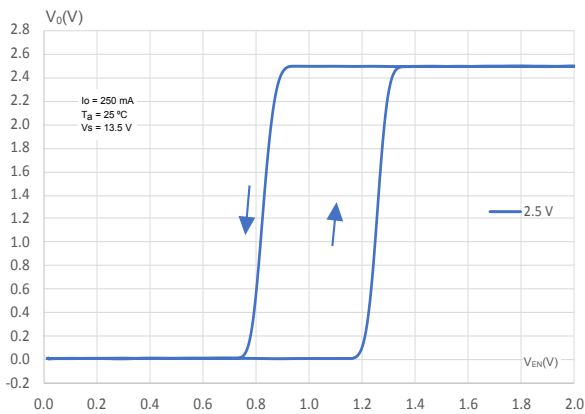
**Figure 15. Output voltage vs enable voltage ( $V_O = 1.5\text{ V}$ )**



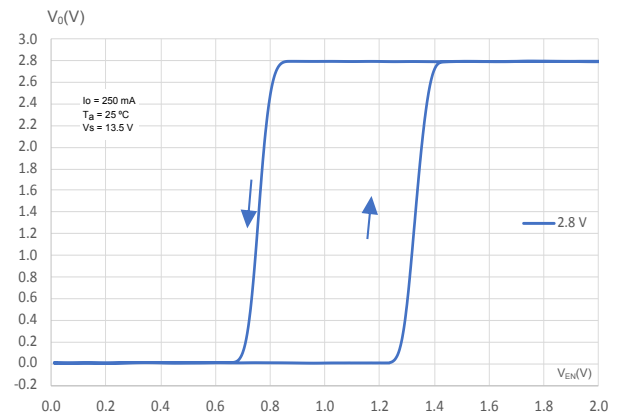
**Figure 16. Output voltage vs enable voltage ( $V_O = 1.8\text{ V}$ )**



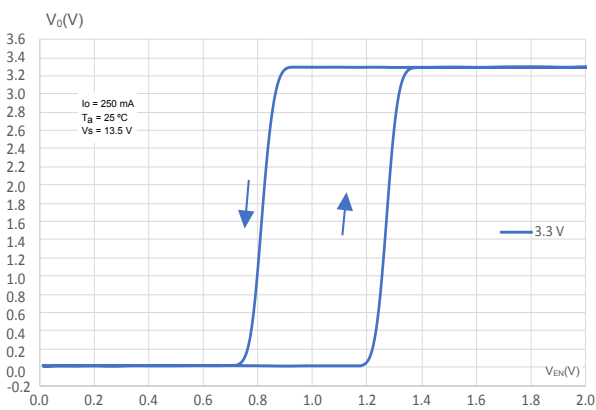
**Figure 17. Output voltage vs enable voltage ( $V_O = 2.5\text{ V}$ )**



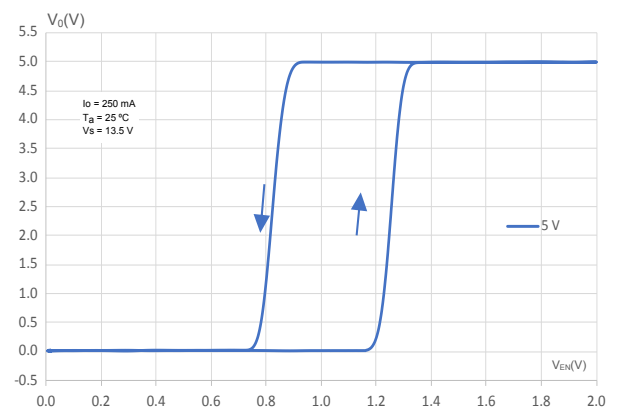
**Figure 18. Output voltage vs enable voltage ( $V_O = 2.8\text{ V}$ )**



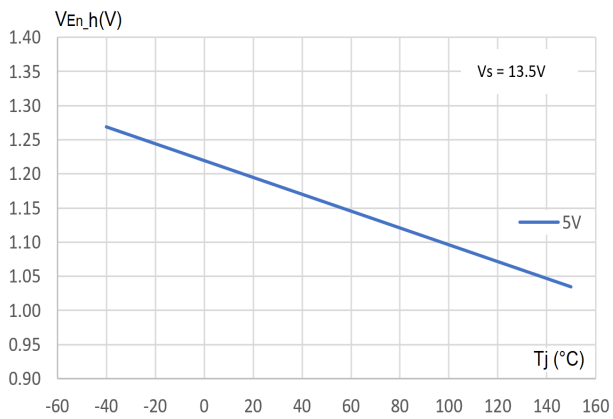
**Figure 19. Output voltage vs enable voltage ( $V_O = 3.3\text{ V}$ )**



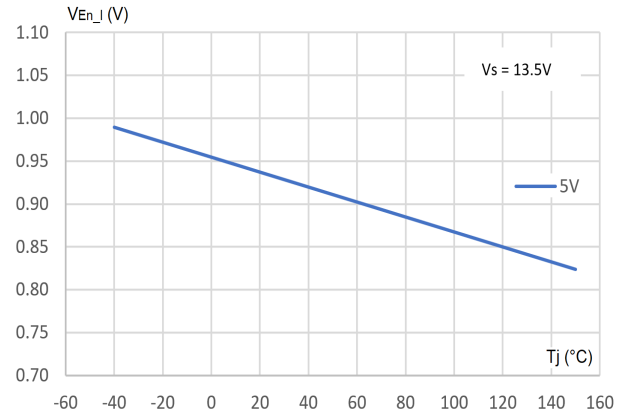
**Figure 20. Output voltage vs enable voltage ( $V_O = 5\text{ V}$ )**



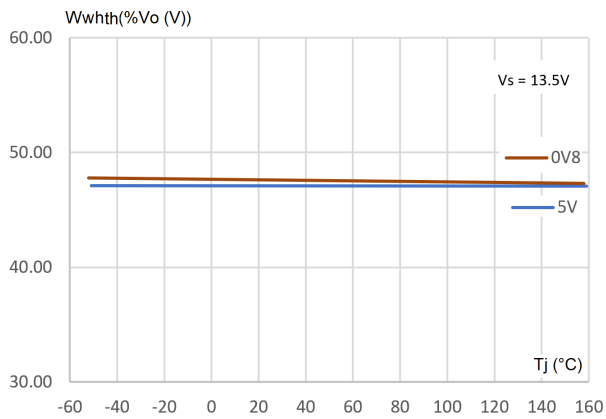
**Figure 21.  $V_{EN\_high}$  vs  $T_j$**



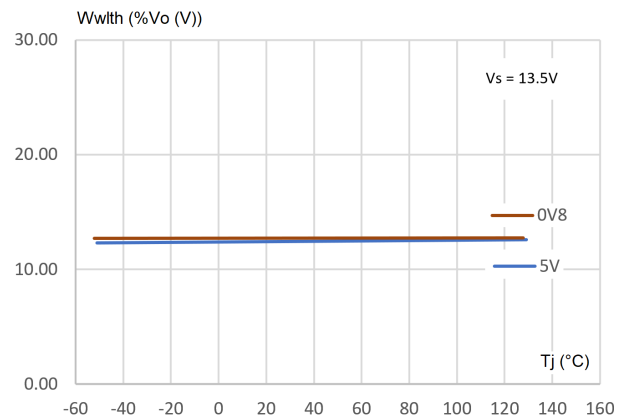
**Figure 22.  $V_{EN\_low}$  vs  $T_j$**



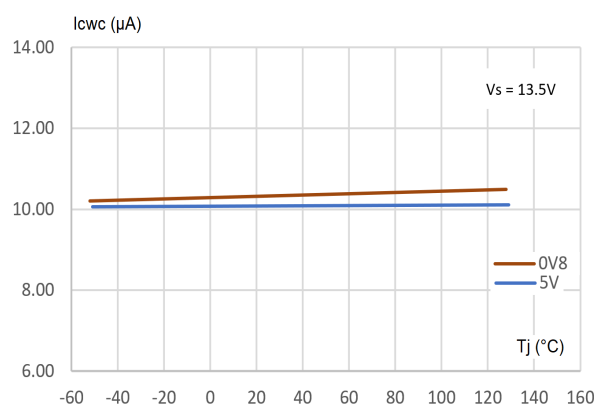
**Figure 23.  $V_{whth}$  vs  $T_j$**



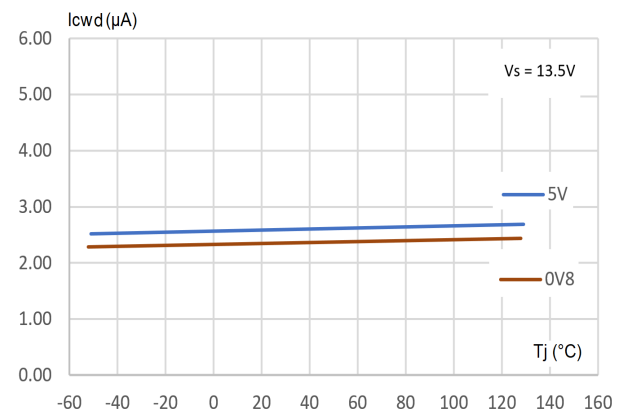
**Figure 24.  $V_{wth}$  vs  $T_j$**

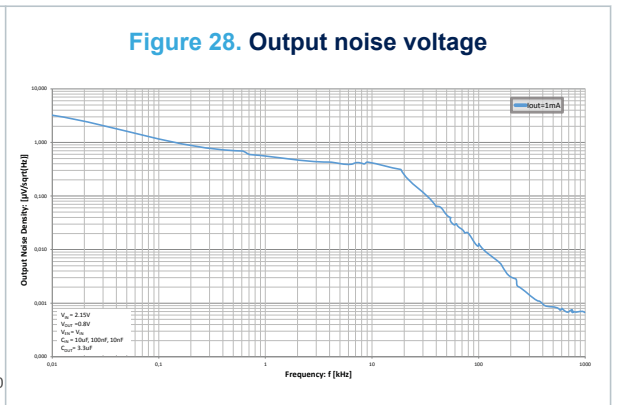
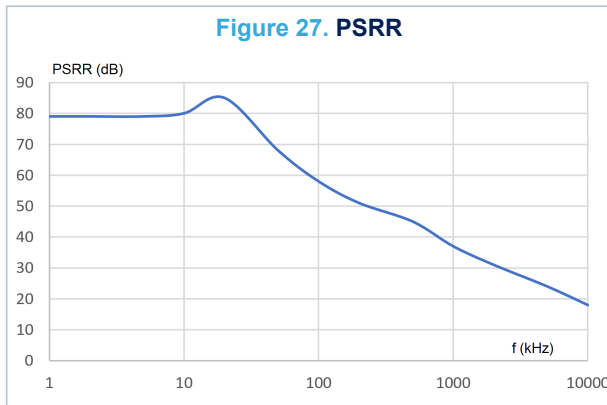


**Figure 25.  $I_{cwc}$  vs  $T_j$**



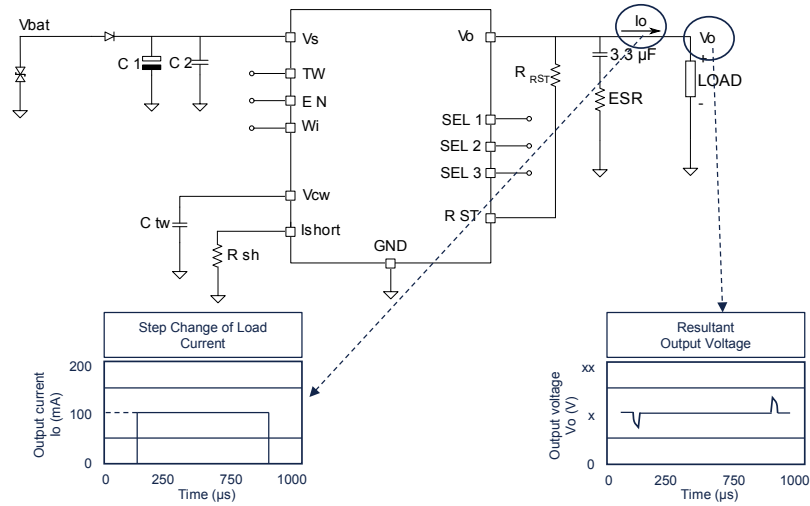
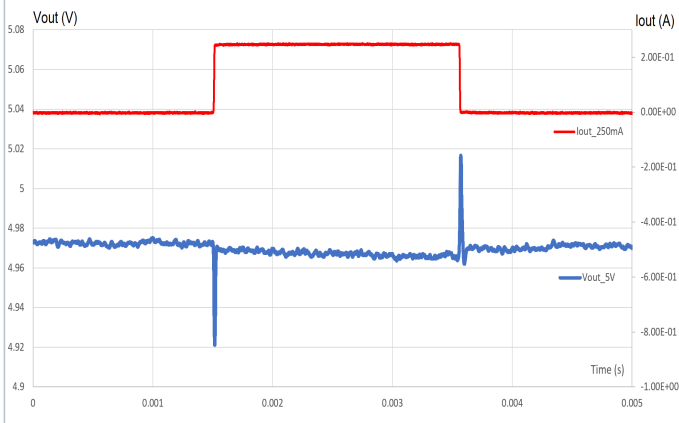
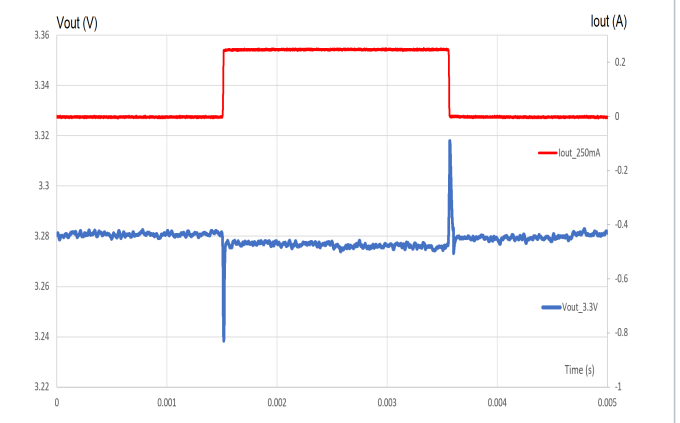
**Figure 26.  $I_{cwd}$  vs  $T_j$**





### 3 Test circuit and waveforms plot

#### 3.1 Load regulation

**Figure 29. Load regulation test circuit**

**Figure 30. Maximum load variation response ( $V_o = 5\text{ V}$ )**

**Figure 31. Maximum load variation response ( $V_o = 3.3\text{ V}$ )**


## 4 Application information

Figure 32. Application schematic

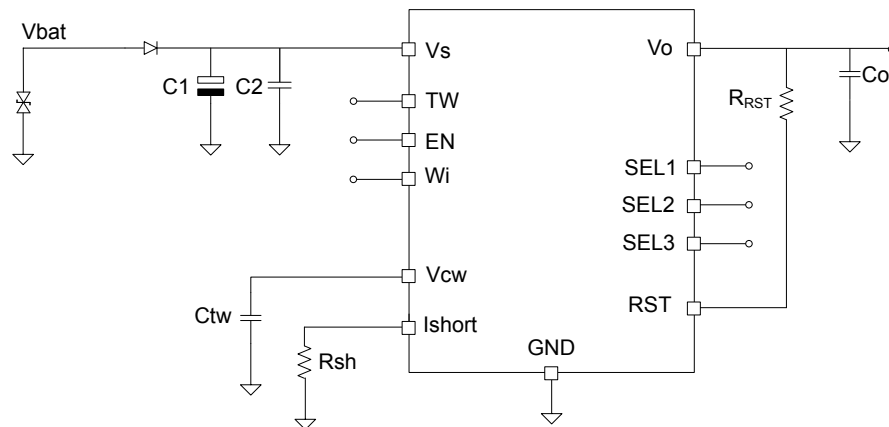
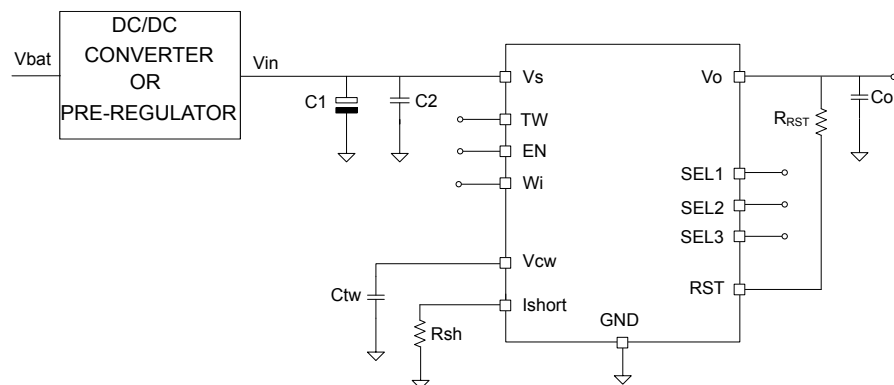


Figure 33. Application schematic – Post regulation



Input ceramic capacitor  $C_2 \geq 4.7 \mu\text{F}$  is necessary for the regulator to operate properly. The other input capacitor  $C_1$  can be used as backup supply for the application. The  $C_O$  capacitor, connected to the output pin, is for bypassing to GND the high-frequency noise and it guarantees stability even during sudden line and load variations.

Suggested value is  $C_O = 3.3 \mu\text{F}$ .

The ESR of the SMD output ceramic capacitor has a negligible effect on the stability of the L99VR02J for capacitors with low ESR. A ceramic SMD capacitor is recommended on the  $V_O$  pin.

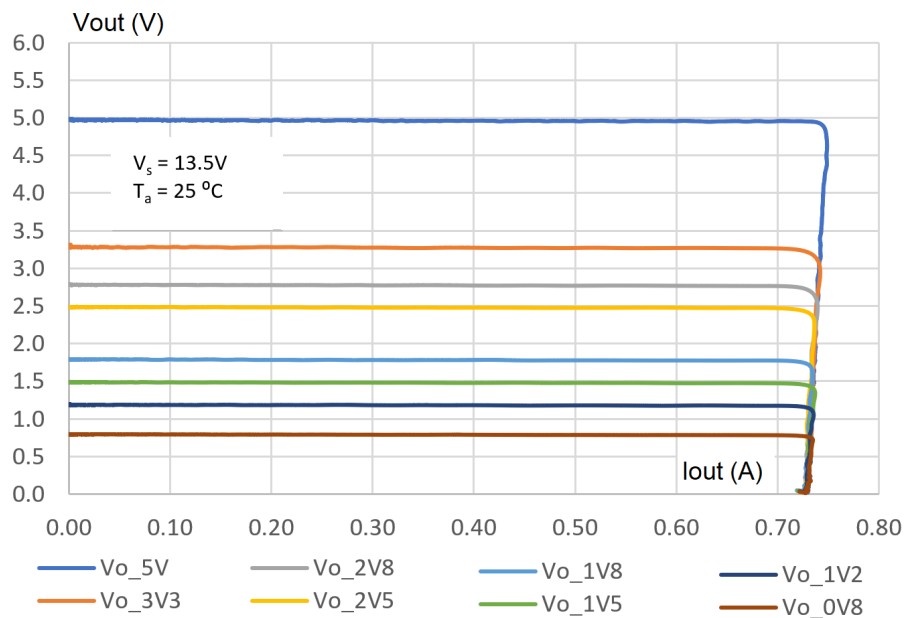
### 4.1 Voltage regulator

The voltage regulator uses a p-channel MOS transistor as a regulating element. With this structure, a very low dropout voltage at current up to  $I_O = 500$  mA is obtained. The high-precision of the output voltage ( $\pm 2\%$ ) is obtained with a pretrimmed reference voltage. The voltage regulator automatically adapts its own quiescent current to the output current level. In light load conditions, the quiescent current goes down to  $I_{qn\_LL} = 105$   $\mu A$  (low consumption mode). L99VR02J operates with reduced input voltage (post regulation) minimizing the internal power dissipation and maximizing the output current.

### 4.2 Output current limitation

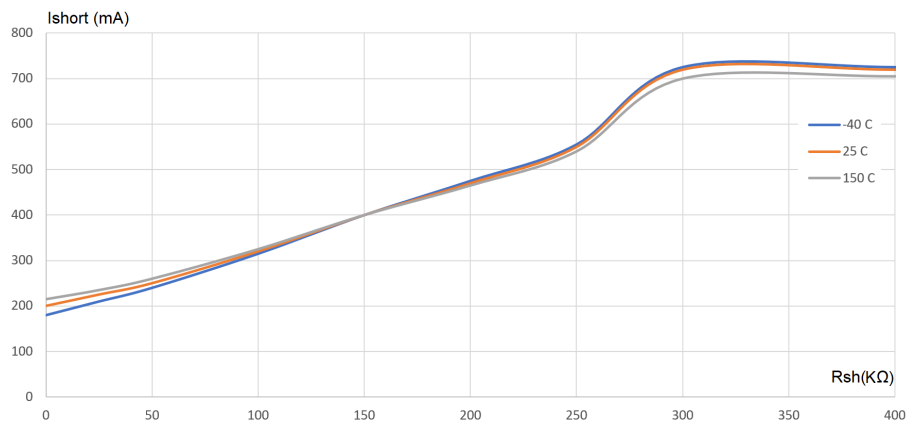
Output current limitation is present to protect the regulator and the application from the overload condition, such as short to ground.

**Figure 34. Behavior of output current versus regulated voltage  $V_O$**



The  $I_{short}$  current can be set in the range from 220mA (typ) to 815mA (typ). This through an external resistor  $R_{sh}$  connected between the  $I_{short}$  pin and the ground.

**Figure 35.  $I_{short}$  versus  $R_{sh}$**



Open pin (no resistance on the  $I_{short}$  pin), is seen as a max resistance corresponding to the maximum  $I_{short}$  current.

### 4.3 Output voltage selection

The L99VR02J can provide one out of eight different output voltages. The combination of three digital input selectors (SELx) determines the output voltage according to the following Table 12.

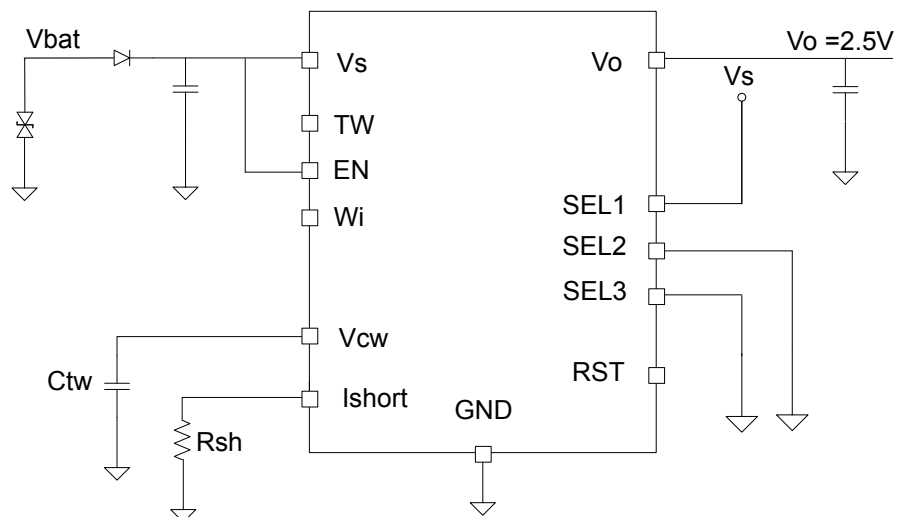
**Table 12. Truth table**

$V_o$	SEL1	SEL2	SEL3
5	1	1	1
3.3	1	1	0
2.8	1	0	1
2.5	1	0	0
1.8	0	1	1
1.5	0	1	0
1.2	0	0	1
0.8 (default)	0	0	0

The SELx pins configuration is acquired at the device startup (EN transition from low to high) and once configuration is acknowledged. It cannot be changed until the next EN transition.

When all the pins are left not connected, the default configuration is selected.

**Figure 36. Example of output voltage selection**



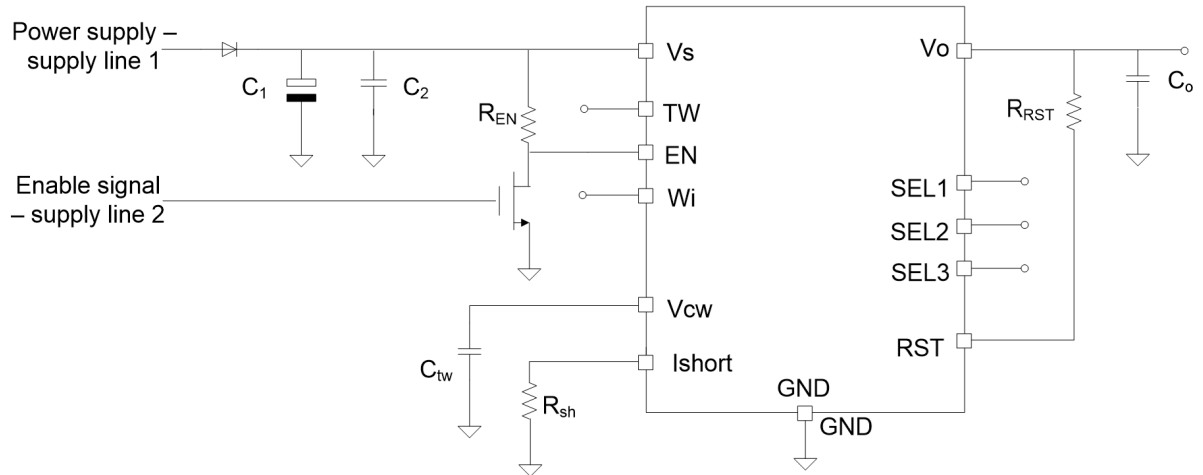
SELx pins are internally connected to GND via the pull-down current source.

### 4.4 Enable

The L99VR02J is enabled/disabled by the enable input; a high voltage signal switches the regulator ON. When the enable pin is set low, the output is switched-off. The current consumption of the device becomes as low as 1  $\mu$ A and the fast output discharge circuit is activated.

It may happen that the components drive the enable pin supplied at a voltage different from the regulator supply voltage. In this case, the EN input pin must be set high only once  $V_S > 1.5\text{ V}$ . A solution to drive the enable pin is depicted in the Figure 37.

Figure 37. Typical example of enable control

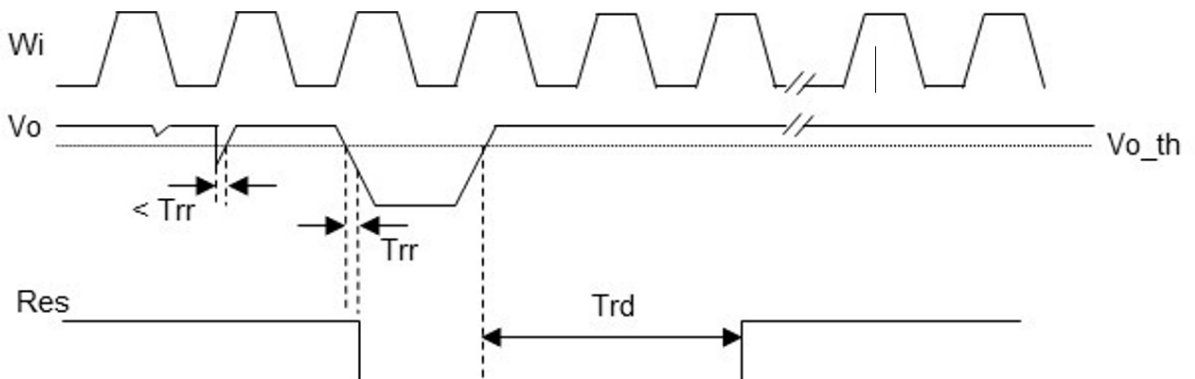


In any case, to avoid exceeding the absolute maximum rating, a special care must be adopted in driving the EN pin since the enable input voltage is linked to the maximum DC supply voltage ( $V_S$ ) applied to the L99VR02J (-0.3 V to  $V_S + 0.3\text{ V}$ ).

## 4.5 Reset

The reset circuit supervises the output voltage  $V_O$ . If the output voltage falls below  $V_{O\_th}$ , then RST is pulled low with a reaction time  $T_{rr}$ . When the output voltage rises above,  $V_{O\_th} + V_{O\_th\_hyst}$  then RST is pulled high with a delay time  $T_{rd}$ . An internal circuit generates the delay. The reset circuit is active when EN is high. Being RST an open-drain output an external resistance ( $R_{rst}$ ) is needed between the RST pin and the  $V_O$  pin. The external resistance value can be in a range between 4.7 K $\Omega$  and 20 K $\Omega$ . Leave the RST pin floating if not used. Be aware that the current flowing through the RST pin drawn from  $V_O$  when the RST pin is pulled low. It may affect the watchdog activation/deactivation based on the regulator output current consumption monitoring.

Figure 38. Reset timing diagram



## 4.6 Autonomous watchdog

The watchdog input  $W_i$  monitor a supplied microcontroller. If pulses are missing, the RST output pin is set low. The watchdog timeout can be set within a wide range with the external capacitor,  $C_{tw}$ . The watchdog circuit discharges the capacitor  $C_{tw}$ , with the constant current  $I_{CWd}$ . If the lower threshold  $V_{wlth}$  is reached, a watchdog reset is generated. To avoid it, the microcontroller must generate a positive edge during the discharge of the capacitor before the voltage reaches the threshold  $V_{wlth}$ . To calculate the sawtooth period “ $T_{wop}$ ”, taking care that the microcontroller triggers the positive edge during the discharge phase of  $C_{tw}$  ( $T_d$ ). The following equations can be used:

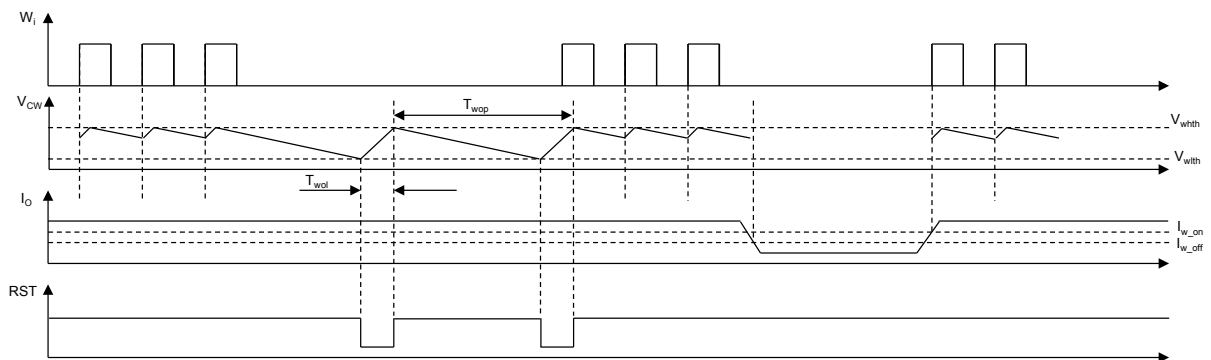
$$(V_{whth} - V_{wlth}) \times C_{tw} = I_{CWd} \times T_d$$

$$(V_{whth} - V_{wlth}) \times C_{tw} = I_{CWc} \times T_{wol}$$

$$T_{wop} = T_d + T_{wol}$$

Every  $W_i$  positive edge switches the current source from discharging to charging. The same happens when the lower threshold is reached. When the voltage reaches the upper threshold,  $V_{whth}$ , the current switches from charging to discharging. The result is a saw-tooth voltage at the watchdog timer capacitor  $C_{tw}$ . If a microcontroller operates in low power mode, it is not able to generate any pulse to refresh the voltage regulator watchdog, triggering so the microcontroller reset. In such a case, the watchdog functionality is automatically deactivated anytime the microcontroller current consumption falls under the  $I_{w\_off}$  threshold. This to avoid generating the microcontroller reset. On the other hand, when the current consumption rises above the  $I_{w\_on}$  threshold the watchdog functionality is once again activated. Once the regulator is enabled for the first time, if  $I_O < I_{w\_off}$ , the watchdog is not activated. While if  $I_O > I_{w\_off}$ , the watchdog is activated.

**Figure 39. Watchdog timing diagram**



Since the RST output pin is shared by the watchdog circuit and the output voltage monitoring circuit, for applications where the watchdog is not needed, to prevent the watchdog from generating RST pulses without anyhow losing the reset functionality of the  $V_O$  monitoring, the  $V_{cw}$  pin has to be connected to  $V_O$ .  $V_{cw}$  pin must be always tied to ground by an external capacitor ( $C_{tw}$ ) when watchdog function is used.

**Note:** when the watchdog timer is used and the regulator recovers from a thermal shut-down event or recovers from an output under-voltage event (including the recovery from output under-voltage event at the regulator output turning on), the reset pin might be pulled back high with a delay longer than  $T_{rd}$ , in the range between  $T_{rd}$  and  $T_{rd} + T_{wol}$  due to the watchdog that might affect the RST pin release. The watchdog will not affect the RST pin release in the case where recovering from a thermal shut-down event or recovering from an output under-voltage event (including the recovery from output under-voltage event at the regulator output turning on) the  $I_O$  drops below  $I_{w\_off}$  before  $T_{rd}$ . The output current  $I_O$  consists in the load current, the current drawn from the RST pin and the TW pin through the pull-down resistors connected to  $V_O$  when the RST and the TW pins are asserted low and the current needed to charge/discharge the output capacitor  $C_O$ .

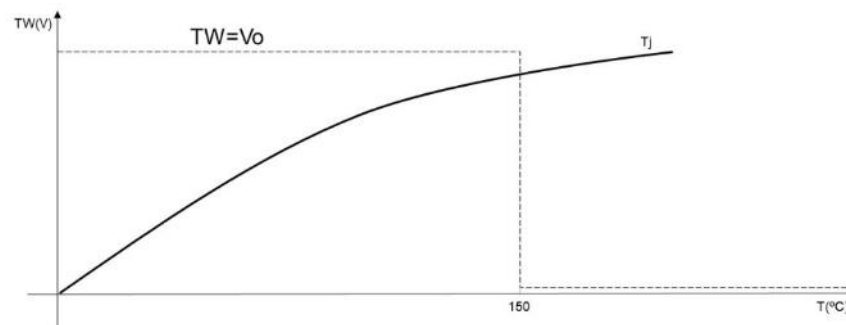
**Note:** When the watchdog timer is used, in the case of an output under-voltage event not making the  $V_O$  drop to zero volt, since the watchdog will still be running during the output under-voltage condition, the first watchdog timeout after the reset pin is released coming out of the output under-voltage event might occur before expected ( $0 \leq \text{timeout} \leq T_{wop} - T_{wo}$ ).

**Table 13. Watchdog timer**

Usage of watchdog timer	Connection of $V_{CW}$ pin
Watchdog timer is not used	Connect to the $V_O$ pin
Watchdog timer is used	Connect to an external capacitor $C_{TW}$

## 4.7 Thermal warning and thermal shutdown

To warn the microcontroller about a severe temperature increase, a thermal warning output has been implemented. If the device detects a junction temperature above  $T_{warm}$ , the advanced thermal warning (TW) output pin is pulled low while the voltage regulator, and its features remain all active. The TW pin returns to its high logic level (equal to the  $V_O$  output value) once the temperature falls below the threshold  $T_{warm} - T_{warm\_hyst}$ .

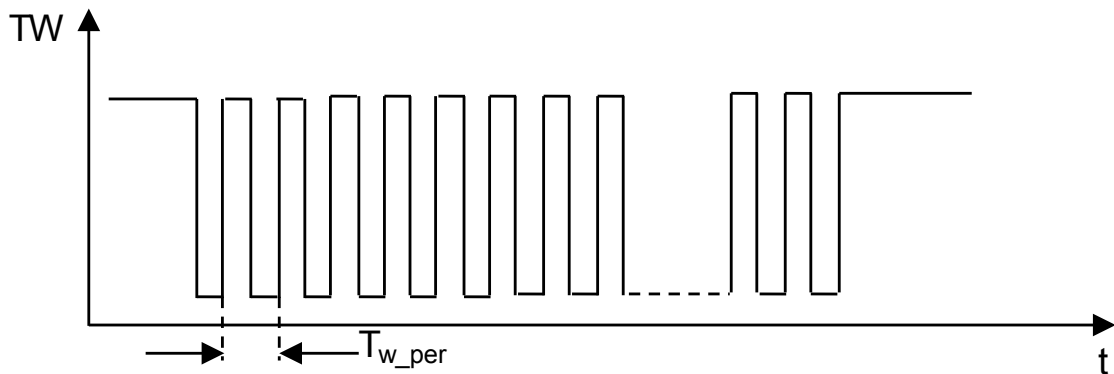
**Figure 40. Thermal warning diagram**


When junction temperature reaches the  $T_{prot}$  thermal shutdown threshold the regulator output is quickly shut-off through the internal fast output discharge circuit; to be reactivated, junction temperature has to decrease below  $T_{prot} - T_{prot\_hyst}$ . Being TW an open-drain output an external resistance ( $R_{TW}$ ) is needed between the TW pin and the  $V_O$  pin. The external resistance value can be in a range between 4.7 K $\Omega$  and 20 K $\Omega$ . Be aware that the current flowing through the TW pin drawn from  $V_O$  when the TW pin is pulled low may affect the watchdog activation/deactivation based on the regulator output current consumption monitoring. Leave floating if not used.

## 4.8 Overvoltage detection by advanced thermal warning read-out

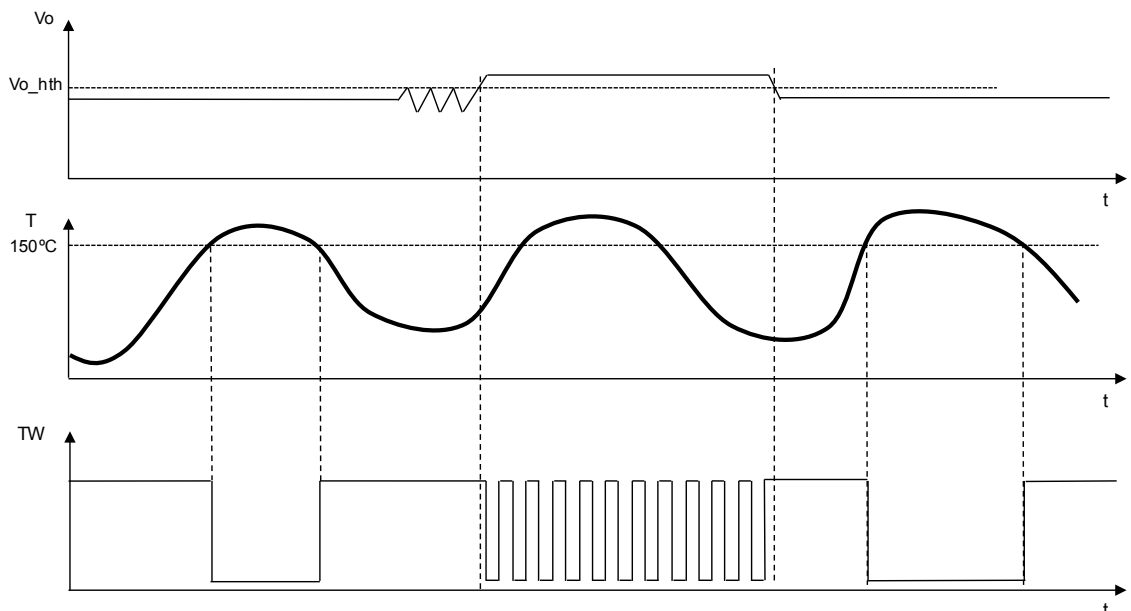
The TW pin also provides diagnostics about output overvoltage (OV); to distinguish between a thermal warning event and an output overvoltage event, two different signals are generated at the same TW output pin. How reported in the previous paragraph a thermal warning event detection sets the TW pin LOW, instead an output overvoltage event generates a square wave at the TW pin (Figure 41. Square wave on TW pin generated during an overvoltage). Overvoltage detection has higher priority than thermal warning detection so that concurrence of thermal warning and over voltage events lead to a square wave like in the case of overvoltage detection (as shown in Figure 42. Warning signal caused by overvoltage and thermal warning on TW pin).

Figure 41. Square wave on TW pin generated during an overvoltage



A typical example of thermal warning and overvoltage failures management is depicted in Figure 42. Warning signal caused by overvoltage and thermal warning on TW pin.

Figure 42. Warning signal caused by overvoltage and thermal warning on TW pin



## 4.9 Fast output discharge

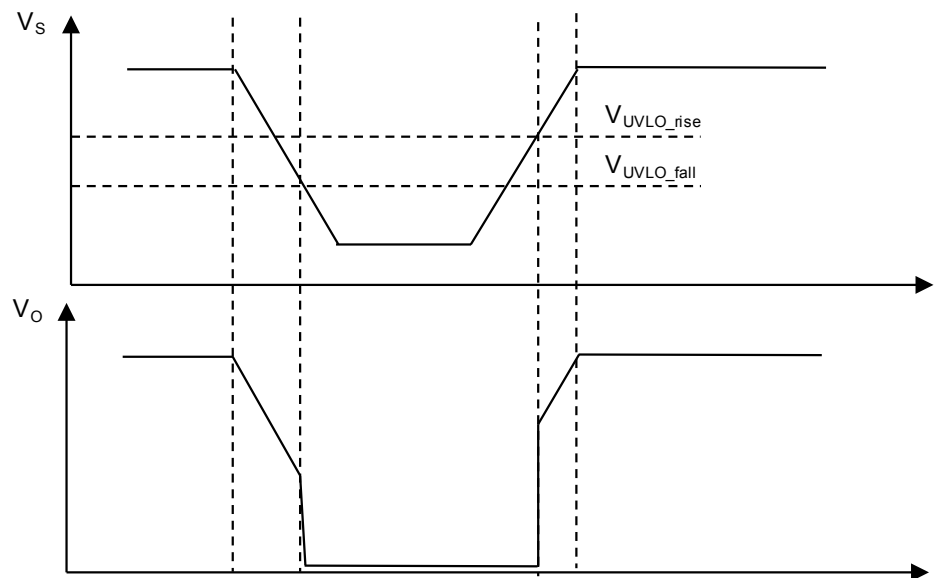
To assure a quick discharge of the external capacitor tied to the output pin down to around 1.3 V the L99VR02J uses an internal pulldown circuit. Activated each time the EN pin goes low, during thermal shutdown and during undervoltage lockout, the output current flows through the pulldown resistor of the fast output discharge circuit to the ground. The fast output discharge feature is available for the output voltages,

$V_O = 2.5\text{ V}$  (SELx = [1;0;0]);  $V_O = 2.8\text{ V}$  (SELx = [1;0;1]);  $V_O = 3.3\text{ V}$  (SELx = [1;1;0]) and  $V_O = 5\text{ V}$  (SELx = [1;1;1]).

#### 4.10 Undervoltage lockout UVLO

The undervoltage lockout (UVLO) circuit allows a fast regulating element to turn off (activating the internal fast output discharge circuit). This if the input voltage drops below the threshold,  $V_{UVLO\_fall}$ , avoiding an undesired unknown output state during low input voltage. When the input voltage is above the  $V_{UVLO\_rise}$  threshold, the regulating element is again turned on.

Figure 43. Undervoltage lock out on output voltage



## 4.11 Support to ISO26262

Even if not designed as the safety HW element, the device contains some features that can be used to support the application that needs to fulfill functional safety requirements. Analysis of the IC's capability to reach the required safety level, should be made at system level under user responsibility.

The following device safety requirements have been considered for a typical application:

**Table 14. Safety requirement**

ID	Description
SR-001	Operation of voltage regulator is allowed until over the temperature limit.
SR-002	Operation of voltage regulator is enabled until the programmed current limit is reached.
SR-003	Output voltage of regulator shall remain within programmed range when the RST pin is not asserted.
SR-004	Output voltage of the regulator shall remain within programmed range when the square wave at the TW pin is not generated.

Based on the above requirements list the following safety mechanism has been implemented:

**Table 15. Implemented safety mechanism**

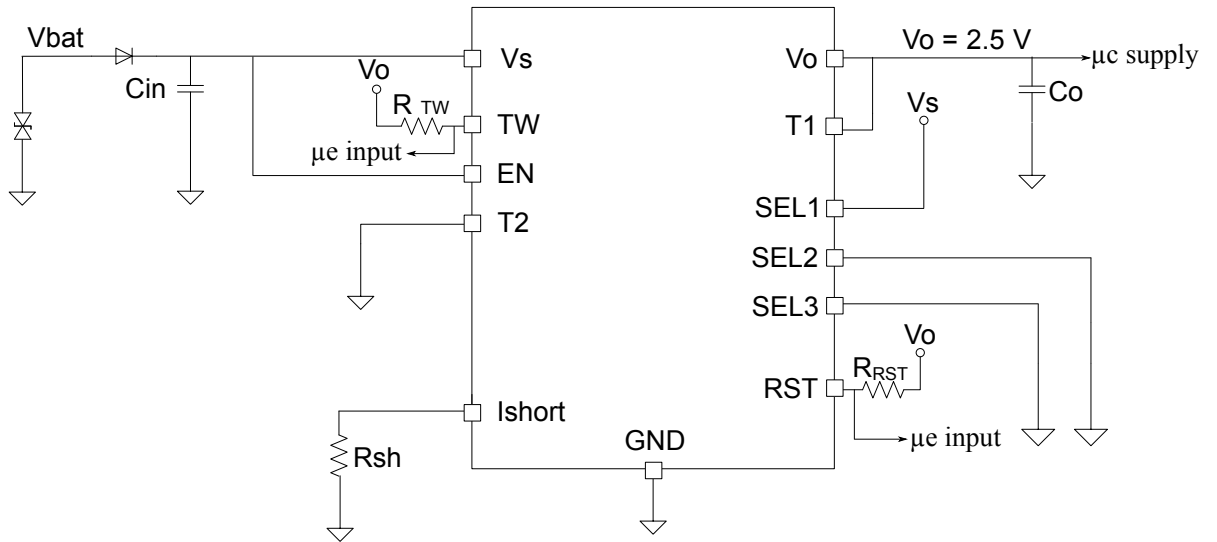
ID	Description	SR covered
SM1	Thermal sensor acting by the TW pin	SR-004
SM2	Overtemperature protection	SR-001
SM3	Limitation on maximum output current	SR-002
SM4	Output voltage $V_O$ monitoring for undervoltage detection	SR-002
SM5	Output voltage $V_O$ monitoring for overvoltage detection	SR-002
SM6	RST reset assertion in case of $V_O$ undervoltage detection	SR-003

In addition to the internal watchdog for checking the correct operation of the microcontroller, it can be considered a system-level safety mechanism.

More details about functional safety can be found in the device safety manual, provided on customer request.

## 5 Application

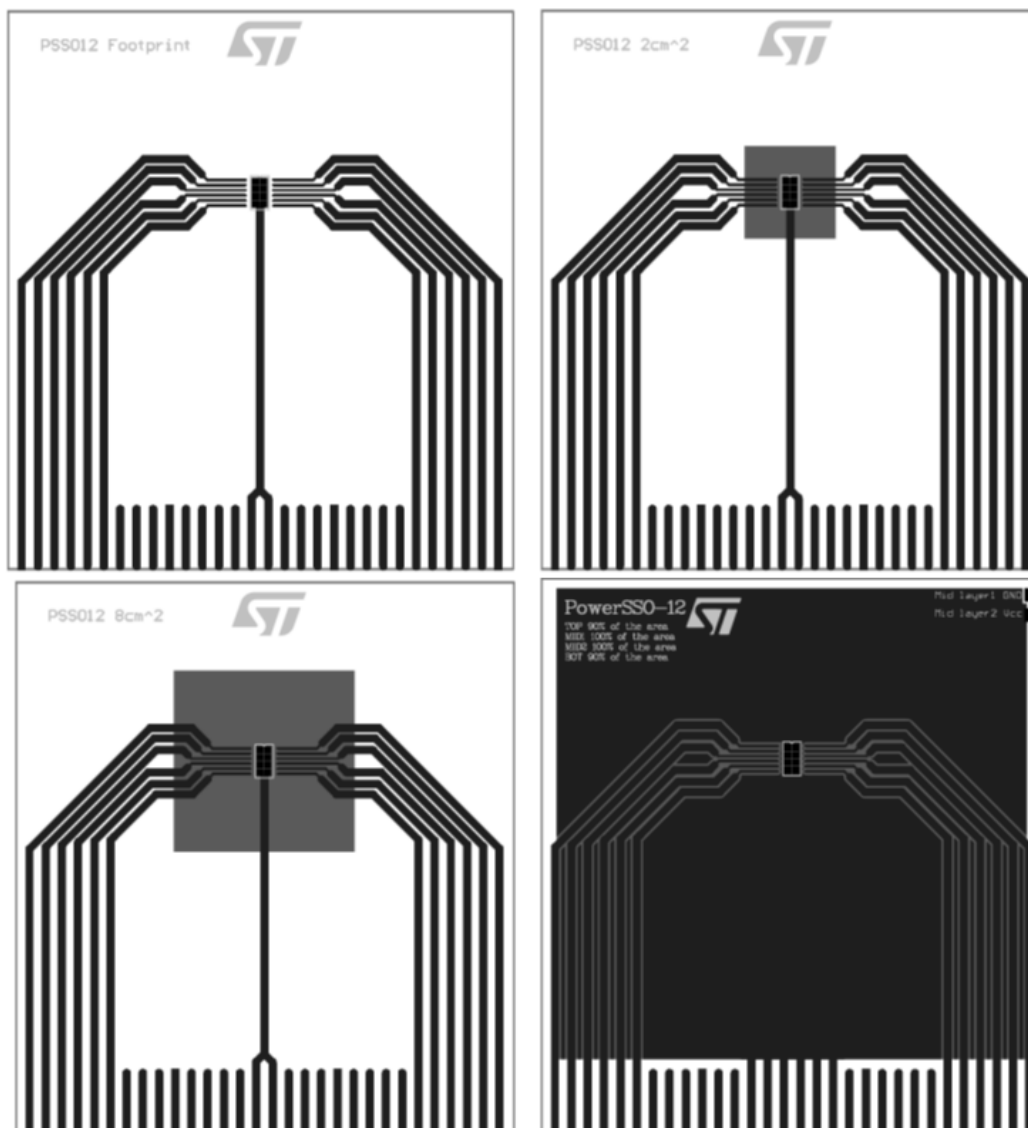
Figure 44. Typical application



## 6 Package and PCB thermal data

### 6.1 PowerSSO-12 thermal data

Figure 45. PowerSSO-12 PC board



**Note:** The values quoted are for PCB 77 mm x 86 mm x 1.6 mm, FR4, two and four layers; Cu thickness 0.070 mm (outer layers). Cu thickness 0.035 mm (inner layers), thermal via separation 1.2 mm, thermal via diameter 0.3 mm +/- 0.08 mm, Cu thickness on vias 0.025 mm, footprint dimension 2.2 mm x 2.9 mm.

Figure 46.  $R_{thj-amb}$  versus PCB copper area in open box free air condition

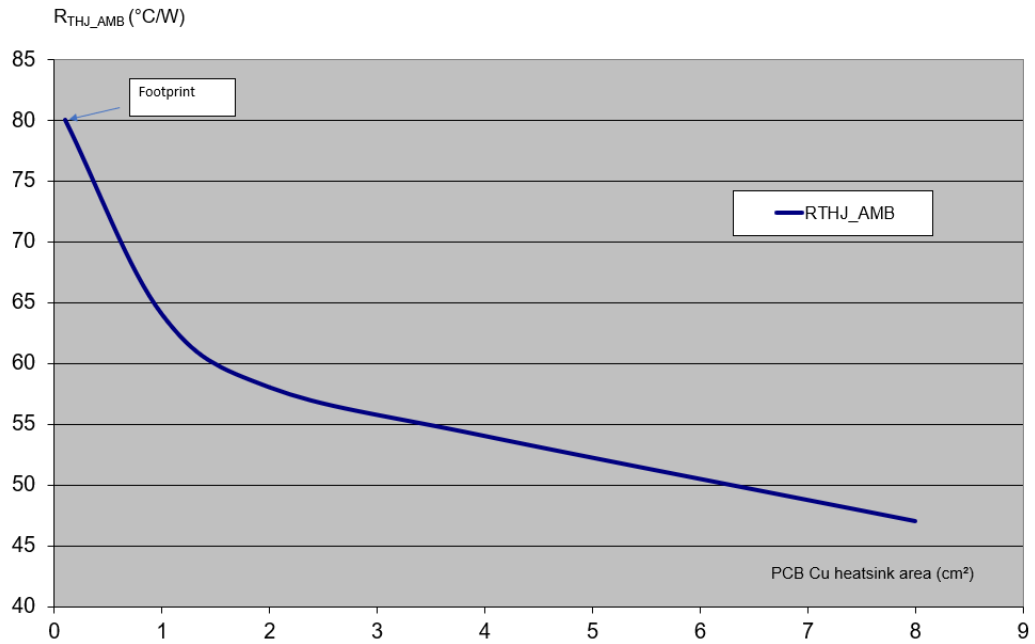
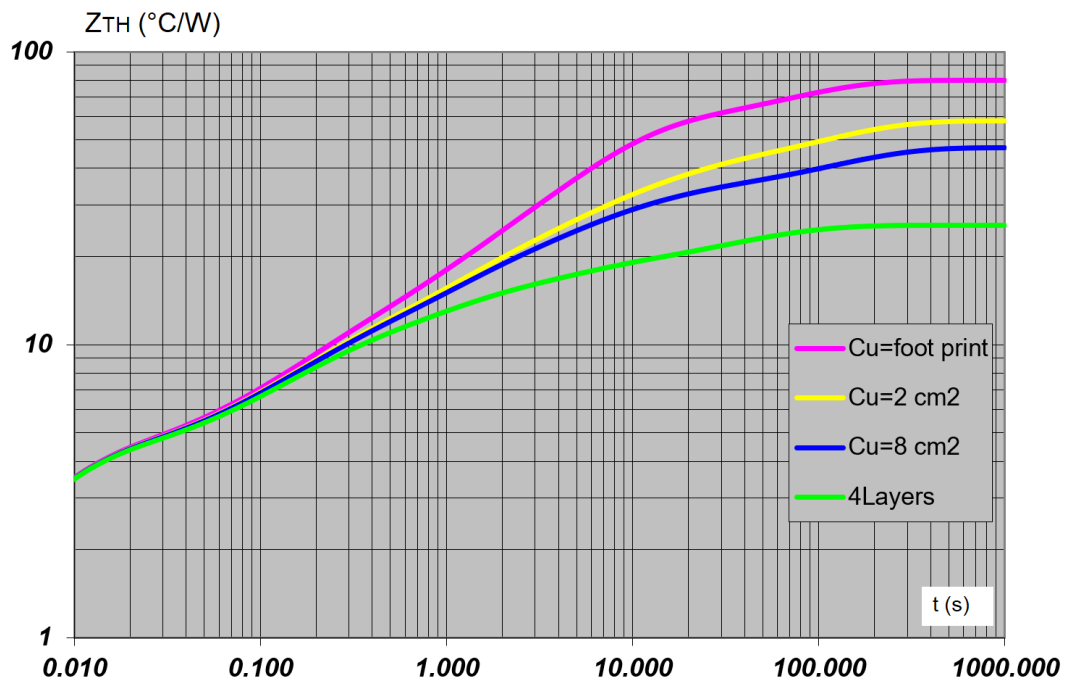


Figure 47. PowerSSO-12 thermal impedance junction ambient single pulse



Pulse calculation:

$$Z_{TH\delta} = R_{TH} \cdot \delta + Z_{THtp} (1 - \delta)$$

Where  $\delta = t_p/T$

Figure 48. Thermal fitting model of a  $V_{reg}$  in PowerSSO-12

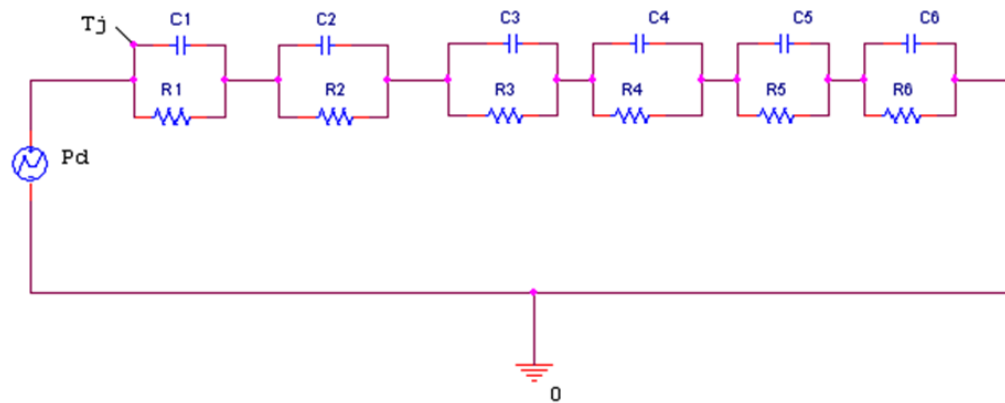


Table 16. PowerSSO-12 thermal parameter

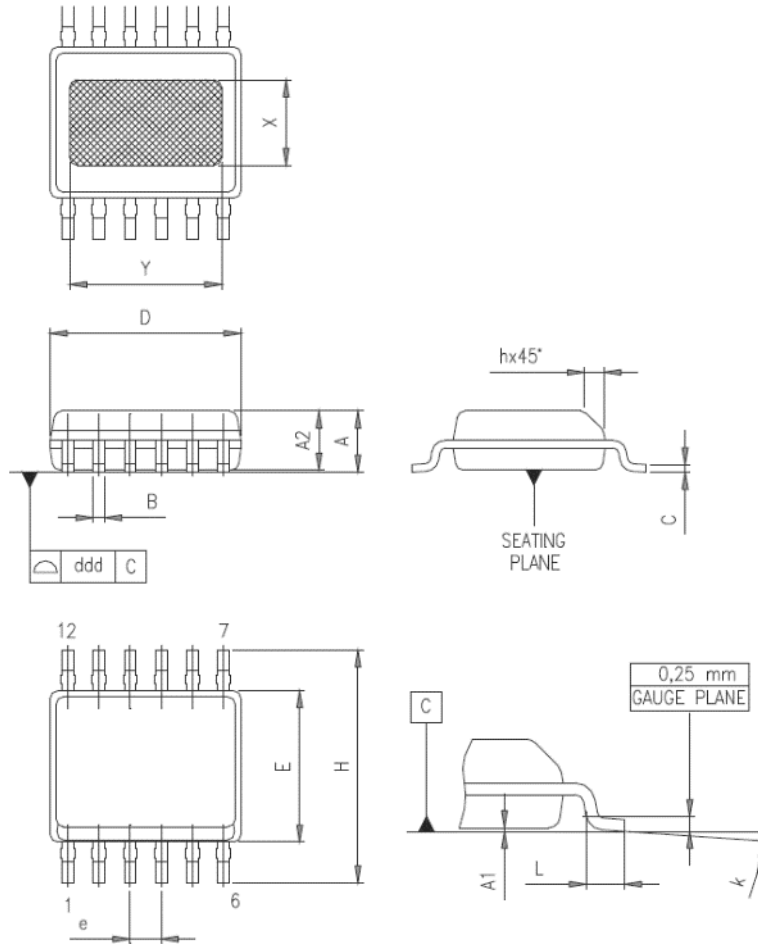
Area/island (cm <sup>2</sup> )	Footprint	2	8	4L
R1 (°C/W)	3.8			
R2 (°C/W)	4.2			
R3 (°C/W)	6	6	6	5
R4 (°C/W)	18	9	8	4.5
R5 (°C/W)	22	15	10	4
R6 (°C/W)	26	20	15	4
C1 (W.s/°C)	0.0015			
C2 (W.s/°C)	0.035			
C3 (W.s/°C)	0.15			
C4 (W.s/°C)	0.4	0.4	0.4	0.8
C5 (W.s/°C)	0.27	0.8	1	7
C6 (W.s/°C)	3	6	8	15

## 7 Package information

To meet environmental requirements, ST offers these devices in different grades of **ECOPACK** packages, depending on their level of environmental compliance. ECOPACK specifications, grade definitions, and product status are available at: [www.st.com](http://www.st.com). ECOPACK is an ST trademark.

### 7.1 PowerSSO-12 package information

Figure 49. PowerSSO-12 package dimensions

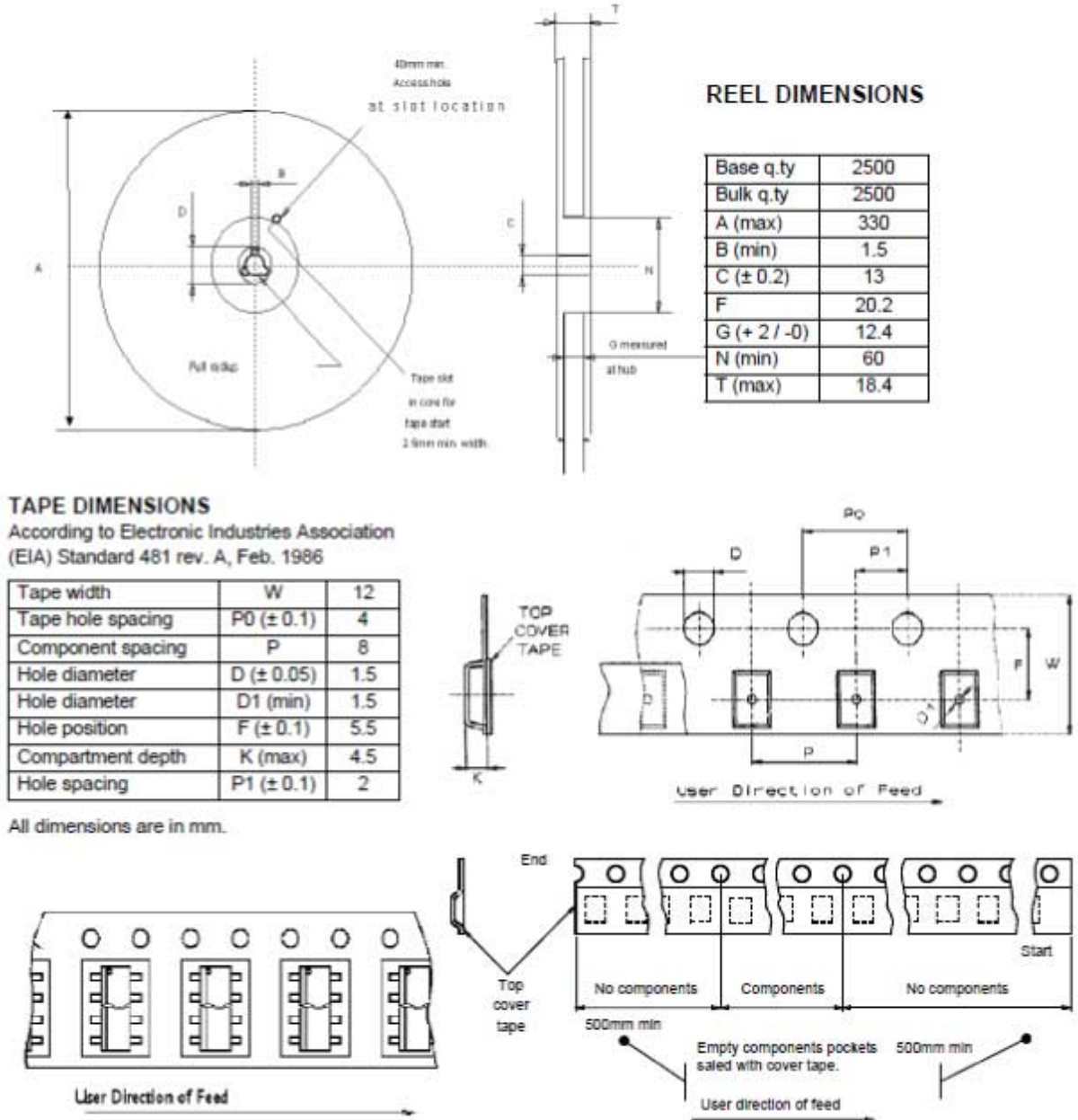


**Table 17. PowerSSO-12 package mechanical data**

Symbol	Millimeters		
	Min	Typ.	Max
A	1.250		1.700
A1	0.000		0.100
A2	1.100		1.600
b	0.230		0.410
c	0.190		0.250
D	4.800		5.000
E	3.800		4.000
e		0.800	
H	5.800		6.200
h	0.250		0.500
L	0.400		1.270
k	0°		8°
X	2.200		2.800
Y	2.900		3.500
ddd			0.100

## 7.2 PowerSSO-12 packaging information

Figure 50. PowerSSO-12 tape and reel shipment (suffix "TR")



## Revision history

**Table 18. Document revision history**

Date	Version	Changes
22-Dec-2022	1	Initial release
05-Mar-2026	2	Added Figure 28. Output noise voltage

## Contents

<b>1</b>	<b>Block diagram and pins description</b>	<b>3</b>
<b>2</b>	<b>Electrical specifications</b>	<b>5</b>
2.1	Absolute maximum ratings	5
2.2	Thermal data	6
2.2.1	Thermal resistance	6
2.2.2	Thermal protection	6
2.3	Electrical characteristics	7
2.4	Electrical characteristics curves	12
<b>3</b>	<b>Test circuit and waveforms plot</b>	<b>17</b>
3.1	Load regulation	17
<b>4</b>	<b>Application information</b>	<b>18</b>
4.1	Voltage regulator	19
4.2	Output current limitation	19
4.3	Output voltage selection	20
4.4	Enable	20
4.5	Reset	21
4.6	Autonomous watchdog	22
4.7	Thermal warning and thermal shutdown	23
4.8	Overvoltage detection by advanced thermal warning read-out	24
4.9	Fast output discharge	24
4.10	Undervoltage lockout UVLO	25
4.11	Support to ISO26262	26
<b>5</b>	<b>Application</b>	<b>27</b>
<b>6</b>	<b>Package and PCB thermal data</b>	<b>28</b>
6.1	PowerSSO-12 thermal data	28
<b>7</b>	<b>Package information</b>	<b>31</b>
7.1	PowerSSO-12 package information	31
7.2	PowerSSO-12 packaging information	33
	<b>Revision history</b>	<b>34</b>
	<b>List of tables</b>	<b>36</b>
	<b>List of figures</b>	<b>37</b>

## List of tables

<b>Table 1.</b>	Pins description . . . . .	4
<b>Table 2.</b>	Absolute maximum ratings . . . . .	5
<b>Table 3.</b>	Operation junction temperature . . . . .	6
<b>Table 4.</b>	Temperature threshold . . . . .	6
<b>Table 5.</b>	Electrical characteristics . . . . .	7
<b>Table 6.</b>	Fast output discharge . . . . .	9
<b>Table 7.</b>	Reset . . . . .	9
<b>Table 8.</b>	Watchdog . . . . .	10
<b>Table 9.</b>	Enable . . . . .	10
<b>Table 10.</b>	Output voltages selectors . . . . .	10
<b>Table 11.</b>	Thermal warning and protection . . . . .	11
<b>Table 12.</b>	Truth table . . . . .	20
<b>Table 13.</b>	Watchdog timer . . . . .	23
<b>Table 14.</b>	Safety requirement. . . . .	26
<b>Table 15.</b>	Implemented safety mechanism. . . . .	26
<b>Table 16.</b>	PowerSSO-12 thermal parameter . . . . .	30
<b>Table 17.</b>	PowerSSO-12 package mechanical data . . . . .	32
<b>Table 18.</b>	Document revision history . . . . .	34

## List of figures

<b>Figure 1.</b>	Functional block diagram of L99VR02J . . . . .	3
<b>Figure 2.</b>	Pins configuration . . . . .	4
<b>Figure 3.</b>	Output voltage vs $T_j$ . . . . .	12
<b>Figure 4.</b>	Output voltage vs $V_S$ . . . . .	12
<b>Figure 5.</b>	Drop voltage vs output current . . . . .	12
<b>Figure 6.</b>	Current consumption vs output current . . . . .	12
<b>Figure 7.</b>	Current consumption vs input voltage ( $I_o < 1$ mA) . . . . .	12
<b>Figure 8.</b>	Current consumption vs input voltage ( $I_o = 50$ mA) . . . . .	12
<b>Figure 9.</b>	Current consumption vs input voltage ( $I_o = 250$ mA) . . . . .	13
<b>Figure 10.</b>	Short-circuit current vs $T_j$ ( $I_{short}$ pin tied to GND) . . . . .	13
<b>Figure 11.</b>	Short-circuit current vs $T_j$ ( $I_{short}$ pin floating) . . . . .	13
<b>Figure 12.</b>	Short-circuit current vs input voltage . . . . .	13
<b>Figure 13.</b>	Output voltage vs enable voltage ( $V_O = 0.8$ V) . . . . .	13
<b>Figure 14.</b>	Output voltage vs enable voltage ( $V_O = 1.2$ V) . . . . .	13
<b>Figure 15.</b>	Output voltage vs enable voltage ( $V_O = 1.5$ V) . . . . .	14
<b>Figure 16.</b>	Output voltage vs enable voltage ( $V_O = 1.8$ V) . . . . .	14
<b>Figure 17.</b>	Output voltage vs enable voltage ( $V_O = 2.5$ V) . . . . .	14
<b>Figure 18.</b>	Output voltage vs enable voltage ( $V_O = 2.8$ V) . . . . .	14
<b>Figure 19.</b>	Output voltage vs enable voltage ( $V_O = 3.3$ V) . . . . .	14
<b>Figure 20.</b>	Output voltage vs enable voltage ( $V_O = 5$ V) . . . . .	14
<b>Figure 21.</b>	$V_{EN\_high}$ vs $T_j$ . . . . .	15
<b>Figure 22.</b>	$V_{EN\_low}$ vs $T_j$ . . . . .	15
<b>Figure 23.</b>	$V_{whth}$ vs $T_j$ . . . . .	15
<b>Figure 24.</b>	$V_{wth}$ vs $T_j$ . . . . .	15
<b>Figure 25.</b>	$I_{CWc}$ vs $T_j$ . . . . .	15
<b>Figure 26.</b>	$I_{CWd}$ vs $T_j$ . . . . .	15
<b>Figure 27.</b>	PSRR . . . . .	16
<b>Figure 28.</b>	Output noise voltage . . . . .	16
<b>Figure 29.</b>	Load regulation test circuit . . . . .	17
<b>Figure 30.</b>	Maximum load variation response ( $V_O = 5$ V) . . . . .	17
<b>Figure 31.</b>	Maximum load variation response ( $V_O = 3.3$ V) . . . . .	17
<b>Figure 32.</b>	Application schematic . . . . .	18
<b>Figure 33.</b>	Application schematic – Post regulation . . . . .	18
<b>Figure 34.</b>	Behavior of output current versus regulated voltage $V_O$ . . . . .	19
<b>Figure 35.</b>	$I_{short}$ versus $R_{sh}$ . . . . .	19
<b>Figure 36.</b>	Example of output voltage selection . . . . .	20
<b>Figure 37.</b>	Typical example of enable control . . . . .	21
<b>Figure 38.</b>	Reset timing diagram . . . . .	21
<b>Figure 39.</b>	Watchdog timing diagram . . . . .	22
<b>Figure 40.</b>	Thermal warning diagram . . . . .	23
<b>Figure 41.</b>	Square wave on TW pin generated during an overvoltage . . . . .	24
<b>Figure 42.</b>	Warning signal caused by overvoltage and thermal warning on TW pin . . . . .	24
<b>Figure 43.</b>	Undervoltage lock out on output voltage . . . . .	25
<b>Figure 44.</b>	Typical application . . . . .	27
<b>Figure 45.</b>	PowerSSO-12 PC board . . . . .	28
<b>Figure 46.</b>	$R_{thj-amb}$ versus PCB copper area in open box free air condition . . . . .	29
<b>Figure 47.</b>	PowerSSO-12 thermal impedance junction ambient single pulse . . . . .	29
<b>Figure 48.</b>	Thermal fitting model of a $V_{reg}$ in PowerSSO-12 . . . . .	30
<b>Figure 49.</b>	PowerSSO-12 package dimensions . . . . .	31
<b>Figure 50.</b>	PowerSSO-12 tape and reel shipment (suffix “TR”) . . . . .	33

**IMPORTANT NOTICE – READ CAREFULLY**

STMicroelectronics NV and its subsidiaries (“ST”) reserve the right to make changes, corrections, enhancements, modifications, and improvements to ST products and/or to this document at any time without notice.

In the event of any conflict between the provisions of this document and the provisions of any contractual arrangement in force between the purchasers and ST, the provisions of such contractual arrangement shall prevail.

The purchasers should obtain the latest relevant information on ST products before placing orders. ST products are sold pursuant to ST’s terms and conditions of sale in place at the time of order acknowledgment.

The purchasers are solely responsible for the choice, selection, and use of ST products and ST assumes no liability for application assistance or the design of the purchasers’ products.

No license, express or implied, to any intellectual property right is granted by ST herein.

Resale of ST products with provisions different from the information set forth herein shall void any warranty granted by ST for such product.

If the purchasers identify an ST product that meets their functional and performance requirements but that is not designated for the purchasers’ market segment, the purchasers shall contact ST for more information.

ST and the ST logo are trademarks of ST. For additional information about ST trademarks, refer to [www.st.com/trademarks](http://www.st.com/trademarks). All other product or service names are the property of their respective owners.

Information in this document supersedes and replaces information previously supplied in any prior versions of this document.

© 2026 STMicroelectronics – All rights reserved