

RTAX-S/SL and RTAX-DSP Radiation-Tolerant FPGAs

Radiation Performance

- SEU-Hardened Registers Eliminate the Need for Triple-Module Redundancy (TMR)
 - Immune to Single-Event Upsets (SEU) to $LET_{TH} > 37 \text{ MeV-cm}^2/\text{mg}$
 - SEU Rate $< 10^{-10}$ Errors/Bit-Day (worst case GEO)
- SRAM Upset Rate of $< 10^{-10}$ Errors/Bit-Day with Use of Error Detection and Correction (EDAC) IP (included) with Integrated SRAM Scrubber
 - Single-Bit Correction, Double-Bit Detection
 - Variable-Rate Background Refreshing
- Total Ionizing Dose Up to 300 krad (Si, Functional)
- Single-Event Latch-Up Immunity (SEL) to $LET_{TH} > 117 \text{ MeV-cm}^2/\text{mg}$
- TM1019 Test Data Available

Processing Flows

- B-Flow – MIL-STD-883B
- E-Flow – Extended Flow
- V-Flow – QML Class V per MIL-PRF-38535

Prototyping Options

- Commercial Axcelerator[®] Devices for Functional Verification (RTAX[™]-S/SL only)
- RTAX-S/SL PROTO and RTAX-DSP PROTO Devices with Same Functional and Timing Characteristics as Flight Unit in a Non-Hermetic Package
- Low-Priced Reprogrammable ProASIC^{®3} Option for Functional Verification (RTAX-S/SL only)

RTAX-SL Low Power Option

- Offers Up To 80% Saving of Static Current Compared to Standard RTAX-S Device at Worst-Case Conditions

Leading-Edge Performance

- High-Performance Embedded FIFOs
- 350+ MHz System Performance
- 500+ MHz Internal Performance
- 700 Mb/s LVDS Capable I/Os

Specifications

- Up to 4 Million Equivalent System Gates or 500 k Equivalent ASIC Gates
- Up to 20,160 SEU-Hardened Flip-Flops
- Up to 840 I/Os with SEU-Protected Input, Output, and Enable Registers
- Up to 540 kbits Embedded SRAM
- Manufactured on 0.15 μm CMOS Antifuse Process Technology, 7 Layers of Metal
- Electrostatic Discharge (ESD) is 2,000 V (HBM MIL-STD-883, TM3015)

Embedded Multiply/Accumulate Blocks (RTAX-DSP Only)

- Up to 120 Multiply/Accumulate Blocks
- Fully SEU- and SET-Hardened
- 125 MHz Performance throughout Military Temperature Range
- Flexible, Cascadable Accumulate Function

Features

- Single-Chip, Nonvolatile Solution
- 1.5 V Core Voltage for Low Power
- Flexible, Multi-Standard I/Os:
 - 1.5 V, 1.8 V, 2.5 V, 3.3 V Mixed Voltage Operation
 - Bank-Selectable I/Os – 8 Banks per Chip
 - Single-Ended I/O Standards: LVTTTL, LVCMOS, 3.3 V PCI
 - JTAG Boundary Scan Testing (as per IEEE 1149.1)
 - Differential I/O Standards: LVPECL and LVDS
 - Voltage-Referenced I/O Standards: GTL+, HSTL Class 1, SSTL2 Class 1 and 2, SSTL3 Class 1 and 2
 - Hot-Swap with Cold-Sparing Support (Except PCI)
- Embedded Memory with Variable Aspect Ratio:
 - Independent, Width-Configurable Read and Write Ports
 - Programmable Embedded FIFO Control Logic
 - ROM Emulation Capability
- Deterministic, User-Controllable Timing
- Unique In-System Diagnostic and Debug Capability

Table 1 • RTAX Family Product Profile

Device	RTAX250S/SL	RTAX1000S/SL	RTAX2000S/SL	RTAX4000S/SL	RTAX2000D/DL	RTAX4000D/DL
Capacity						
Equivalent System Gates	250,000	1,000,000	2,000,000	4,000,000	2,000,000	4,000,000
ASIC Gates	30,000	125,000	250,000	500,000	250,000	500,000
Modules						
Register (R-cells)	1,408	6,048	10,752	20,160	9,856	18,480
Combinatorial (C-cells)	2,816	12,096	21,504	40,320	19,712	36,960
Embedded RAM/FIFO (w/o EDAC)						
Core RAM Blocks	12	36	64	120	64	120
Core RAM Bits (K = 1,024)	54 k	162 k	288 k	540 k	288 k	540 k
Embedded Multiply/Accumulate Blocks	–	–	–	–	64	120
Clocks (segmentable)						
Hardwired	4	4	4	4	4	4
Routed	4	4	4	4	4	4
I/Os						
I/O Banks	8	8	8	8	8	8
User I/Os (maximum)	198	418	684	840	684	840
I/O Registers	744	1,548	2,052	2,520	2,052	2,520
Package						
CG/LG*	624	624	624, 1152	1272	1272	1272
CQ	208, 352	352	256, 352	352	352	352

Note: *The body size of the CG1272 and LG1272 packages used on the RTAX-DSP devices is slightly larger than the body size of the CG/LG1272 used on RTAX4000S/SL devices.

Ordering Information

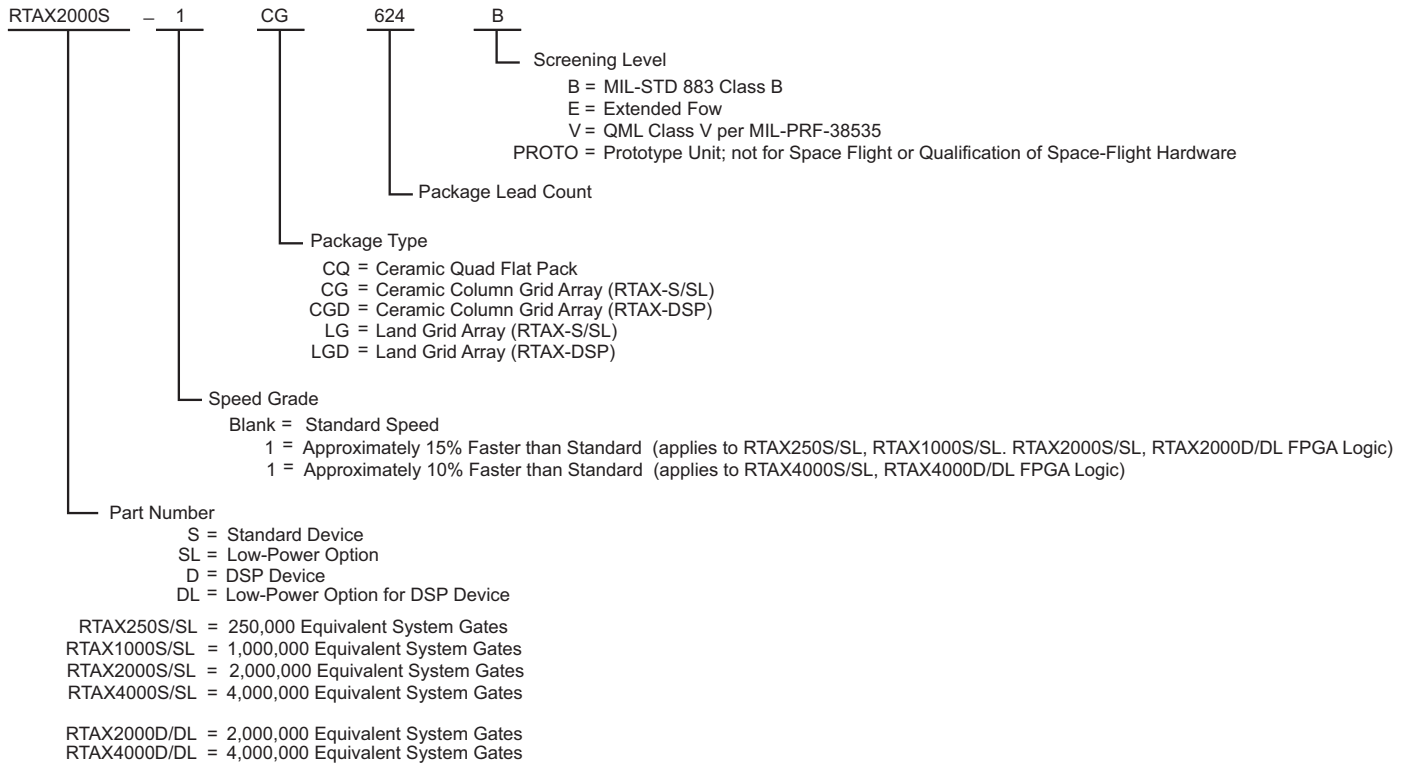

Note: All parts in Column Grid Array packages are now supplied with only Six Sigma solder columns.

Screening Levels

Package	RTAX250S/SL	RTAX1000S/SL	RTAX2000S/SL	RTAX4000S/SL	RTAX2000D/DL	RTAX4000D/DL
CQ208	B, E, V, PROTO	-	-	-	-	-
CQ256	-	-	B, E, V, PROTO	-	-	-
CQ352	B, E, V, PROTO	B, E, V, PROTO	B, E, V, PROTO	B, E, V, PROTO	B, E, V, PROTO	B, E, V, PROTO
CG624/LG624	B, E, V, PROTO	B, E, V, PROTO	B, E, V, PROTO	-	-	-
CG1152/LG1152	-	-	B, E, V, PROTO	-	-	-
CG1272/LG1272	-	-	-	B, E, V, PROTO	-	-
CGD1272/LGD1272	-	-	-	-	B, E, V, PROTO	B, E, V, PROTO

Note: B = MIL-STD-883 Class B
 E = Extended Flow
 V = QML Class V per MIL-PRF-38535
 PROTO = Prototype unit; not for space flight or qualification of space-flight hardware.

RTAX-S/SL and RTAX-DSP Device Status

RTAX-S/SL or RTAX-DSP Device	Status
RTAX250S	Production
RTAX250SL	Production
RTAX1000S	Production
RTAX1000SL	Production
RTAX2000S	Production
RTAX2000SL	Production
RTAX4000S	Production
RTAX4000SL	Production
RTAX2000D	Production
RTAX4000D	Production
RTAX2000DL	Production
RTAX4000DL	Production

Speed Grade and Temperature Grade Matrix

Temperature	RTAX250S/SL	RTAX1000S/SL	RTAX2000S/SL	RTAX4000S/SL	RTAX2000D/DL	RTAX4000D/DL
STD	✓	✓	✓	✓	✓	✓
-1	✓	✓	✓	✓	✓	✓

Notes:

1. Data applies to B, E, V, and PROTO flow devices.
2. Contact your Microsemi representative for availability.

Device Resources

User I/Os (Including Clock Buffers)						
Device	RTAX250S/SL	RTAX1000S/SL	RTAX2000S/SL	RTAX4000S/SL	RTAX2000D/DL	RTAX4000D/DL
CQ208	115	–	–	–	–	–
CQ256	–	–	136	–	–	–
CQ352	198	198	198 ¹	166	166 ¹	166
CG624/LG624	248	418	418	–	–	–
CG1152/LG1152	–	–	684	–	–	–
CG1272/LG1272	–	–	–	840	–	–
CGD1272/LGD1272	–	–	–	–	684	840 ²

CQ = Ceramic Quad Flat Pack, CG= Ceramic Column Grid Array, and LG = Land Grid Array

Notes:

1. RTAX2000S/SL and RTAX2000D/DL are not pin compatible in the CQ352 package type.
2. The package overhang for RTAX4000D/DL is slightly larger than RTAX4000S/SL, but they are pin compatible.

I/Os per Package

Package	Device	Single-Ended ¹	Adjacent Differential Pairs ²	Non-Adjacent Differential Pairs ³	Total I/Os
CQ208	RTAX250S	7	41	13	115
CQ256	RTAX2000S	4	66	0	136
CQ352	RTAX250S	2	98	0	198
	RTAX1000S	2	98	0	198
	RTAX2000S	2	98	0	198
	RTAX4000S	4	81	0	166
	RTAX2000D	4	81	0	166
	RTAX4000D	4	81	0	166
CG624 / LG624	RTAX250S	0	124	0	248
	RTAX1000S	68	170	5	418
	RTAX2000S	52	178	5	418
CG1152 / LG1152	RTAX2000S	0	342	0	684
CG1272 / LG1272	RTAX4000S	0	420	0	840
CGD1272 / LGD1272	RTAX2000D	0	342	0	684
	RTAX4000D	0	420	0	840

Notes:

1. Single-ended I/Os can implement only single ended I/O standards.
2. Adjacent differential pairs are pairs of I/Os that are physically adjacent and can implement differential I/O standards as well as single-ended I/O standards.
3. Non-adjacent differential pairs are pairs of I/Os that can implement differential I/O standards as well as single-ended I/O standards but are not physically adjacent.
4. The total number of I/Os is calculated by adding the single-ended I/Os, double the number of adjacent differential pairs, and double the number of non-adjacent differential pairs.

MIL-STD-883 Class B Product Flow

Table 2 • MIL-STD-883 Class B Product Flow for RTAX-S/SL and RTAX-DSP^{1, 2}

Step	Screen	Method	Requirement
1	Internal Visual	2010, Condition B	100%
2	Serialization		100%
3	Temperature Cycling	1010, Condition C, 10 cycles minimum	100%
4	Constant Acceleration	2001, Y1 Orientation Only Condition B for CQ256, CQ352, LG624, LG1152 Condition D for CQ208 Condition A ³ for LG1272, LGD1272, CQ352	100%
5	Particle Impact Noise Detection	2020, Condition A	100%
6	Seal (Fine & Gross Leak Test)	1014	100%
7	Pre-Burn-In Electrical Parameters	In accordance with applicable Microsemi device specification	100%
8	Dynamic Burn-In	1015, Condition D, 160 hours at 125°C or 80 hours at 150°C minimum	100%
9	Interim (Post-Burn-In) Electrical Parameters	In accordance with applicable Microsemi device specification	100%
10	Percent Defective Allowable (PDA) Calculation	5%	All Lots
11	Final Electrical Test ² a. Static Tests (1) 25°C (2) -55°C and +125°C b. Functional Tests (1) 25°C (2) -55°C and +125°C c. Switching Tests at 25°C	In accordance with applicable Microsemi device specification, which includes a, b, and c: 5005, Table 1, Subgroup 1 5005, Table 1, Subgroup 2, 3 5005, Table 1, Subgroup 7 5005, Table 1, Subgroup 8a, 8b 5005, Table 1, Subgroup 9	100%
12	External Visual	2009	100%

Notes:

1. For CCGA devices, all Assembly, Screening, and TCI testing are performed at LGA level. Only QA electrical and mechanical visual are performed after solder column attachment.
2. RTAX-S and RTAX-SL devices, as well as RTAX-D and RTAX-DL devices, have the same silicon and are distinguished by screening the ICCA current limits at 125°C final electrical test.
3. Condition A applies to RTAX4000S/SL, RTAX2000D/DL, and RTAX4000D/DL packages only.

Extended Flow

Table 3 • Extended Flow for RTAX-S/SL and RTAX-DSP^{1, 2, 3, 4}

Step	Screen	Method	Requirement
1	Destructive Bond Pull ⁵	2011, Condition D	Extended Sample
2	Internal Visual	2010, Condition A	100%
3	Serialization		100%
4	Temperature Cycling	1010, Condition C, 10 cycles minimum	100%
5	Constant Acceleration	2001, Y1 Orientation Only Condition B for CQ256, CQ352, LG624, LG1152 Condition D for CQ208 Condition A ⁶ for LG1272, LGD1272, CQ352	
6	Particle Impact Noise Detection	2020, Condition A	100%
7	Seal (Fine and Gross Leak Test)	1014	100%
8	Radiographic (X-Ray)	2012, One View (Y1 Orientation) Only	100%
9	Pre-Burn-In Electrical Parameters	In accordance with applicable Microsemi device specification	
10	Dynamic Burn-In	1015, Condition D, 240 hours at 125°C or 120 hours at 150°C minimum	100%
11	Interim (Post-Dynamic-Burn-In) Electrical Parameters	In accordance with applicable Microsemi device specification	100%
12	Static Burn-In	1015, Condition C, 72 hours at 150°C or 144 hours at 125°C minimum	100%
13	Interim (Post-Static-Burn-In) Electrical Parameters	In accordance with applicable Microsemi device specification	100%
14	Percent Defective Allowable (PDA) Calculation	5% Overall, 3% Functional Parameters at 25°C	All Lots
15	Final Electrical Test ⁴ a. Static Tests (1) 25°C (2) -55°C and +125°C b. Functional Tests (1) 25°C (2) -55°C and +125°C c. Switching Tests at 25°C	In accordance with applicable Microsemi device specification, which includes a, b, and c: 5005, Table 1, Subgroup 1 5005, Table 1, Subgroup 2, 3 5005, Table 1, Subgroup 7 5005, Table 1, Subgroup 8a, 8b 5005, Table 1, Subgroup 9	100%
16	Seal (Fine and Gross Leak Test)	1014	100%
17	External Visual	2009	100%

Notes:

1. Microsemi offers Extended Flow for users requiring additional screening beyond MIL-STD-883, Class B requirement. Microsemi is offering this Extended Flow incorporating the majority of the screening procedures as outlined in Method 5004 of MIL-STD-883, Class S.
2. The Quality Conformance Inspection (QCI) for Extended Flow devices still comply to MIL-STD-883, Class B requirement.
3. For CCGA devices, all Assembly/Screening/TCI testing are performed at LGA level. Only QA electrical and mechanical visual are performed after solder column attachment.
4. RTAX-S and RTAX-SL devices, as well as RTAX-D and RTAX-DL devices, have the same silicon and are distinguished by screening the ICCA current limits at 125°C final electrical test.
5. Requirement for 100% nondestructive bond pull per Method 2023 is substituted by an extensive destructive bond pull to Method 2011 Condition D on an extended sample basis.
6. Condition A applies to RTAX4000S/SL, RTAX2000D/DL, and RTAX4000D/DL packages only.

QML Class V MIL-PRF-38535 Flow

Table 4 • QML Class V MIL-PRF-38535 Flow for RTAX-S/SL and RTAX-DSP^{1,2}

Step	Screen	Method	Requirement
1	Destructive Bond Pull ³	2011, Condition D	Extended Sample
2	Internal Visual	2010, Condition A	100%
3	Serialization		100%
4	Temperature Cycling	1010, Condition C, 50 cycles minimum	100%
5	Constant Acceleration	2001, Y1 Orientation Only Condition B for CQ256, CQ352, LG624, LG1152 Condition D for CQ208 Condition A ⁴ for LG1272, LGD1272, CQ352	100%
6	Particle Impact Noise Detection	2020, Condition A	100%
7	Seal (Fine and Gross Leak Test)	1014	100%
8	Radiographic (X-Ray)	2012, One View (Y1 Orientation) Only	100%
9	Pre-Burn-In Electrical Parameters	In accordance with applicable Microsemi device specification	100%
10	Dynamic Burn-In	1015, Condition D, 240 hours at 125°C or 120 hours at 150°C minimum	100%
11	Interim (Post-Dynamic-Burn-In) Electrical Parameters	In accordance with applicable Microsemi device specification	100%
12	Static Burn-In	1015, Condition C, 72 hours at 150°C or 144 hours at 125°C minimum	100%
13	Interim (Post-Static-Burn-In) Electrical Parameters	In accordance with applicable Microsemi device specification	100%
14	Percent Defective Allowable (PDA) Calculation	5% Overall, 3% Functional Parameters at 25°C	All Lots
15	Final Electrical Test ² a. Static Tests (1) 25°C (2) -55°C and +125°C b. Functional Tests (1) 25°C (2) -55°C and +125°C c. Switching Tests at 25°C	In accordance with applicable Microsemi device specification, which includes a, b, and c: 5005, Table 1, Subgroup 1 5005, Table 1, Subgroup 2, 3 5005, Table 1, Subgroup 7 5005, Table 1, Subgroup 8a, 8b 5005, Table 1, Subgroup 9	100%
16	Seal (Fine and Gross Leak Test)	1014	100%
17	External Visual	2009	100%
18	Wafer Lot Specific Life Test (Group C)	MIL-PRF-38535, Appendix B, sec. B.4.2.c	All Wafer Lots

Notes:

- For CCGA devices, all Assembly/Screening/TCI testing are performed at LGA level. Only QA electrical and mechanical visual are performed after solder column attachment.
- RTAX-S and RTAX-SL devices, as well as RTAX-D and RTAX-DL devices, have the same silicon and are distinguished by screening the ICCA current limits at 125°C final electrical test.
- Requirement for 100% nondestructive bond pull per Method 2023 is substituted by an extensive destructive bond pull to Method 2011 Condition D on an extended sample basis.
- Condition A applies to RTAX4000S/SL, RTAX2000D/DL, and RTAX4000D/DL packages only.

Table of Contents

General Description

Device Architecture	1-1
Programmable Interconnect Element	1-1
Embedded Memory	1-5
I/O Logic	1-6
Mathblock Multiply-Accumulate Function (RTAX-DSP only)	1-7
RTAX-DSP Architecture	1-9
Routing	1-9
Global Resources	1-9
Design Environment	1-11
Programming	1-11
Low-Cost Prototyping Solutions	1-11
In-System Diagnostic and Debug Capabilities	1-12

Detailed Specifications

Operating Conditions	2-2
I/O Specifications	2-14
Module Specifications	2-83
Mathblock Timing Specification	2-93
Routing Specifications	2-97
Global Resources	2-102
Embedded Memory	2-111
Other Architectural Features	2-133
Programming	2-137

Package Pin Assignments

CQ208	3-1
CQ256	3-4
CQ352	3-8
CG624/LG624	3-34
CG1152/LG1152	3-53
CG1272/LG1272	3-65

Related Documents

Application Notes	4-1
User's Guides and Manuals	4-1
White Papers	4-1
Miscellaneous	4-1

Datasheet Information

List of Changes	5-1
Datasheet Categories	5-13
International Traffic in Arms Regulations (ITAR)	5-13
Safety Critical, Life Support, and High-Reliability Applications Policy	5-13

1 – General Description

RTAX-S/SL and RTAX-DSP FPGAs offer high performance at densities of up to four million equivalent system gates for space-based applications. Based upon the Microsemi commercial Axcelerator[®] family, RTAX-S/SL and RTAX-DSP have several system-level features such as embedded SRAM (with built-in FIFO control logic), segmentable clocks, chip-wide highway routing, and carry logic.

Featuring SEU-hardened flip-flops that offer the benefits of user-implemented Triple Module Redundancy (TMR) without the associated overhead, the RTAX-S/SL and RTAX-DSP families are the second generation of Microsemi's products for space applications. RTAX-S/SL and RTAX-DSP devices are manufactured using a 0.15 μm technology at a UMC facility in Taiwan. These devices offer levels of radiation survivability far in excess of typical CMOS devices.

Device Architecture

RTAX-S/SL architecture, derived from the highly-successful A54SX-A sea-of-modules architecture, has been designed for high performance and total logic module utilization (Figure 1-1). Unlike traditional FPGAs, the entire floor of the RTAX-S/SL or RTAX-DSP device is covered with a grid of logic modules, with virtually no chip area lost to interconnect elements or routing.

Programmable Interconnect Element

The RTAX-S/SL and RTAX-DSP families use a patented metal-to-metal antifuse programmable interconnect element that resides between the upper two layers of metal (Figure 1-2 on page 1-2). This completely eliminates the channels of routing and interconnect resources between logic modules (as implemented on traditional FPGAs) and enables the efficient sea-of-modules architecture. The antifuses are normally open circuit and, when programmed, form a permanent, passive, low-impedance connection, leading to the fastest signal propagation in the industry. In addition, the extremely small size of these interconnect elements gives the RTAX architecture abundant routing resources.

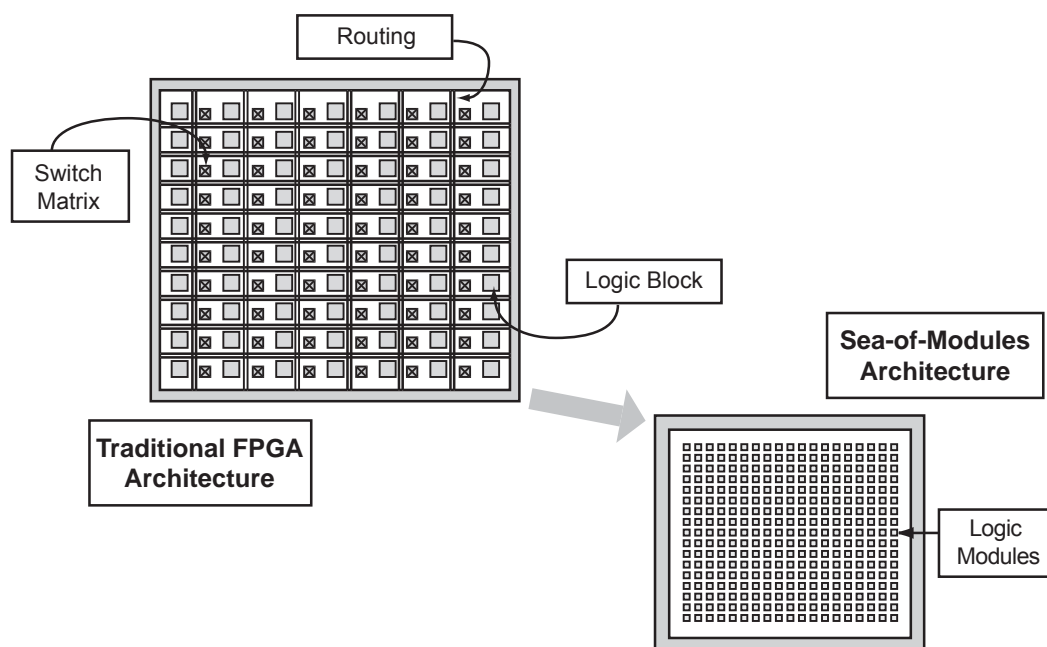

Figure 1-1 • Sea-of-Modules Comparison

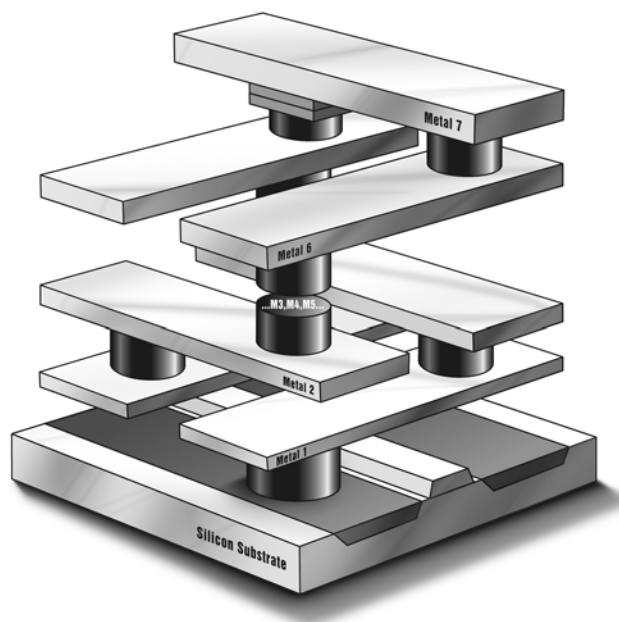

Figure 1-2 • RTAX Interconnect Elements

The very nature of nonvolatile antifuse technology provides excellent protection against design pirating and cloning (FuseLock[®] technology). Typical cloning attempts are impossible (even if the security fuse is left unprogrammed) as no bitstream or programming file is ever downloaded or stored in the device. Reverse engineering is virtually impossible due to the difficulty of trying to distinguish between programmed and unprogrammed antifuses and also due to the programming methodology of antifuse devices (see the "Security" section on page 2-136).

Microsemi's RTAX architecture provides two types of logic modules: the register cell (R-cell) and the combinatorial cell (C-cell). The RTAX C-cell can implement more than 4,000 combinatorial functions of up to five inputs (Figure 1-3 on page 1-3). The C-cell contains carry logic for even more efficient implementation of arithmetic functions. With its small size, the C-cell structure is extremely synthesis-friendly, simplifying the overall design as well as reducing design time.

While each SEU-hardened R-cell appears as a single D-Type flip-flop to the user, each is implemented in silicon using triple redundancy to achieve a LET threshold of greater than 60 MeV-mg/cm². Each TMR R-cell consists of three master-slave latch pairs, each with asynchronous self-correcting feedback paths. The output of each latch on the master or slave side votes with the outputs of the other two latches on that side. If one of the three latches is struck by an ion and starts to change state, the voting with the other two latches prevents that change from feeding back and permanently latching. Care was also taken in the layout to ensure that a single ion strike could not affect more than one latch (see the "R-Cell" section on page 2-87 for more details).

The R-cell contains a flip-flop featuring asynchronous clear, asynchronous preset, and active-low enable control signals (Figure 1-3 on page 1-3). The R-cell registers feature programmable clock polarity selectable on a register-by-register basis. This provides additional flexibility (e.g., easy mapping of dual-data-rate functions into the FPGA) while conserving valuable clock resources. The clock source for the R-cell can be chosen from the hardwired clocks, routed clocks, or internal logic.

Two C-cells, a single R-cell, and two Transmit (TX) and two Receive (RX) routing buffers form a Cluster, while two Clusters comprise a SuperCluster (Figure 1-4 on page 1-3). Each SuperCluster also contains an independent Buffer (B) module, which supports buffer insertion on high-fanout nets by the place-and-route tool, minimizing system delays while improving logic utilization.

The logic modules within the SuperCluster are arranged so that two combinatorial modules are side-by-side, giving a C-C-R - C-C-R pattern to the SuperCluster. This C-C-R pattern enables efficient implementation (minimum delay) of two-bit carry logic for improved arithmetic performance (Figure 1-5 on page 1-3).

The RTAX architecture is fully fracturable, meaning that if one or more of the logic modules in a SuperCluster are used by a particular signal path, the other logic modules are still available for use by other paths.

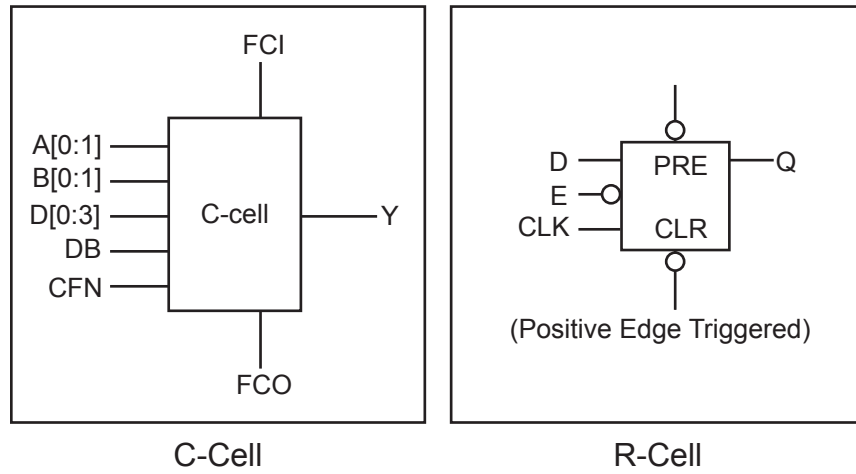

Figure 1-3 • RTAX C-Cell and R-Cell

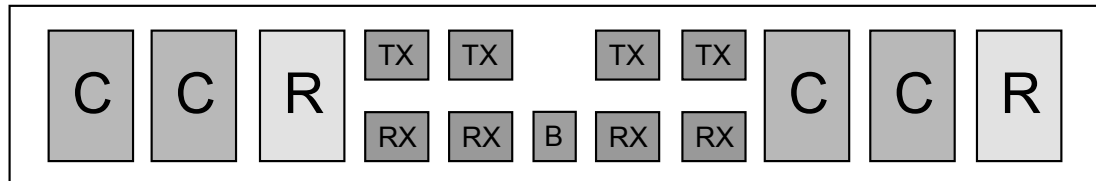

Figure 1-4 • RTAX SuperCluster

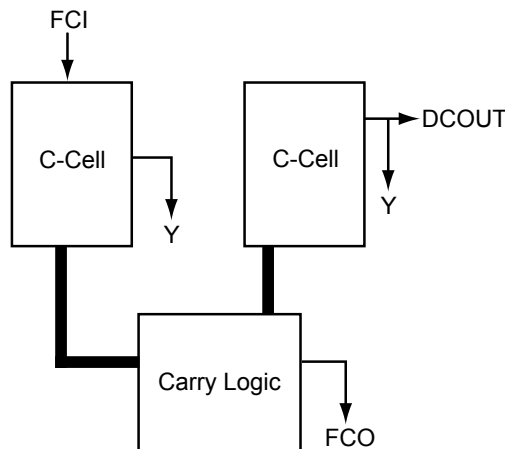

Figure 1-5 • RTAX Two-Bit Carry Logic

At the chip level, SuperClusters are organized into core tiles, which are arrayed to build up the full chip. For example, the RTAX1000S/SL is composed of a 3×3 array of nine core tiles. Surrounding the array of core tiles are blocks of I/O Clusters and the I/O bank ring (Table 1-1). Each core tile consists of an array of 336 SuperClusters and four SRAM blocks (176 SuperClusters and three SRAM blocks for the RTAX250S/SL). The SRAM blocks are arranged in a column on the west side of the tile (Figure 1-6).

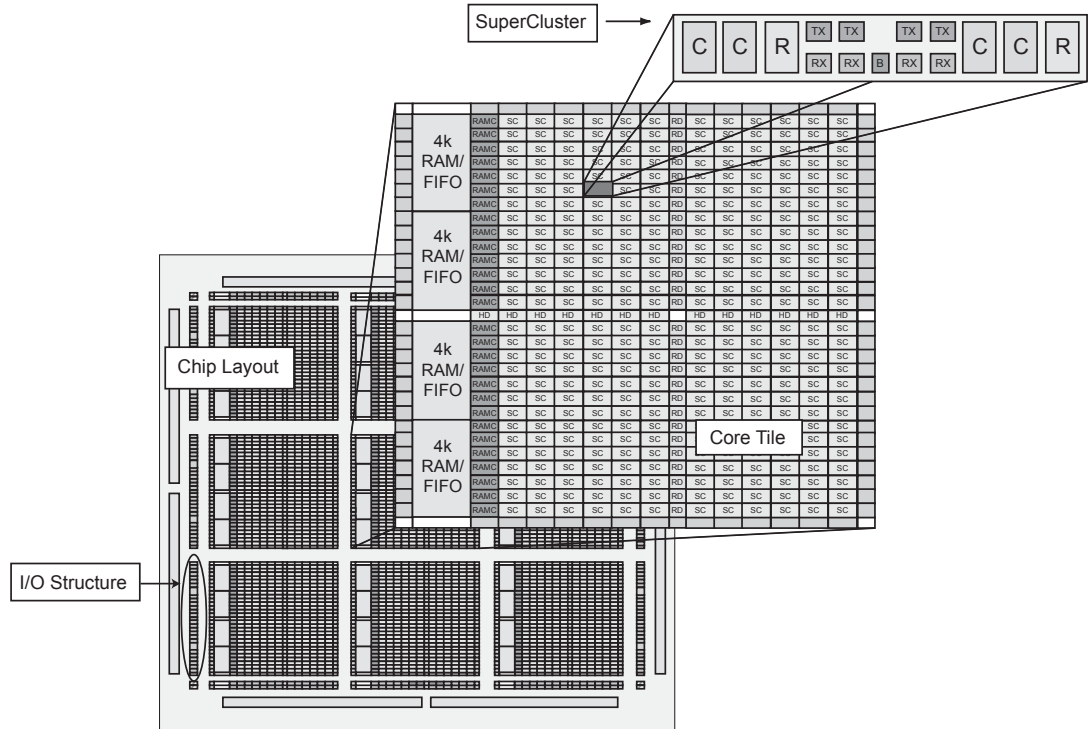

Figure 1-6 • RTAX Device Architecture (RTAX1000S/SL shown)

Table 1-1 • Number of Core Tiles per Device

Device	Number of Core Tiles
RTAX250S/SL	4 smaller tiles
RTAX1000S/SL	9 regular tiles
RTAX2000S/SL, RTAX2000D	16 regular tiles
RTAX4000S/SL, RTAX4000D	30 regular tiles

Embedded Memory

As mentioned earlier, each core tile has either three (in a smaller tile) or four (in the regular tile) embedded SRAM blocks along the west side, and each variable-aspect-ratio SRAM block is 4,608 bits in size. Available memory configurations are: 128x36, 256x18, 512x9, 1kx4, 2kx2 or 4kx1 bits. The individual blocks have separate read and write ports that can be configured with different bit widths on each port. For example, data can be written in by eight and read out by one.

In addition, every SRAM block has an embedded FIFO control unit. The control unit allows the SRAM block to be configured as a synchronous FIFO without using core logic modules. The FIFO width and depth are programmable. The FIFO also features programmable ALMOST-EMPTY (AEMPTY) and ALMOST-FULL (AFULL) flags in addition to the normal EMPTY and FULL flags. In addition to the flag logic, the embedded FIFO control unit also contains the counters necessary for the generation of the read and write address pointers as well as control circuitry to prevent metastability and erroneous operation. The embedded SRAM/FIFO blocks can be cascaded to create larger configurations.

The FIFO control unit was not implemented with SEU-hardened registers. Designs requiring high SEU tolerance should implement the FIFO control unit from hardened core logic.

SRAM structures are inherently susceptible to upsets caused by high-energy particles encountered in space. High-energy particles can cause an SRAM cell to change state, resulting in the loss or corruption of a valuable data bit. Also, the pipeline register in each of the memory blocks is not hardened and is susceptible to single event-upsets.

Microsemi has enhanced the SEU tolerance of the embedded SRAM within RTAX-S/SL and RTAX-DSP FPGAs by employing the use of two upset-mitigation techniques:

- Microsemi has developed Error Detection and Correction (EDAC) IP for use with RTAX-S/SL and RTAX-DSP. EDAC can be accomplished by the use of SmartGen-generated Error Correcting Codes (ECC) IP, which employs the use of shortened Hamming Codes
- A background memory-refresher, or scrubber circuitry, which has been embedded into the EDAC IP. The embedded scrubber circuitry periodically refreshes memory in the background to ensure that no data corruption occurs while the memory is not in use.

The use of EDAC IP combined with the embedded memory scrubber circuitry, gives RTAX-S/SL and RTAX-DSP FPGAs an SEU radiation performance level of better than 10^{-10} errors/bit-day. See the application note [Using EDAC RAM for RadTolerant RTAX-S/SL FPGAs and Axcelerator FPGAs](#).

I/O Logic

The RTAX-S/SL and RTAX-DSP families of FPGAs feature a flexible I/O structure, supporting a range of mixed voltages with its bank-selectable I/Os: 1.5 V, 1.8 V, 2.5 V, and 3.3 V. In all, RTAX-S/SL and RTAX-DSP FPGAs support at least 14 different I/O standards (single-ended, differential, voltage-referenced). The I/Os are organized into banks, with eight banks per device (two per side). The configuration of these banks determines the I/O standards supported (see the "User I/Os" section on page 2-16 for more information). All I/O standards are available in each bank.

Hot-swap and cold-sparing are supported for all I/O standards except PCI. Hot-swap (also called hot-plug, or hot-insertion) is the operation of hot-insertion or hot-removal of a card in a powered-up system. Cold-sparing (also called cold-swap) refers to the ability of a device to leave system data undisturbed when the system is powered up, while the component itself is powered down, or when power supplies are floating.

Each I/O module has an input register (InReg), an output register (OutReg), and an enable register (EnReg) (Figure 1-7). An I/O Cluster includes two I/O modules, four RX modules, two TX modules, and a buffer (B) module.

By design, all user flip-flops in the RTAX FPGAs are immune to SEUs including the following three registers located in every I/O cell buffer: InReg, OutReg, and EnReg.

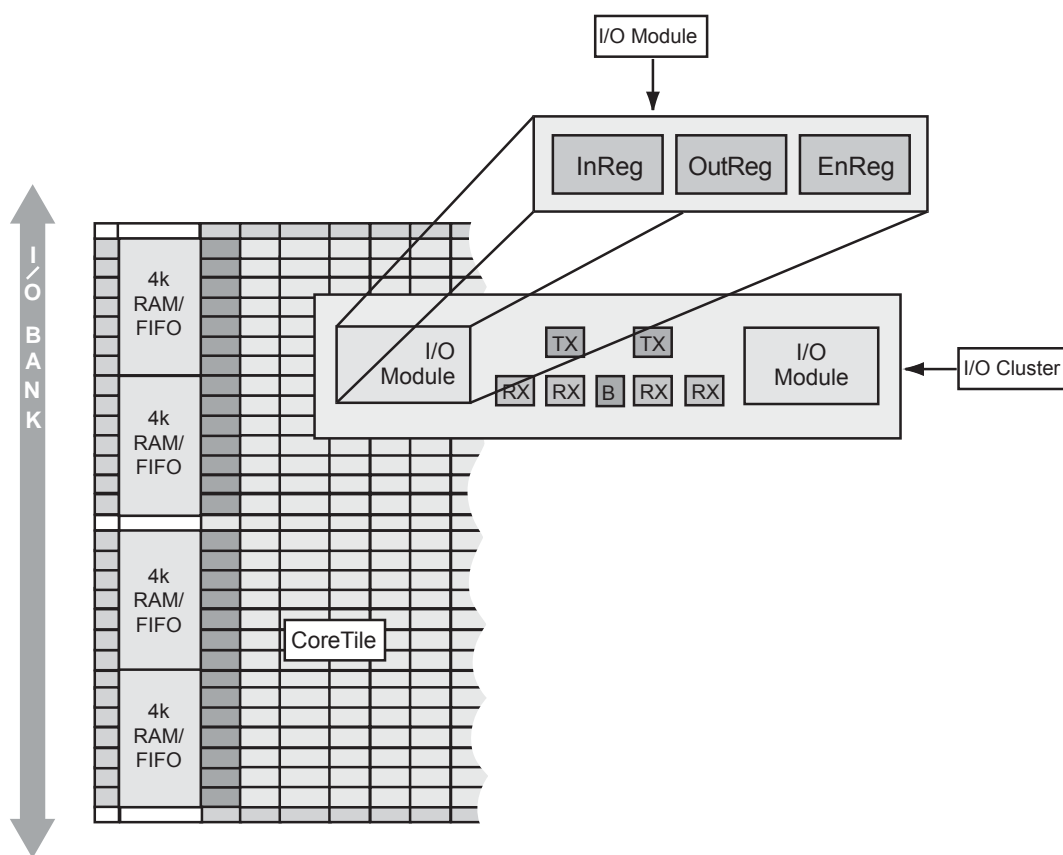

Figure 1-7 • I/O Cluster Arrangement

Mathblock Multiply-Accumulate Function (RTAX-DSP only)

The flexible elements of the RTAX-DSP Mathblocks enable easy integration into many different signal processing topologies, such as Fast Fourier Transforms, Inverse Fast Fourier Transforms, Finite Impulse Response Filters, Infinite Impulse Response Filters, and Discrete Cosine Transforms. The hardwired Mathblocks also enable acceleration of high precision single and double floating point multiplications. Figure 1-8 shows a basic functional diagram of a Mathblock.

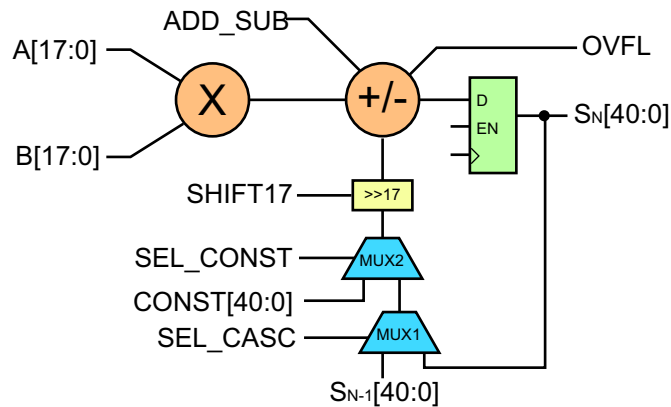

Figure 1-8 • RTAX-DSP Mathblock

The Mathblocks comprise the following elements:

1. Multiplier

The multiplier operates on two signed 18-bit factors, A[17:0] and B[17:0] (Figure 1-9). The multiplier produces a signed 36-bit output, which is provided as an input to the add/subtract function. The output of the multiplier can optionally bypass the add/subtract function.

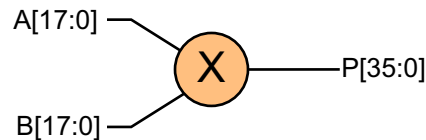

Figure 1-9 • RTAX-DSP Mathblock Multiplier Configured as Signed 18x18

The multiplier can be fractured to implement two instances of signed 9x9 multiplication (Figure 1-10).

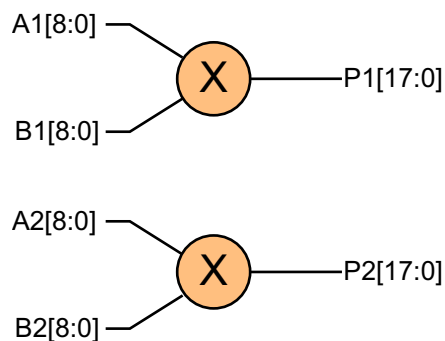

Figure 1-10 • Mathblock Configured with Two Independent Signed 9x9 multipliers

2. Adder/Subtractor plus MUX Control

- The adder/subtractor can perform the following functions:
 - Accumulate using feedback.
 - Create higher precision multipliers using the S_{N-1} input and the 17-bit shift function.
 - Create complex DSP functions, such as FIR filters, by cascading Mathblocks together using the S_{N-1} input.
 - The initial value of the accumulate function can be set using the value defined on the CONST bus.

Overflow or underflow of the add/subtract function is indicated by the OVFL output.

Figure 1-11 shows the Mathblock configured to perform multiply and accumulate functions. fabric resources can be used to extend the accumulate width.

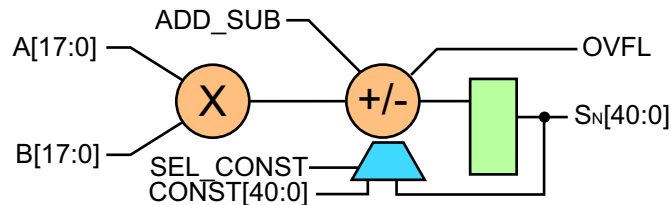

Figure 1-11 • Mathblock Configured to Perform Multiply and Accumulate Functions

3. Output Register

The output of the adder/subtractor block is presented to a 41-bit output register. The register has a clock input, an enable input, a set or reset input, and provides a 41-bit output $S_N[40:0]$ to the exterior of the Mathblock. Signals $S_N[40:0]$ are also fed back within the Mathblock to the accumulator multiplexer stack to enable various accumulation functions.

4. Cascading Mathblocks

Mathblocks may be cascaded together to form complex DSP structures such as FIR filters and FFTs. Figure 1-12 shows the configuration of Mathblocks cascaded together.

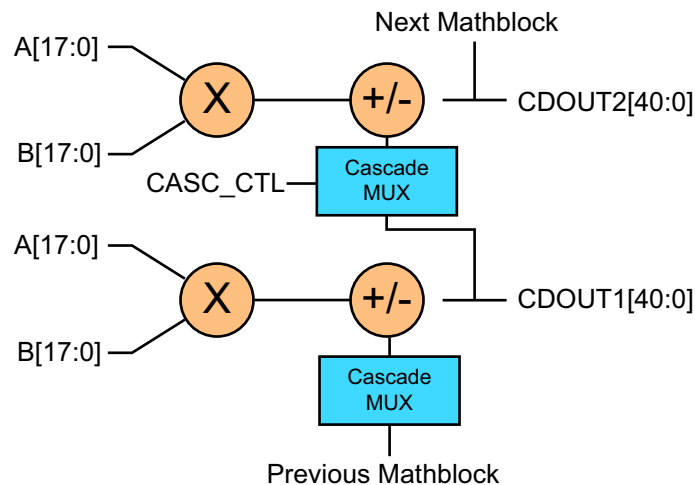

Figure 1-12 • Mathblocks Cascaded Together as Part of a Complex DSP Function

RTAX-DSP Architecture

The overall RTAX-DSP device architecture is shown in [Figure 1-13 on page 1-10](#). In each core tile, there are four Mathblocks, which are located adjacent to the SRAM/FIFO blocks. The Mathblocks are evenly distributed across the device, to help achieve uniform performance of DSP functions.

Routing

The RTAX hierarchical routing structure ties the logic modules, the embedded memory blocks, and the I/O modules together ([Figure 1-14 on page 1-10](#)). At the lowest level, in and between SuperClusters, there are three local routing structures: FastConnect, DirectConnect, and CarryConnect routing. DirectConnects provide the highest performance routing inside the SuperClusters by connecting a C-cell to the adjacent R-cell. DirectConnects do not require an antifuse to make the connection and achieve a signal propagation time of less than 0.1 ns.

FastConnects provide high-performance, horizontal routing inside the SuperCluster and vertical routing to the SuperCluster immediately below it. Only one programmable connection is used in a FastConnect path, delivering a maximum routing delay of 0.4 ns.

CarryConnects are used for routing carry logic between adjacent SuperClusters. They connect the carry-logic FCO output of one C-cell pair to the carry-logic FCI input of the C-cell pair of the SuperCluster below. CarryConnects do not require an antifuse to make the connection and achieve a signal propagation time of less than 0.1 ns.

The next level contains the core tile routing. Over the SuperClusters within a core tile, both vertical and horizontal tracks run across rows or columns, respectively. At the chip level, vertical and horizontal tracks extend across the full length of the device, both north-to-south and east-to-west. These tracks are composed of highway routing that extend the entire length of the device (segmented at core tile boundaries) as well as segmented routing of varying lengths.

Global Resources

Each family member has three types of global signals available to the designer: HCLK, CLK, and GCLR/GPSET. There are four hardwired clocks (HCLK) per device that can directly drive the clock input of each R-cell. Each of the four routed clocks (CLK) can drive the clock, clear, preset, or enable pin of an R-cell or any input of a C-cell ([Figure 1-3 on page 1-3](#)). Both these clocks can be segmented, allowing significantly more than eight clock domains to be implemented in the devices.

The RTAX1000S/SL, RTAX2000S/SL, RTAX4000S/SL, RTAX2000D, and RTAX4000D devices have 12 HCLK segments per tile and 28 RCLK segments per tile. The RTAX250S/SL has 8 HCLK segments per tile and 22 RCLK segments per tile.

Global clear (GCLR) and global preset (GPSET) drive the clear and preset inputs of each R-cell as well as each I/O Register on a chip-wide basis at power-up.

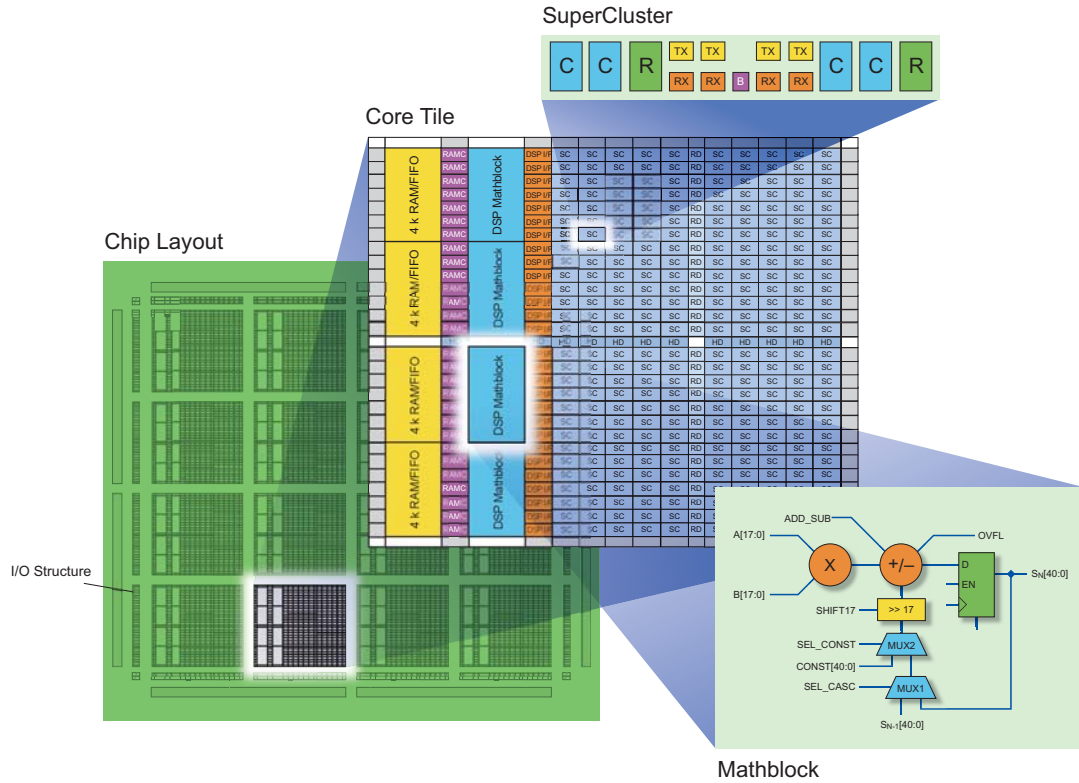

Figure 1-13 • RTAX-DSP Device Architecture Overview

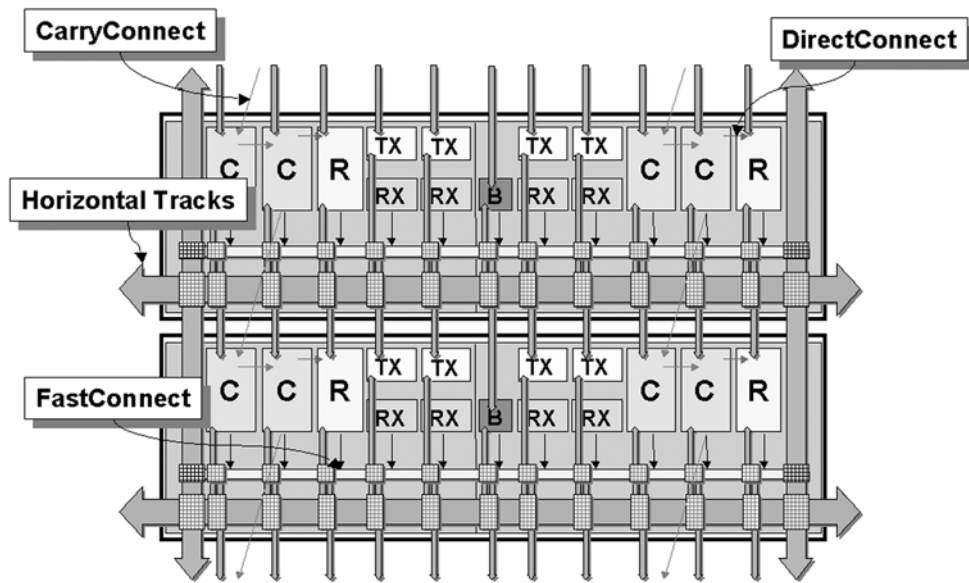

Figure 1-14 • RTAX Routing Structures

Design Environment

RTAX-S/SL and RTAX-DSP FPGAs are fully supported by both Microsemi Libero[®] Integrated Design Environment (IDE) and Designer FPGA development software. Microsemi Libero IDE is an integrated design manager that seamlessly integrates design tools while guiding the user through the design flow, managing all design and log files, and passing necessary design data among tools. Additionally, Libero IDE allows users to integrate both schematic and HDL synthesis into a single flow and verify the entire design in a single environment (see the [Libero IDE Flow](#) diagram located on the Microsemi SoC Products Group website). Libero IDE includes Synplify[®] AE from Synopsys, ViewDraw[®] AE from Mentor Graphics[®], ModelSim[®] HDL Simulator from Mentor Graphics, WaveFormer Lite[™] AE from SynaptiCAD[®], and Designer software from Microsemi.

Microsemi's Designer software is a place-and-route tool and provides a comprehensive suite of backend support tools for FPGA development. The Designer software includes the following:

- SmartTime – a world-class integrated static timing analyzer and constraints editor which support timing-driven place-and-route
- NetlistViewer – a design netlist schematic viewer
- ChipPlanner – a graphical floorplanner viewer and editor
- SmartPower – allows the designer to quickly estimate the power consumption of a design
- PinEditor – a graphical application for editing pin assignments and I/O attributes
- I/O Attribute Editor – displays all assigned and unassigned I/O macros and their attributes in a spreadsheet format

With the Designer software, a user can lock the design pins before layout while minimally impacting the results of place-and-route. Additionally, the Microsemi back-annotation flow is compatible with all the major simulators and the simulation results can be cross-probed with Silicon Explorer II, the Microsemi integrated verification and logic analysis tool. Another tool included in the Designer software is the SmartGen core generator, which easily creates popular and commonly used logic functions for implementation into your schematic or HDL design.

Microsemi Designer software is compatible with the most popular FPGA design entry and verification tools from EDA vendors, such as Mentor Graphics, Synplicity, Synopsys, and Cadence Design Systems. The Designer software is available for both the Windows and UNIX operating systems.

Programming

Programming support is provided through Silicon Sculptor 3, a single-site programmer driven via a PC-based GUI. Factory programming is available for high-volume production needs.

Low-Cost Prototyping Solutions

Since the enhanced radiation characteristics of radiation-tolerant devices are not required during the prototyping phase of the design, Microsemi has developed two prototyping options for RTAX-S/SL. For early design development and functional verification, Microsemi offers the commercial Axcelerator devices; for final flight design verification in hardware, Microsemi offers RTAX-S/SL PROTO devices that have the same form, fit, and function as the flight silicon. For RTAX-DSP devices, since there are no commercial equivalent devices with embedded Mathblocks, the preferred prototyping method is to use RTAX-DSP PROTO units.

Refer to Microsemi SoC Products Group website for more information on prototyping solutions: www.microsemi.com/soc/products/solutions/milaero/prototypingsolutions.aspx.

Prototyping with Axcelerator Units

The prototyping solution using the commercial Axcelerator devices consists of two parts:

- A well-documented design flow that allows the customer to target an RTAX-S/SL design to the equivalent commercial Axcelerator device
- A set of Microsemi Extender circuit boards that map the commercial device package to the appropriate RTAX-S package footprint

This methodology provides the user with a cost-effective solution while maintaining the short time-to-market associated with Microsemi FPGAs.

Prototyping with RTAX-S/SL and RTAX-DSP PROTO Units

The RTAX-S and RTAX-DSP PROTO units offer a prototyping solution that can be used for final timing verification of the flight design. The PROTO prototype units have the same timing attributes as the RTAX-S/SL and RTAX-DSP flight units.

Prototype units are offered in non-hermetic ceramic packages. The prototype units include "PROTO" in their part number, and "PROTO" is marked on devices to indicate that they are not intended for space flight. They also are not intended for applications which require the quality of space-flight units, such as qualification of space-flight hardware. RT-PROTO units offer no guarantee of hermeticity, and no MIL-STD-883B processing. At a minimum, users should plan on using class B level devices for all qualification activities.

The RT-PROTO units are electrically tested in a manner to guarantee their performance over the full military temperature range. The RT-PROTO units will also be offered in -1 or standard speed grades, so as to enable customers to validate the timing attributes of their space designs using actual flight silicon.

Prototyping with ProASIC3E Reprogrammable Units

Using Microsemi's ProASIC3E prototyping solution offers the unique advantage of reprogrammability, resulting in cost savings while providing faster functional verification of designs in prototype stage. This methodology employs a footprint compatible adaptor board and an EDIF netlist and pinout convertor for easy migration.

Please see the application note *Prototyping for RTAX-S and RTAX-SL Devices* for more details.

In-System Diagnostic and Debug Capabilities

The RTAX-S/SL family of FPGAs includes internal probe circuitry, allowing the designer to dynamically observe and analyze any signal inside the FPGA without disturbing normal device operation. Up to four individual signals can be brought out to dedicated probe pins (PRA/B/C/D) on the device. The probe circuitry is accessed and controlled via Silicon Explorer II (Figure 1-15), the Microsemi integrated verification and logic analysis tool that attaches to the serial port of a PC and communicates with the FPGA via the JTAG port (see the "Silicon Explorer II Probe Interface" section on page 2-136).

In addition, Microsemi offers a Configurable Logic Analyzer Module (CLAM), which allows a real-time verification and debug capability to be embedded into IP programmed into Microsemi FPGAs. CLAM allows signals from the inside of the IP core to be routed to the exterior of the chip for verification purposes.

Microsemi RTAX-S/SL and RTAX-DSP FPGAs offer enhanced capabilities beyond the successful RTSX-SU family of radiation-tolerant FPGAs, adding embedded RAM, FIFOs, and high-speed I/Os, and in the case of RTAX-DSP, adding embedded Mathblocks for enhanced signal processing. With the support of a suite of robust software tools, design engineers can incorporate high gate counts and fixed

pins into an RTAX-S/SL or RTAX-DSP design yet still achieve high performance and efficient device utilization in an SEU-hardened device.

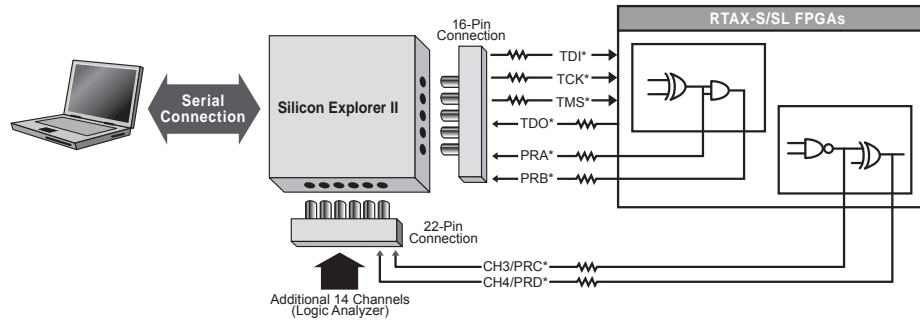

*Note: *Refer to the "Pin Descriptions" section on page 2-14 for more information.*

Figure 1-15 • Probe Setup RTAX-S/SL and RTAX-DSP

2 – Detailed Specifications

Table 2-1 • I/O Features Comparison

I/O Assignment	Clamp Diode	Hot Insertion / Cold Sparing	5 V Tolerance	Input Buffer	Output Buffer
3.3 V LVTTTL	Yes ¹	No	Yes ^{1,2}	Enabled/Disabled	
3.3 V PCI	Yes	No	Yes ²	Enabled/Disabled	
LVC MOS 2.5 V	No	Yes	No	Enabled/Disabled	
LVC MOS 1.8 V	No	Yes	No	Enabled/Disabled	
LVC MOS 1.5 V (JESD8-11)	No	Yes	No	Enabled/Disabled	
Voltage-Referenced Input Buffer	No	Yes	No	Enabled/Disabled	
Differential, LVDS/LVPECL, Input	No	Yes	No	Enabled	Disabled ³
Differential, LVDS/LVPECL, Output	No	Yes	No	Disabled	Enabled ⁴

Notes:

1. Default setting for the clamp diode is set to be PCI. The LVTTTL clamp diode is not enabled by default. To allow 5 V tolerance, the LVTTTL clamp diode needs to be enabled using settings in Designer. Hot-insertion and cold-sparing are not supported when the clamp diode is enabled. In other words, 5 V tolerance and hot-swapping/cold-sparing cannot coexist.
2. Can be implemented with an external resistor.
3. The OE input of the output buffer is automatically deasserted by Designer.
4. The OE input of the output buffer is automatically asserted by Designer.

5 V Tolerance

3.3 V PCI and 3.3 V LVTTTL (with clamp diode enabled) I/O standards directly allow 5 V tolerance. For example, the 3.3V PCI I/O standard provides an internal clamp diode between the input pad and the VCCI pad so that the voltage at the input pin is clamped below the absolute maximum input voltage of 4.1 V (Table 2-2 on page 2-2). An example of the input pad voltage level is shown in EQ 1:

$$V_{\text{input}} = V_{\text{CCI}} + V_{\text{diode}} = 3.3 \text{ V} + 0.7 \text{ V} = 4.0 \text{ V}$$

EQ 1

The internal VCCI clamp diode is only enabled while the device is powered on, so the voltage at the input will not be clamped if the VCCI or VCCA are powered off. An external series resistor (~100 Ω) is required between the input pin and the 5 V signal source to limit the current to less than 20 mA (Figure 2-1). The 100 Ω resistor was chosen to meet the input Tr/Tf requirement (Table 2-22 on page 2-26). The GND clamp diode is available for all I/O standards and always enabled.

5 V tolerance is not allowable for VCCI greater than 3.3 V or for input signals greater than 5.0 V.

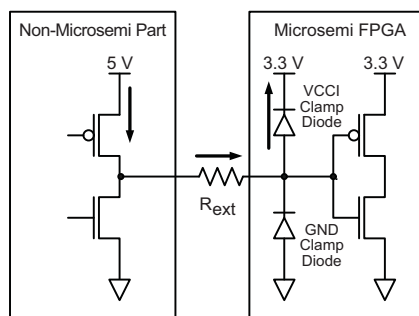

Figure 2-1 • Use of an External Resistor for 5 V Tolerance

Operating Conditions

Absolute Maximum Conditions

Stresses beyond those listed in Table 2-2 may cause permanent damage to the device. Exposure to Absolute Maximum rated conditions for extended periods may affect device reliability. Devices should not be operated outside the recommended operating conditions in Table 2-3.

Table 2-2 • Absolute Maximum Ratings

Symbol	Parameter	Limits	Units
T_J	Junction Temperature	-55 to +135	°C
VCCA	AC Core Supply Voltage ¹	-0.3 to 1.8	V
VCCA	DC Core Supply Voltage	-0.3 to 1.7	V
VCCI ²	DC I/O Supply Voltage	-0.3 to 3.75	V
VPUMP	Supply Voltage for External Pump	-0.3 to 3.75	V
VREF	DC I/O Reference Voltage	-0.3 to 3.75	V
VI	Input Voltage	-0.5 to 4.1	V
VO	Output Voltage	-0.5 to 3.75	V
TSTG	Storage Temperature	-60 to +150	°C
VCCDA ³	Supply Voltage for Differential I/Os	-0.3 to 3.75	V

Notes:

1. The AC transient VCCA limit is for radiation-induced transients less than 10 μ s duration and not intended for repetitive use. Core voltage spikes from a single event transient will not negatively affect the reliability of the device if, for this non-repetitive event, the transient does not exceed 1.8 V at any time and the total time that the transient exceeds 1.575 V does not exceed 10 μ s in duration.
2. The absolute maximum ratings of VCCI are applicable to all I/O standards supported by the device.
3. VCCDA must be greater than or equal to the highest VCCI voltage

Table 2-3 • RTAX-S/SL and RTAX-DSP Recommended Operating Conditions

Parameter Range	Military	Units
Junction Temperature (T_J)	-55 to +125	°C
Ambient Temperature (T_A) ¹	-55 to +125	°C
1.5 V Core Supply Voltage	1.425 to 1.575	V
1.5 V I/O Supply Voltage	1.425 to 1.575	V
1.8 V I/O Supply Voltage	1.71 to 1.89	V
2.5 V I/O Supply Voltage ²	2.375 to 2.625	V
3.3 V I/O Supply Voltage	3.0 to 3.6	V
2.5 V VCCDA I/O Supply Voltage (no differential I/O used) ²	2.375 to 2.625	V
3.3 V VCCDA I/O Supply Voltage (differential or voltage-referenced I/O used) ³	3.0 to 3.6	V
3.3 V VPUMP Supply Voltage	3.0 to 3.6	V

Notes:

1. Ambient temperature (T_A) is used for commercial and industrial grades; case temperature (T_C) is used for military grades.
2. Please see "VCCDA Supply Voltage" on page 2-14 more detail.

Overshoot/Undershoot Limits

For AC signals, the input signal may undershoot during transitions to -1.0 V for no longer than 10% of the period or 11 ns (whichever is smaller). Current during the transition must not exceed 95 mA.

For AC signals, the input signal may overshoot during transitions to $V_{CCI} + 1.0$ V for no longer than 10% of the period or 11 ns (whichever is smaller). Current during the transition must not exceed 95 mA.

Note: The above specification does not apply to the PCI standard. The RTAX-S/SL and RTAX-DSP PCI I/Os are compliant to the PCI standard including the PCI overshoot/undershoot specifications.

Power-Up/Down Sequence

VCCA, VCCI, and VCCDA can be powered up or powered down in any sequence. During power-up, all RTAX-S/SL and RTAX-DSP I/Os are tristated until they reach the state defined by the design. During power-down, all RTAX-S/SL and RTAX-DSP I/Os are tristated.

Refer to the *Board-Level Considerations for Power-Up and Power-Down of RTAX-S/SL FPGAs* application note for more information.

Calculating Power Dissipation

Table 2-4 • RTAX-S Standby Current

Device	Temperature	ICCA (mA)	ICCI (mA)	ICCD A (mA)	ICCDIFFA (mA)	I _{IH} , I _{IL} , I _{IOZ} (μ A) ¹
RTAX4000S	Typical 25°C	75	15	15	3.13	1
	125°C	600	60	20	3.7	5
RTAX2000S	Typical 25°C	50	10	7	2.96	1
	125°C	500	35	10	3.13	5
RTAX1000S	Typical 25°C	30	10	7	2.96	1
	125°C	450	35	10	3.13	5
RTAX250S	Typical 25°C	20	5	5	2.96	1
	125°C	250	20	10	3.13	5

Notes:

1. I_{IH}, I_{IL}, or I_{IOZ} values are measured with inputs at the same level as V_{CCI} for I_{IH} and GND for I_{IL} and I_{IOZ}.
2. Above values are maximum.
3. Values in the ICCDIFFA column refer to the current (in addition to ICCDA) flowing per pair through differential amplifiers only when using differential pairs or voltage references pins.

Table 2-5 • RTAX-SL Standby Current

Device	Temperature	ICCA (mA)	ICCI (mA)	ICCD A (mA)	ICCDIFFA (mA)	I _{IH} , I _{IL} , I _{IOZ} (μA) ¹
RTAX4000SL	Typical 25°C	40	15	15	3.13	1
	125°C	300	60	20	3.7	5
RTAX2000SL	Typical 25°C	30	10	7	3.13	1
	125°C	150	35	10	3.7	5
RTAX1000SL	Typical 25°C	20	10	7	3.13	1
	125°C	90	35	10	3.7	5
RTAX250SL	Typical 25°C	15	5	5	3.13	1
	125°C	60	20	10	3.7	5

Notes:

1. I_{IH}, I_{IL}, or I_{IOZ} values are measured with inputs at the same level as V_{CCI} for I_{IH} and GND for I_{IL} and I_{IOZ}.
2. Above values are maximum.
3. Values in the I_{CCDIFFA} column refer to the current (in addition to I_{CCDA}) flowing per pair through differential amplifiers only when using differential pairs or voltage references pins.

Table 2-6 • RTAX-DSP Standby Current

Device	Temperature	ICCA (mA)	ICCI (mA)	ICCD A (mA)	ICCDIFFA (mA)	I _{IH} , I _{IL} , I _{IOZ} (μA) ¹
RTAX4000D	Typical 25°C	75	15	15	3.13	1
	125°C	600	60	20	3.7	5
RTAX2000D	Typical 25°C	50	10	7	3.13	1
	125°C	500	35	10	3.7	5

Notes:

1. I_{IH}, I_{IL}, or I_{IOZ} values are measured with inputs at the same level as V_{CCI} for I_{IH} and GND for I_{IL} and I_{IOZ}.
2. Above values are maximum.
3. Values in the I_{CCDIFFA} column refer to the current (in addition to I_{CCDA}) flowing per pair through differential amplifiers only when using differential pairs or voltage references pins.

Table 2-7 • RTAX-DL Standby Current

Device	Temperature	ICCA (mA)	ICCI (mA)	ICCD A (mA)	ICCDIFFA (mA)	I _{IH} , I _{IL} , I _{IOZ} (μA) ¹
RTAX4000DL	Typical 25°C	40	15	15	3.13	1
	125°C	300	60	20	3.7	5
RTAX2000DL	Typical 25°C	30	10	7	3.13	1
	125°C	150	35	10	3.7	5

Notes:

1. I_{IH}, I_{IL}, or I_{IOZ} values are measured with inputs at the same level as V_{CCI} for I_{IH} and GND for I_{IL} and I_{IOZ}.
2. Above values are maximum.
3. Values in the I_{CCDIFFA} column refer to the current (in addition to I_{CCDA}) flowing per pair through differential amplifiers only when using differential pairs or voltage references pins.

Table 2-8 • Default Cload / VCCI

	CLOAD (pF)	VCCI (V)	PLOAD (μW/MHz)	P10 (μW/MHz)	PI/O (μW/MHz)*
Single-Ended without VREF					
LVC MOS – 15 (JESD8-11)	35	1.5	78.8	49.5	128.3
LVC MOS – 18	35	1.8	113.4	73.4	186.8
LVC MOS – 25	35	2.5	218.8	148.0	366.8
LV TTL 8 mA Low Slew	35	3.3	381.2	118.7	499.9
LV TTL 12 mA Low Slew	35	3.3	381.2	138.6	519.8
LV TTL 16 mA Low Slew	35	3.3	381.2	150.8	532.0
LV TTL 24 mA Low Slew	35	3.3	381.2	169.2	550.4
LV TTL 8 mA High Slew	35	3.3	381.2	130.3	511.5
LV TTL 12 mA High Slew	35	3.3	381.2	165.9	547.1
LV TTL 16 mA High Slew	35	3.3	381.2	225.1	606.3
LV TTL 24 mA High Slew	35	3.3	381.2	267.5	648.7
PCI	10	3.3	108.9	218.5	327.4
PCI-X	10	3.3	108.9	162.9	271.8
Single-Ended with VREF					
SSTL2-I	30	2.5	–	171.7	171.7
SSTL2-II	30	2.5	–	148.3	148.3
SSTL3-I	30	3.3	–	327.8	327.8
SSTL3-II	30	3.3	–	288.9	288.9
HSTL-I	20	1.5	–	41.4	41.4
GTLP – 33	10	3.3	–	68.5	68.5
Differential					
LVPECL – 33	N/A	3.3	–	260.6	260.6
LVDS – 25	N/A	2.5	–	145.8	145.8

Note: $*P_{I/O} = P_{10} + C_{load} * VCCI^2$

Table 2-9 • Different Components Contributing to the Total Power Consumption in RTAX-S/SL/DSP Devices

Sym.	Power Component	Device-Specific Value (in $\mu\text{W}/\text{MHz}$)					
		RTAX250S/SL	RTAX1000S/SL	RTAX2000S/SL	RTAX4000S/SL	RTAX2000D/DL	RTAX4000D/DL
P1	Core tile HCLK power component	85.8	227.5	378.0	700	378.0	700.0
P2	R-cell power component	0.6	0.6	0.6	0.6	0.6	0.6
P3	HCLK signal power dissipation	7.7	23.2	31.0	50.0	31.0	50.0
P4	Core tile RCLK power component	85.8	227.5	378.0	700	378.0	700.0
P5	R-cell power component	0.9	0.9	0.9	0.9	0.9	0.9
P6	RCLK signal power dissipation	8.6	25.7	34.3	55.0	34.3	55.0
P7	Power dissipation due to the switching activity on the R-cell	1.6	1.6	1.6	1.6	1.6	1.6
P8	Power dissipation due to the switching activity on the C-cell	1.4	1.4	1.4	1.4	1.4	1.4
P9	Power component associated with input voltage	10.0	10.0	10.0	10.0	10.0	10.
P10	Power component associated with output voltage	See Table 2-4 and Table 2-5 on page 2-4 for per pin contribution.					
P11	Power component associated with the read operation in the RAM block	25.0	25.0	25.0	25.0	25.0	25.0
P12	Power component associated with the write operation in the RAM block	30.0	30.0	30.0	30.0	30.0	30.0
P13	Math Block multiplier only	–	–	–	–	9	9
P14	Math Block multiplier with adder	–	–	–	–	15	15
P15	Math Block multiplier only – SIMD	–	–	–	–	5.9	5.9
P16	Math Block multiplier with adder – SIMD	–	–	–	–	10.2	10.2
P17	Math Block clock contribution	–	–	–	–	59.26	59.26

$$P_{\text{total}} = P_{\text{dc}} + P_{\text{ac}}$$

$$P_{\text{dc}} = I_{\text{CCA}} * V_{\text{CCA}} + I_{\text{CCI}} * V_{\text{CCI}} + I_{\text{CCDA}} * V_{\text{CCDA}} + I_{\text{CCDIFFA}} * V_{\text{CCDA}} * N_{\text{b_da_pairs}}$$

$$P_{\text{ac}} = P_{\text{HCLK}} + P_{\text{CLK}} + P_{\text{R-cells}} + P_{\text{C-cells}} + P_{\text{inputs}} + P_{\text{outputs}} + P_{\text{memory}} + P_{\text{mathblock}}$$

$$N_{\text{b_da_pairs}} = \text{number of differential pairs or voltage referenced pins used}$$

$$P_{\text{HCLK}} = (P1 + P2 * s + P3 * \sqrt{s}) * F_s$$

$$s = \text{number of R-cells clocked by this clock}$$

$$F_s = \text{clock frequency}$$

$$P_{\text{CLK}} = (P4 + P5 * s + P6 * \sqrt{s}) * F_s$$

$$s = \text{number of R-cells clocked by this clock}$$

$$F_s = \text{clock frequency}$$

$$P_{\text{R-cells}} = P7 * m_s * F_s$$

$$m_s = \text{number of R-cells switching at each } F_s \text{ cycle}$$

$$F_s = \text{clock frequency}$$

$$P_{\text{C-cells}} = P8 * m_c * F_s$$

$$m_c = \text{number of C-cells switching at each } F_s \text{ cycle}$$

$$F_s = \text{clock frequency}$$

$$P_{\text{inputs}} = P9 * p_i * F_{p_i}$$

$$p_i = \text{number of inputs}$$

$$F_{p_i} = \text{average input frequency}$$

$$P_{\text{outputs}} = (P10 + C_{\text{load}} * V_{\text{CCI}}^2) * p_o * F_{p_o}$$

$$C_{\text{load}} = \text{output load (technology dependent)}$$

$$V_{\text{CCI}} = \text{output voltage (technology dependent)}$$

$$p_o = \text{number of outputs}$$

$$F_{p_o} = \text{average output frequency}$$

$$P_{\text{memory}} = P11 * N_{\text{block}} * F_{\text{RCLK}} + P12 * N_{\text{block}} * F_{\text{WCLK}}$$

$$N_{\text{block}} = \text{number of RAM/FIFO blocks (1 block = 4 k)}$$

$$F_{\text{RCLK}} = \text{read-clock frequency of the memory}$$

$$F_{\text{WCLK}} = \text{write-clock frequency of the memory}$$

$$P_{\text{MathBlock}} = N_{\text{block}} * F_{\text{CLK}} * (P17 \text{ (if pipe)} + P13) \text{ when SIMD = No and Add = No}$$

$$P_{\text{MathBlock}} = N_{\text{block}} * F_{\text{CLK}} * (P17 \text{ (if pipe)} + P14) \text{ when SIMD = No and Add = Yes}$$

$$P_{\text{MathBlock}} = N_{\text{block}} * F_{\text{CLK}} * (P17 \text{ (if pipe)} + P15) \text{ when SIMD = Yes and Add = No}$$

$$P_{\text{MathBlock}} = N_{\text{block}} * F_{\text{CLK}} * (P17 \text{ (if pipe)} + P16) \text{ when SIMD = Yes and Add = Yes}$$

$$N_{\text{block}} = \text{Number of math blocks}$$

$$F_{\text{CLK}} = \text{Clock frequency}$$

$$\text{SIMD} = \text{Mode of the math block: fractured (SIMD = Yes) or normal (SIMD = No)}$$

$$\text{Add} = \text{Configuration of the math block: multiply only (Add = No) or multiply-accumulate (Add = Yes)}$$

$$\text{pipe} = P17 \text{ should be added if the internal registers of the math block are used.}$$

Power Estimation Example

This example employs an RTAX1000S/SL shift-register design with 1,080 R-cells, one C-cell, one reset input, and one output. This design also uses a single clock (HCLK) at 100 MHz and is operated under room temperature.

$ms = 1,080$ (in a shift register 100% of R-cells are toggling at each clock cycle)

$$F_s = 100 \text{ MHz}$$

$$s = 1,080$$

$$\Rightarrow P_{HCLK} = (P1 + P2 * s + P3 * \text{sqrt}[s]) * F_s = 163.8 \text{ mW}$$

and $F_s = 100 \text{ MHz}$

$$\Rightarrow P_{R\text{-cells}} = P7 * ms * F_s = 172.8 \text{ mW}$$

$$mc = 1 \text{ (1 C-cell in this design)}$$

$$\text{and } F_s = 100 \text{ MHz}$$

$$\Rightarrow P_{C\text{-cells}} = P8 * mc * F_s = 0.14 \text{ mW}$$

$$F_{pi} \sim 0 \text{ MHz}$$

$$\text{and } pi = 1 \text{ (1 reset input } \Rightarrow \text{ this is why } F_{pi} = 0)$$

$$\Rightarrow P_{inputs} = P9 * pi * F_{pi} = 0 \text{ mW}$$

$$F_{po} = 50 \text{ MHz}$$

$$C_{load} = 35 \text{ pF}$$

$$V_{CCI} = 3.3 \text{ V}$$

$$\text{and } po = 1$$

$$\Rightarrow P_{outputs} = (P10 + C_{load} * V_{CCI}^2) * po * F_{po} = 23.6 \text{ mW}$$

No RAM/FIFO in this shift-register

$$\Rightarrow P_{memory} = 0 \text{ mW}$$

$$P_{ac} = P_{HCLK} + P_{CLK} + P_{R\text{-cells}} + P_{C\text{-cells}} + P_{inputs} + P_{outputs} + P_{memory} = 360.4 \text{ mW}$$

$$P_{dc} = I_{CCA} * V_{CCA} + I_{CCI} * V_{CCI} + I_{CCDA} * V_{CCDA} + I_{CCDIFFA} * V_{CCDA} * N_{b_da_pairs} = 101.1 \text{ mW}$$

$$P_{total} = P_{dc} + P_{ac} = 360.4 \text{ mW} + 101.1 \text{ mW} = 461.5 \text{ mW}$$

Thermal Characteristics

The temperature variable in Microsemi Designer software refers to the junction temperature, not the ambient, case or board temperature. This is an important distinction because dynamic and static power consumption causes the chip's junction temperature to be higher than the ambient, case or board temperature. EQ 2, EQ 3, and EQ 4 show the relationship between thermal resistance, temperature, and power.

$$\theta_{ja} = \frac{T_j - T_a}{P} \quad \text{EQ 2}$$

$$\theta_{jc} = \frac{T_j - T_c}{P} \quad \text{EQ 3}$$

$$\theta_{jb} = \frac{T_j - T_b}{P} \quad \text{EQ 4}$$

Where:

- θ_{ja} = Thermal resistance from junction to air
- θ_{jc} = Thermal resistance from junction to case
- θ_{jb} = Thermal resistance from junction to board
- T_j = Junction Temperature
- T_a = Ambient Temperature
- T_c = Case Temperature
- T_b = Board Temperature
- P = Power

Table 2-10 • Package Thermal Characteristics

Product	Package Type	θ_{ja}	θ_{jc}	θ_{jb}	Units
RTAX250S/SL	CQ208	19.9	0.8	N/A	C/W
	CQ352	16.8	0.7	N/A	C/W
	CG624	13.7	TBD	TBD	C/W
RTAX1000S/SL	CQ352	13.3	0.4	N/A	C/W
	CG624	10.8	5.6	4.5	C/W
RTAX2000S/SL	CQ256	15.8	0.25	N/A	C/W
	CQ352	12.3	0.2	N/A	C/W
	CG624	9.7	4.3	3.5	C/W
	CG1152	9.0	2.0	2.6	C/W
RTAX4000S/SL	CQ352	12.3	0.2	N/A	C/W
	CG1272	8.0	2.0	2.2	C/W
RTAX2000D/DL	CQ352	TBD	TBD	N/A	C/W
	CGD1272	TBD	TBD	TBD	C/W
RTAX4000D/DL	CQ352	TBD	0.17	N/A	C/W
	CGD1272	TBD	TBD	TBD	C/W

Notes:

1. θ_{ja} are estimated at still air.
2. θ_{jc} for CQFP packages refers to the thermal resistance between the junction and the bottom surface of the package.
3. θ_{jc} for CCGA packages refers to the thermal resistance between the junction and the top surface of the package.
4. The θ_{jb} values are conduction heat transfer simulation only.

Calculation for Power

Sample Case 1

A sample calculation of the power dissipation allowed for an RTAX1000S/SL-CG624 in still air is shown below. Assume that the maximum junction temperature is maintained at 110°C and the ambient temperature is 50°C. The maximum power allowed can be estimated using EQ 5.

$$T_j = 110^\circ\text{C}$$

$$T_a = 50^\circ\text{C}$$

$$\theta_{ja} = 10.8^\circ\text{C/W} = \frac{110^\circ\text{C} - 50^\circ\text{C}}{P}$$

EQ 5

$$P = 5.55 \text{ W}$$

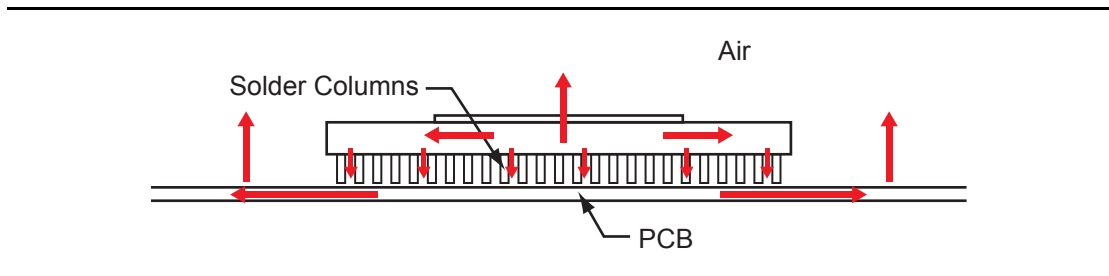

Figure 2-2 • Heat Flow when Air is Present

Sample Case 2

A sample calculation of the power dissipation when there is no air in the environment is shown below. An RTAX1000S/SL-CQ352 is attached to the board with a thermal adhesive between the package body. The thermal resistance of the paste is 0.58°C/W. Since air is not present in the environment, most of the heat will be flowing through the bottom of the package, through the thermal paste, and to the board. Neglecting the heat flowing through the package leads, the maximum power allowed can be estimated as shown in EQ 6 through EQ 9.

$$T_j = 110^\circ\text{C}$$

$$\theta_{cb} = \text{Thermal resistance of the thermal paste from case to board (i.e., = } 0.58^\circ\text{C/W)}$$

$$T_b = 70^\circ\text{C}$$

$$\theta_{jb(\text{Total})} = \frac{110^\circ\text{C} - 70^\circ\text{C}}{P}$$

EQ 6

$$\theta_{jb(\text{Total})} = \theta_{jc} + \theta_{cb}$$

EQ 7

$$\theta_{jc} + \theta_{cb} = \frac{110^\circ\text{C} - 70^\circ\text{C}}{P}$$

EQ 8

$$0.4^\circ\text{C/W} + 0.58^\circ\text{C/W} = \frac{110^\circ\text{C} - 70^\circ\text{C}}{P}$$

EQ 9

$$P = 40.8 \text{ W}$$

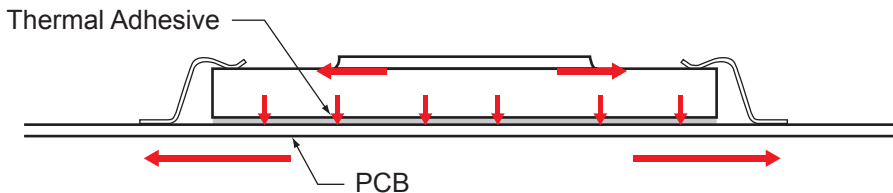
Figure 2-3 • Heat Flow in a Vacuum

The thermal resistances, shown in [Table 2-10 on page 2-9](#), are based on the simulations done with test conditions and test boards configurations specified in JEDEC specification JESD51.

Timing Characteristics

RTAX-S/SL and RTAX-DSP devices are manufactured in a CMOS process, therefore, device performance varies according to temperature, voltage, and process variations. Minimum timing parameters reflect maximum operating voltage, minimum operating temperature, and best-case processing. Maximum timing parameters reflect minimum operating voltage, maximum operating temperature, and worst-case processing. The derating factors shown in [Table 2-11](#) should be applied to all timing data contained within this datasheet.

**Table 2-11 • Temperature and Voltage Timing Derating Factors
(Normalized to Worst-Case Military, $T_J = 125^\circ\text{C}$, $V_{CCA} = 1.4\text{ V}$)**

VCCA	Junction Temperature						
	-55°C	-40°C	0°C	25°C	70°C	85°C	125°C
1.4 V	0.76	0.77	0.81	0.84	0.90	0.92	1.00
1.425 V	0.75	0.76	0.80	0.83	0.89	0.92	0.99
1.5 V	0.73	0.74	0.78	0.81	0.87	0.90	0.97
1.575 V	0.72	0.73	0.77	0.79	0.86	0.88	0.96
1.6 V	0.71	0.72	0.76	0.79	0.85	0.88	0.95

Notes:

1. The user can set the junction temperature in Designer software to be any integer value in the range of -55°C to 125°C.
2. The user can set the core voltage in Designer software to be any value between 1.4V and 1.6V.

All timing numbers listed in this datasheet represent sample timing characteristics of RTAX-S/SL and RTAX-DSP devices. Actual timing delay values are design-specific and can be derived from the SmartTime tool in Microsemi's Designer software after place-and-route.

Timing Model

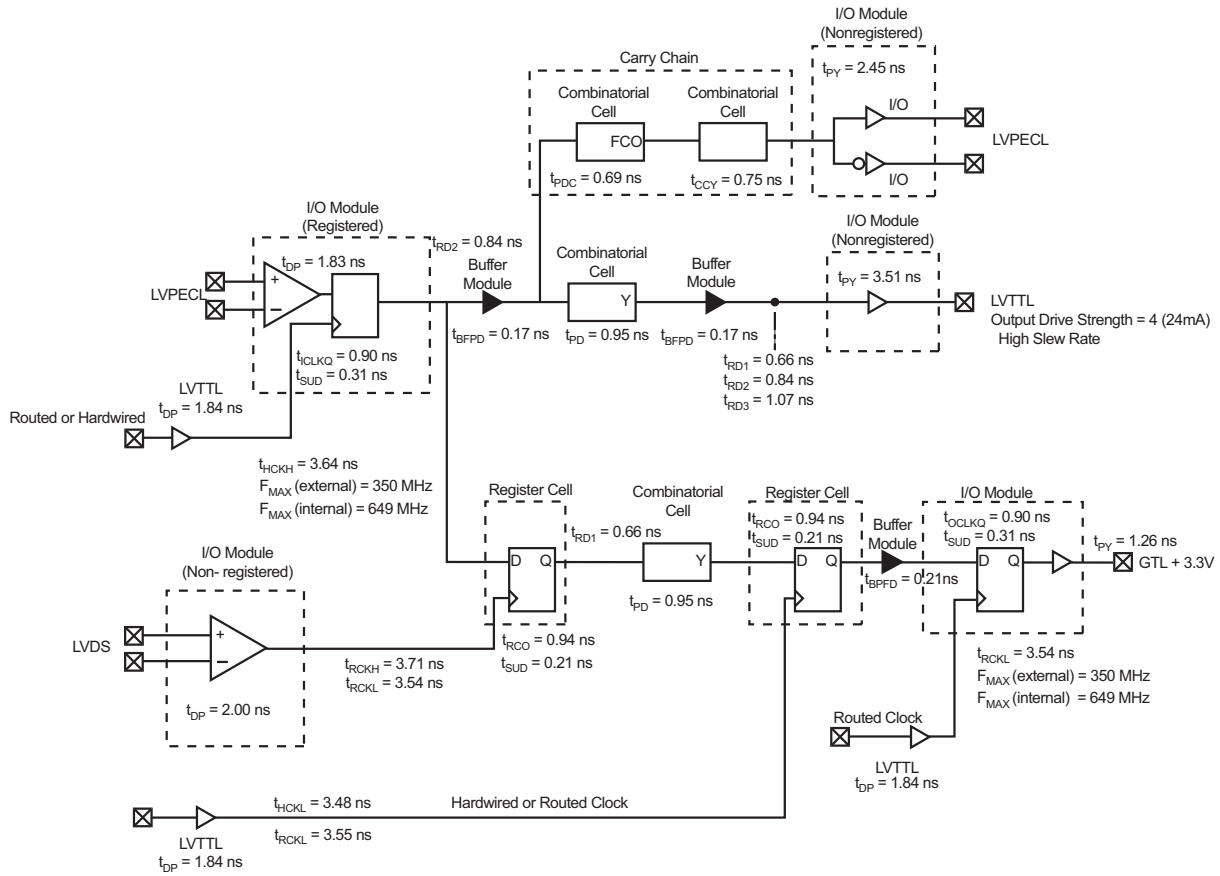

Note: Timing data is for the RTAX2000S/SL, -1 speed.

Figure 2-4 • Timing Model

Hardwired Clock¹

External Setup

$$\begin{aligned} &= (t_{DP} + t_{RD2} + t_{SUD}) - t_{HCKH} \\ &= (1.84 + 0.84 + 0.31) - 3.64 \\ &= -0.65 \end{aligned}$$

Clock-to-Out (Pad-to-Pad)

$$\begin{aligned} &= t_{HCKH} + t_{RCO} + t_{RD1} + t_{PY} \\ &= 3.64 + 0.94 + 0.66 + 3.51 \\ &= 8.75 \text{ ns} \end{aligned}$$

Routed Clock

External Setup

$$\begin{aligned} &= (t_{DP} + t_{RD2} + t_{SUD}) - t_{RCKH} \\ &= (1.84 + 0.84 + 0.31) - 3.54 \\ &= -0.72 \text{ ns} \end{aligned}$$

Clock-to-Out (Pad-to-Pad)

$$\begin{aligned} &= t_{RCKH} + t_{RCO} + t_{RD1} + t_{PY} \\ &= 3.71 + 0.94 + 0.66 + 3.51 \\ &= 8.82 \text{ ns} \end{aligned}$$

1. Calculations are examples of how to calculate related parameters and do not necessarily match the path represented in the "Timing Model".

I/O Specifications

Pin Descriptions

Supply Pins

GND **Ground**

Low supply voltage.

VCCA **Supply Voltage**

Supply voltage for array (1.5 V).

VCCIBx **Supply Voltage**

Supply voltage for I/Os. Bx is the I/O Bank ID – 0 to 7. See "User I/Os" on page 2-16 for more information. Unused VCCIBX I/O banks may be tied to GND or can be tied to other used VCCIBX I/O banks within the same device.

VCCDA **Supply Voltage**

Supply voltage for the I/O differential amplifier and JTAG and probe interfaces. VCCDA is either 3.3 V or 2.5 V and must use 3.3 V when voltage-referenced and/or differential is used. Additionally, VCCDA must be greater than or equal to any VCCI voltages (i.e. $VCCDA \geq VCCIBx$).

VPUMP **Supply Voltage (External Pump)**

External supply voltage to drive the charge pump, which controls the isolation transistors of logic modules. There is also an internal source which can power the charge pump. The external pump uses less current than the internal pump. VPUMP current is included in ICCDA. As a result, the user will see less ICCDA current with the external pump. Refer to Table 2-4 on page 2-3 for the ICCDA range.

To use the external pump, VPUMP must be 3.3 V to 3.6 V. To use the internal pump, the VCCA supply must be powered up and VPUMP can be directly tied or through a 1K resistor to GND.

There are no power sequencing requirements on VPUMP. If VPUMP is powered before VCCA, the device initializes with the external pump. If VPUMP is powered after VCCA, the device will initialize with the internal pump and switch to the external pump once VPUMP reaches 3.3 V.

User-Defined Supply Pins

VREF **Supply Voltage**

Reference voltage for I/O banks. VREF pins are configured by the user from regular I/O pins; VREF are not in fixed locations. There can be one or more VREF pins in an I/O bank. The user does not need to assign VREF pins for OUTBUF and TRIBUF. VREF pins are needed only for input and bidirectional I/Os.

Global Pins

HCLKA/B/C/D **Dedicated (Hardwired)
Clocks A, B, C, and D**

These pins are the clock input for sequential modules. Input levels are compatible with all supported I/O standards (there is a P/N pin pair for support of differential I/O standards). This input is directly wired to each R-cell and offers clock speeds independent of the number of R-cells being driven. HCLK pins may be used either as HCLK inputs or as user I/Os. If they are not being used for either purpose, Microsemi recommends that they are tied to a known state.

CLKE/F/G/H **Global Clocks E, F, G, and H**

These pins are clock inputs for clock distribution networks. Input levels are compatible with all supported I/O standards (there is a P/N pin pair for support of differential I/O standards). The clock input is buffered prior to clocking the R-cells. CLK pins may be used either as CLK inputs or as user I/Os. If they are not being used for either purpose, Microsemi recommends that they are tied to a known state.

JTAG/Probe Pins

PRA/B/C/D² **Probes A, B, C, and D**

The dedicated probe pins are used to output data from any user-defined design node within the device (controlled with Silicon Explorer II). These independent diagnostic pins can be used to allow real-time diagnostic output of any signal path within the device. The pins' probe capabilities can be permanently disabled to protect programmed design confidentiality. Refer to [Table 2-117 on page 2-134](#) for recommendations on pin status for flight boards.

TCK² **Test Clock**

Test clock input for JTAG boundary-scan testing and diagnostic probe (Silicon Explorer II).

TDI² **Test Data Input**

Serial input for JTAG boundary-scan testing and diagnostic probe. TDI is equipped with an internal pull-up resistor with approximately 10 k Ω resistance.

TDO² **Test Data Output**

Serial output for JTAG boundary-scan testing.

TMS **Test Mode Select**

The TMS pin controls the use of the IEEE 1149.1 boundary-scan pins (TCK, TDI, TDO, TRST). TMS is equipped with an internal pull-up resistor with approximately 10 k Ω resistance.

TRST **Boundary Scan Reset Pin**

The TRST pin functions as an active-low input to asynchronously initialize or reset the boundary scan circuit. The TRST pin is equipped with a programmable pull-up resistor with approximately 10 k Ω resistance. This pin must be hardwired to ground for flight.

Special Functions

NC **No Connection**

This pin is not connected to circuitry within the device, or to any other pin in the package. These pins can be driven to any voltage or can be left floating with no effect on the operation of the device.

-
2. Microsemi recommends that you use a series termination resistor on every probe connector (TDI, TCK, TDO, PRA, PRB, PRC, and PRD). The series termination is used to prevent data transmission corruption (i.e., due to reflection from the FPGA to the probe connector) during probing and reading back the checksum. With an internal setup we have seen 70-ohm termination resistor improved the signal transmission. Since the series termination depends on the setup, Microsemi recommends users to calculate the termination resistor for their own setup. Below is a guideline on how to calculate the resistor value.
- The resistor value should be chosen so that the sum of it and the probe signal's driver impedance equals the effective trace impedance.
- $$Z_0 = R_s + Z_d$$
- Z_0 = trace impedance (silicon explorer's breakout cable's resistance + PCB trace impedance), R_s = series termination, Z_d = probe signal's driver impedance.
- The termination resistor should be placed as close as possible to the driver.
- Among the probe signals, TDI, TCK, and TMS are driven by Silicon Explorer. A54SX16 is used in Silicon Explorer and hence the driver impedances needs to be calculated from [RTAX-S IBIS Models \(Mixed Voltage Operation\)](#). PRA, PRB, PRC, PRD, and TDO are driven by the FPGA and driver impedance can also be calculated from the [IBIS Model](#). Silicon explorer's breakout cable's resistance is usually close to 1 ohm.

User I/Os³

Introduction

The RTAX-S/SL and RTAX-DSP families feature a flexible I/O structure, supporting a range of mixed voltages (1.5 V, 1.8 V, 2.5 V, and 3.3 V) with its bank-selectable I/Os. [Table 2-12 on page 2-17](#) contains the I/O standards supported by the RTAX-S/SL and RTAX-DSP families.

Unused I/Os are configured as follows:

- Output buffer is disabled (with tristated value of Hi-Z)
- Input buffer is disabled (with tristated value of Hi-Z)
- No pull-up/pull-down is programmed

In Microsemi Designer Software, unused RTAX-S/SL I/Os are configured as tristate with no pull-up resistors.

Each I/O provides programmable slew rates, drive strengths, and weak pull-up and weak pull-down circuits. The slew rate setting is effective for both rising and falling edges.

All I/O standards are 3.3 V tolerant, and I/O standards, except 3.3 V PCI, are capable of hot insertion and cold sparing. 3.3 V PCI is also 5 V tolerant with the aid of an external resistor (see ["5 V Tolerance" on page 2-1](#)).

Each I/O includes three registers: an input (InReg), an output (OutReg), and an enable register (EnReg). By design, all user flip-flops in the RTAX-S/SL and RTAX-DSP FPGAs are immune to SEUs, including the following three registers located in every I/O cell buffer: InReg, OutReg, and EnReg.

I/Os are organized into banks, and there are eight banks per device – two per side ([Figure 2-7 on page 2-25](#)). Each I/O bank has a common VCCI, the supply voltage for its I/Os.

For voltage-referenced I/Os, each bank also has a common reference-voltage bus, VREF. While V_{REF} must have a common voltage for an entire I/O bank, its location is user-selectable. In other words, any user I/O in the bank can be selected to be a V_{REF} .

The location of the VREF pin should be selected according to the following rules:

- Any pin that is assigned as a VREF can control a maximum of eight user I/O pad locations in each direction (16 total maximum) within the same I/O bank.
- I/O package locations listed as no-connects are counted as part of the 16 maximum. In many cases, this leads to fewer than eight user I/O package pins in each direction being controlled by a VREF pin.
- Dedicated I/O pins (GND, VCCI...) are not counted as part of the 16.
- The user I/O pad immediately adjacent on either side of the VREF pin may only be used as an input. The exception is when there is a VCCI/GND pair separating the VREF pin and the user I/O pad location.

The differential amplifier supply voltage VCCDA should be connected to 3.3 V. When neither voltage-referenced nor differential I/Os are used, VCCDA may be connected to 2.5 V when $V_{CCI} \leq 2.5$ V in a given I/O bank; however, it is still recommended to connect VCCDA to 3.3 V.

The user can gain access to the various I/O standards in three ways:

- Instantiate specific library macros that represent the desired specific standard
- Use generic I/O macros and then use Microsemi Designer's PinEditor to specify the desired I/O standards. (Please note that this is not applicable to differential standards.)
- A combination of the first two methods

3. Do not use an external resistor to pull the I/O above V_{CCI} for a higher logic "1" voltage level. The desired higher logic "1" voltage level will be degraded due to a small I/O current, which exists when the I/O is pulled up above V_{CCI} .

Please refer to the *I/O Features in Accelerator Family Devices* application note and the *Antifuse Macro Library Guide* for more details.

Table 2-12 • I/O Standards Supported by the RTAX-S/SL and RTAX-DSP Families

I/O Standard	Input/Output Supply Voltage (VCCI)	Input Reference Voltage (VREF)	Board Termination Voltage (VTT)
LVTTTL	3.3	N/A	N/A
LVC MOS 2.5 V	2.5	N/A	N/A
LVC MOS 1.8 V	1.8	N/A	N/A
LVC MOS 1.5 V (JDEC8-11)	1.5	N/A	N/A
3.3 V PCI	3.3	N/A	N/A
GTL+ 3.3 V	3.3	1.0	1.2
GTL+ 2.5 V*	2.5	1.0	1.2
HSTL Class 1	1.5	0.75	0.75
SSTL3 Class 1 and II	3.3	1.5	1.5
SSTL2 Class1 and II	2.5	1.25	1.25
LVDS	2.5	N/A	N/A
LVPECL	3.3	N/A	N/A

Note: * 2.5 V GTL+ is not supported across the full military temperature range.

Simultaneous Switching Outputs (SSO)

Microsemi defines SSOs as any outputs that transition in phase within a 1 ns window. The measurements made by Microsemi are based on the following worst-case conditions:

1. The switching outputs are adjacent to the quiet output on either side.
2. All unused I/O buffers are tristated so they do not help either ground or V_{CC} .
3. A worst-case package was used.

When multiple output drivers switch simultaneously, they induce a voltage drop in the chip/package power distribution. This simultaneous switching momentarily raises the ground voltage within the device relative to the system ground. This apparent shift in the ground potential to a non-zero value is known as simultaneous switching noise (SSN) or more commonly, ground bounce.

SSN becomes more of an issue in high pin count packages and when using high performance devices such as the RTAX-S/SL and RTAX-DSP families.

Please refer to the *Simultaneous Switching Noise and Signal Integrity* application note for more information.

I/O Banks and Compatibility

Since each I/O bank has its own user-assigned input reference voltage (VREF) and an input/output supply voltage (V_{CCI}), only I/Os with compatible standards can be assigned to the same bank.

Table 2-13 shows the compatible I/O standards for a common VREF (for voltage-referenced standards). Similarly, Table 2-14 on page 2-18 shows compatible standards for a common VCCI.

Table 2-13 • Compatible I/O Standards for Different VREF Values

VREF	Compatible Standards
1.5 V	SSTL 3 (Class I and II)
1.25 V	SSTL 2 (Class I and II)
1.0 V	GTL+ (2.5 V and 3.3 V Outputs)
0.75 V	HSTL (Class I)

Table 2-14 • Compatible I/O Standards for Different VCCI Values

VCCI ¹	Compatible Standards	VREF
3.3 V	LVTTL, PCI, LVPECL, GTL+ 3.3V	1.0
3.3 V	SSTL 3 (Class I and II), LVTTL, PCI, LVPECL	1.5
2.5 V	LVC MOS 2.5V, GTL+ 2.5V, LVDS ²	1.0
2.5 V	LVC MOS 2.5V, SSTL 2 (Classes I and II), LVDS ²	1.25
1.8 V	LVC MOS 1.8V	N/A
1.5 V	LVC MOS 1.5V, HSTL Class I	0.75

Notes:

1. VCCI is used for both inputs and outputs.
2. Refer to [Table 2-3 on page 2-2](#) for VCCI tolerances.

[Table 2-15 on page 2-19](#) summarizes the different combinations of voltages and I/O standards that can be used together in the same I/O bank. Note that two I/O standards are compatible if:

- Their VCCI values are identical
- Their VREF standards are identical (if applicable)

For example, if LVTTL 3.3 V (VREF = 1.0 V) is used, then the other available (i.e., compatible) I/O standards in the same bank are GTL+ and LVPECL.

Also note that when multiple I/O standards are used within a bank, the voltage tolerance will be limited to the minimum tolerance of all I/O standards used in the bank. For instance, when using LVC MOS 2.5 (±5% VCCI tolerance) and LVDS (±5% VCCI tolerance) within an I/O bank, the maximum voltage tolerance of the bank will be ±5% VCCI.

Table 2-15 • Legal I/O Usage Matrix

I/O Standard	LVTTTL 3.3 V	LVC MOS 2.5 V	LVC MOS 1.8 V	LVC MOS 1.5 V (JESD8-11)	3.3 V PCI	GTL + (3.3 V)	GTL + (2.5 V)	HSTL Class I (1.5 V)	SSTL2 Class I & II (2.5 V)	SSTL3 Class I & II (3.3 V)	LVDS (2.5 V ±5%)	LVPECL (3.3 V)
LVTTTL 3.3 V (VREF = 1.0 V)	✓	-	-	-	✓	✓	-	-	-	-	-	✓
LVTTTL 3.3 V (VREF = 1.5 V)	✓	-	-	-	✓	-	-	-	-	✓	-	✓
LVC MOS 2.5 V (VREF = 1.0 V)	-	✓	-	-	-	-	✓	-	-	-	✓	-
LVC MOS 2.5 V (VREF = 1.25 V)	-	✓	-	-	-	-	-	-	✓	-	✓	-
LVC MOS 1.8 V	-	-	✓	-	-	-	-	-	-	-	-	-
LVC MOS 1.5 V (VREF = 1.75 V) (JESD8-11)	-	-	-	✓	-	-	-	✓	-	-	-	-
3.3 V PCI (VREF=1.0 V)	✓	-	-	-	✓	✓	-	-	-	-	-	✓
3.3 V PCI (VREF=1.5 V)	✓	-	-	-	✓	-	-	-	-	✓	-	✓
GTL+ (3.3 V)	✓	-	-	-	✓	✓	-	-	-	-	-	✓
GTL+ (2.5 V)	-	✓	-	-	-	-	✓	-	-	-	-	-
HSTL Class I	-	-	-	✓	-	-	-	✓	-	-	-	-
SSTL2 Class I & II	-	✓	-	-	-	-	-	-	✓	-	✓	-
SSTL3 Class I & II	✓	-	-	-	✓	-	-	-	-	✓	-	✓
LVDS (VREF=1.0 V)	-	✓	-	-	-	-	✓	-	-	-	✓	-
LVDS (VREF=1.25 V)	-	✓	-	-	-	-	-	-	✓	-	✓	-
LVPECL (VREF=1.0 V)	✓	-	-	-	✓	✓	-	-	-	-	-	✓
LVPECL (VREF=1.5 V)	✓	-	-	-	✓	-	-	-	-	✓	-	✓

Notes:

- Note that GTL+2.5 V is not supported across the full military temperature range.
- A "✓" indicates whether standards can be used within a bank at the same time.

Examples:

- LVTTTL can be used with 3.3 V PCI and GTL+ (3.3 V), when VREF = 1.0 V (GTL+ requirement).
- LVTTTL can be used with 3.3 V PCI and SSTL3 Class I and II, when VREF = 1.5 V (SSTL3 requirement).
- LVDS VCCI = 2.5 V ±5%.

I/O Clusters

Each I/O cluster incorporates two I/O modules, four RX modules and two TX modules, and a buffer module. In turn, each I/O module contains one Input Register (InReg), one Output Register (OutReg), and one Enable Register (EnReg) (Figure 2-5).

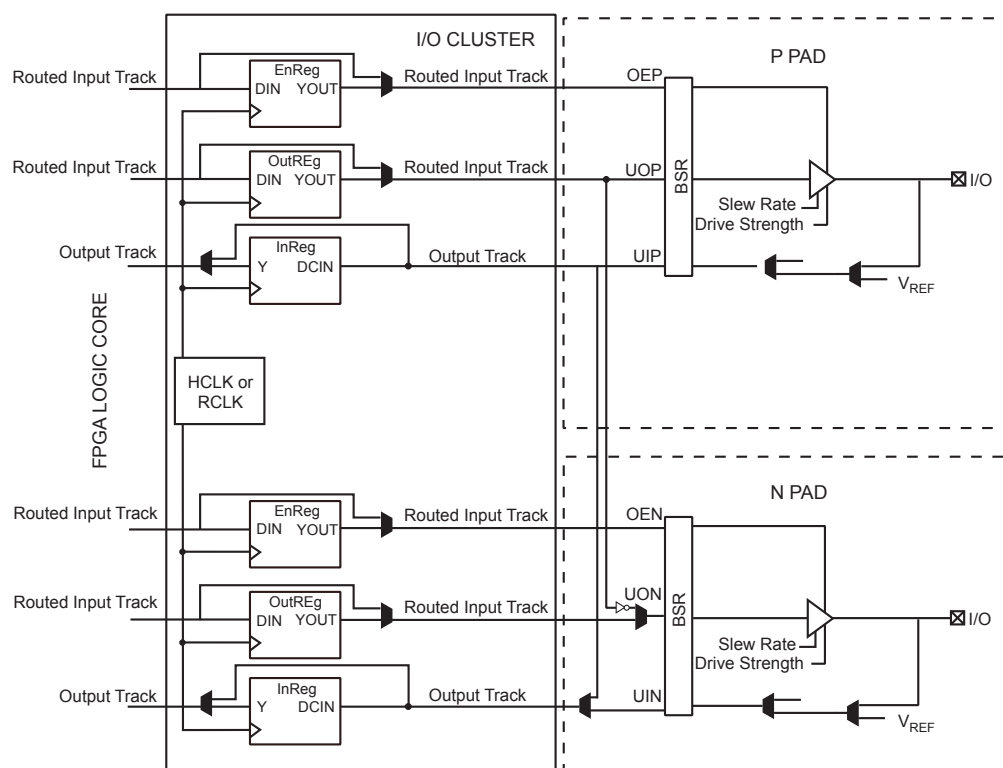

Figure 2-5 • I/O Cluster Interface

Using an I/O Register

To access the I/O registers, registers must be instantiated in the netlist and then connected to the I/Os. Usage of each I/O register (register combining) is individually controlled and can be selected/deselected using the PinEditor tool in Microsemi's Designer software. I/O register combining can also be controlled at the device level, affecting all I/Os. Please note, the I/O register option is deselected by default in any given design.⁴

In addition, Designer software provides a global option to enable/disable the usage of registers in the I/Os. This option is design specific. The setting for each individual I/O overrides this global option. Furthermore, the Global Set Fuse option in the Designer software, when checked, causes all I/O registers to output logic HIGH at device power-up.

Using the Weak Pull-Up and Pull-Down Circuits

Each RTAX-S/SL/DSP I/O comes with a weak pull-up/-down circuit (refer to Table 2-21 on page 2-26). These are weak transistors with the gates tied on, so the on resistance of the transistor emulates a resistor. The weak pull-up and pull-down is active only after the device is powered up, and they must be biased to be on. When the rails are coming up, they are not biased fully, so they do not behave as resistors until the voltage is at sufficient levels to bias the transistors. The key is they really are transistors; they are not traces of poly silicon, which is another way to do an on-chip resistor (those take much more room).

I/O macros are provided for combinations of pull-up/-down for LVTTTL, LVCMOS (2.5 V, 1.8 V, and 1.5 V) standards. These macros can be instantiated if a keeper circuit for any input buffer is required.

4. Please note that register combining for multi fanout nets is not supported.

Customizing the I/O

- A five-bit programmable input delay element is associated with each I/O. The value of this delay is set on a bank-wide basis (Table 2-16). It is optional for each input buffer within the bank (i.e. the user can enable or disable the delay element for the I/O). When the input buffer drives a register within the I/O, the delay element is activated by default to ensure a zero hold-time. The default setting for this property can be set in Designer. When the input buffer does not drive a register, the delay element is deactivated to provide higher performance. Again, this can be overridden by changing the default setting for this property in Designer.
- The slew-rate value for the LVTTTL output buffer can be programmed and can be set to either slow or fast.
- The drive strength value for LVTTTL output buffers can be programmed as well. There are four different drive strength values – 8 mA, 12 mA, 16 mA, or 24 mA – that can be specified in Designer.⁵

Table 2-16 • Bank Wide Delay Values

Bit Setting	-1	Std.
	Delay (ns)	
0	0.88	1.03
1	1.10	1.29
2	1.21	1.42
3	1.44	1.69
4	1.53	1.80
5	1.75	2.06
6	1.86	2.19
7	2.09	2.46
8	2.16	2.54
9	2.38	2.80
10	2.49	2.93
11	2.72	3.20
12	2.81	3.30
13	3.04	3.57
14	3.15	3.70
15	3.37	3.96
16	3.39	3.98
17	3.61	4.25
18	3.72	4.38
19	3.95	4.64
20	4.04	4.75
21	4.27	5.01
22	4.38	5.14
23	4.60	5.41
24	4.67	5.49
25	4.90	5.76
26	5.01	5.89
27	5.23	6.15
28	5.32	6.26
29	5.55	6.52
30	5.66	6.65
31	5.88	6.92

Note: Data shown in the table above was measured at $V_{CCA} = 1.425$ and 125°C .

5. These values are minimum drive strengths.

Using the Differential I/O Standards

Differential I/O macros should be instantiated in the netlist. The settings for these I/O standards cannot be changed inside Designer. Note that there are no tristated or bidirectional I/O buffers for differential standards.

Using the Voltage-Referenced I/O Standards

Using these I/O standards is similar to that of single-ended I/O standards. Their settings can be changed in Designer.

Using DDR (Double Data Rate)

In Double Data Rate mode, new data is present on every transition of the clock signal. Clock and data lines have identical bandwidth and signal integrity requirements, making it very efficient for implementing very high-speed systems.

To implement a DDR, users must do the following:

1. Instantiate an input buffer (with the required I/O standard).
2. Instantiate the DDR_REG macro (Figure 2-6 on page 2-22).
3. Connect the output from the Input buffer to the input of the DDR macro.
4. DDR supports all I/O standards.
5. The DDR macro in SmartGen can be used to implement DDR.
6. Bit width and I/O standard can be chosen in SmartGen.

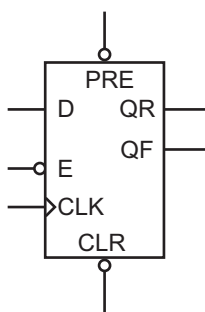

Figure 2-6 • DDR Register

Macros for Specific I/O Standards

There are different macro types for any I/O standard or feature that determine the required V_{CCI} and V_{REF} voltages for an I/O. The generic buffer macros require the LVTTTL standard with slow slew rate and 24 mA-drive strength. LVTTTL can support high slew rate but this should only be used for critical signals.

Most of the macro symbols represent variations of the six generic symbol types:

- CLKBUF: Clock Buffer
- HCLKBUF: Hardwired Clock Buffer
- INBUF: Input Buffer
- OUTBUF: Output Buffer
- TRIBUFF: Tristate Buffer
- BIBUF: Bidirectional Buffer

Other macros include the following:

- Differential I/O standard macros: The LVDS and LVPECL macros either have a pair of differential inputs (e.g. INBUF_LVDS) or a pair of differential outputs (e.g. OUTBUF_LVPECL).
- Pull-up and pull-down variations of the INBUF, BIBUF, and TRIBUFF macros. These are available only with TTL and LVCMOS thresholds. They can be used to model the behavior of the pull-up and pull-down resistors available in the architecture. Whenever an input pin is left unconnected, the output pin will either go high or low rather than unknown. This allows users to leave inputs unconnected without having the negative effect on simulation of propagating unknowns.

- DDR_REG macro. It can be connected to any I/O standard input buffers (i.e., INBUF) to implement a double data rate register. Designer software will map it to the I/O module in the same way it maps the other registers to the I/O module.

Table 2-17, Table 2-18 on page 2-24, and Table 2-19 on page 2-24 list all the available macro names differentiated by I/O standard, type, slew rate, and drive strength.

Table 2-17 • Macros for Single-Ended I/O Standards

Standard	VCCI	Macro Names
LVTTTL	3.3 V	CLKBUF, HCLKBUF INBUF, OUTBUF, OUTBUF_S_8, OUTBUF_S_12, OUTBUF_S_16, OUTBUF_S_24, OUTBUF_F_8, OUTBUF_F_12, OUTBUF_F_16, OUTBUF_F_24, TRIBUFF, TRIBUFF_S_8, TRIBUFF_S_12, TRIBUFF_S_16, TRIBUFF_S_24, TRIBUFF_F_8, TRIBUFF_F_12, TRIBUFF_F_16, TRIBUFF_F_24, BIBUF, BIBUF_S_8, BIBUF_S_12, BIBUF_S_16, BIBUF_S_24, BIBUF_F_8, BIBUF_F_12, BIBUF_F_16, BIBUF_F_24,
3.3V PCI	3.3 V	CLKBUF_PCI, HCLKBUF_PCI, INBUF_PCI, OUTBUF_PCI, TRIBUFF_PCI, BIBUF_PCI
LVC MOS25	2.5 V	CLKBUF_LVC MOS25, HCLKBUF_LVC MOS25, INBUF_LVC MOS25, OUTBUF_LVC MOS25, TRIBUFF_LVC MOS25, BIBUF_LVC MOS25
LVC MOS18	1.8 V	CLKBUF_LVC MOS18, HCLKBUF_LVC MOS18, INBUF_LVC MOS18, OUTBUF_LVC MOS18, TRIBUFF_LVC MOS18, BIBUF_LVC MOS18
LVC MOS15 (JESD8-11)	1.5 V	CLKBUF_LVC MOS15, HCLKBUF_LVC MOS15, INBUF_LVC MOS15, OUTBUF_LVC MOS15, TRIBUFF_LVC MOS15, BIBUF_LVC MOS15

Table 2-18 • I/O Macros for Differential I/O Standards

Standard	VCCI	Macro Names
LVPECL	3.3 V	CLKBUF_LVPECL, HCLKBUF_LVPECL, INBUF_LVPECL, OUTBUF_LVPECL
LVDS	2.5 V	CLKBUF_LVDS, HCLKBUF_LVDS, INBUF_LVDS, OUTBUF_LVDS

Table 2-19 • I/O Macros for Voltage-Referenced I/O Standards

Standard	VCCI	VREF	Macro Names
GTL+	3.3 V	1.0 V	CLKBUF_GTP33, HCLKBUF_GTP33, INBUF_GTP33, OUTBUF_GTP33, TRIBUFF_GTP33, BIBUF_GTP33
GTL+	2.5 V	1.0 V	CLKBUF_GTP25, HCLKBUF_GTP25, INBUF_GTP25, OUTBUF_GTP25, TRIBUFF_GTP25, BIBUF_GTP25
SSTL2 Class I	2.5 V	1.25 V	CLKBUF_SSTL2_I, HCLKBUF_SSTL2_I, TRIBUFF_SSTL2_I, BIBUF_SSTL2_I, INBUF_SSTL2_I, OUTBUF_SSTL2_I
SSTL2 Class II	2.5 V	1.25 V	CLKBUF_SSTL2_II, HCLKBUF_SSTL2_II, TRIBUFF_SSTL2_II, BIBUF_SSTL2_II, INBUF_SSTL2_II, OUTBUF_SSTL2_II
SSTL3 Class I	3.3 V	1.5 V	CLKBUF_SSTL3_I, HCLKBUF_SSTL3_I, TRIBUFF_SSTL3_I, BIBUF_SSTL3_I, INBUF_SSTL3_I, OUTBUF_SSTL3_I
SSTL3 Class II	3.3 V	1.5 V	CLKBUF_SSTL3_II, HCLKBUF_SSTL3_II, TRIBUFF_SSTL3_II, BIBUF_SSTL3_II, INBUF_SSTL3_II, OUTBUF_SSTL3_II
HSTL Class I	1.5 V	0.75 V	CLKBUF_HSTL_I, BIBUF_HSTL_I, HCLKBUF_HSTL_I, INBUF_HSTL_I, OUTBUF_HSTL_I, TRIBUFF_HSTL_I

User I/O Naming Conventions

Due to the complex and flexible nature of the RTAX-S/SL family's user I/Os, a naming scheme is used to show the details of the I/O. The naming scheme explains to which bank an I/O belongs, as well as the pairing and pin polarity for differential I/Os (Figure 2-7).

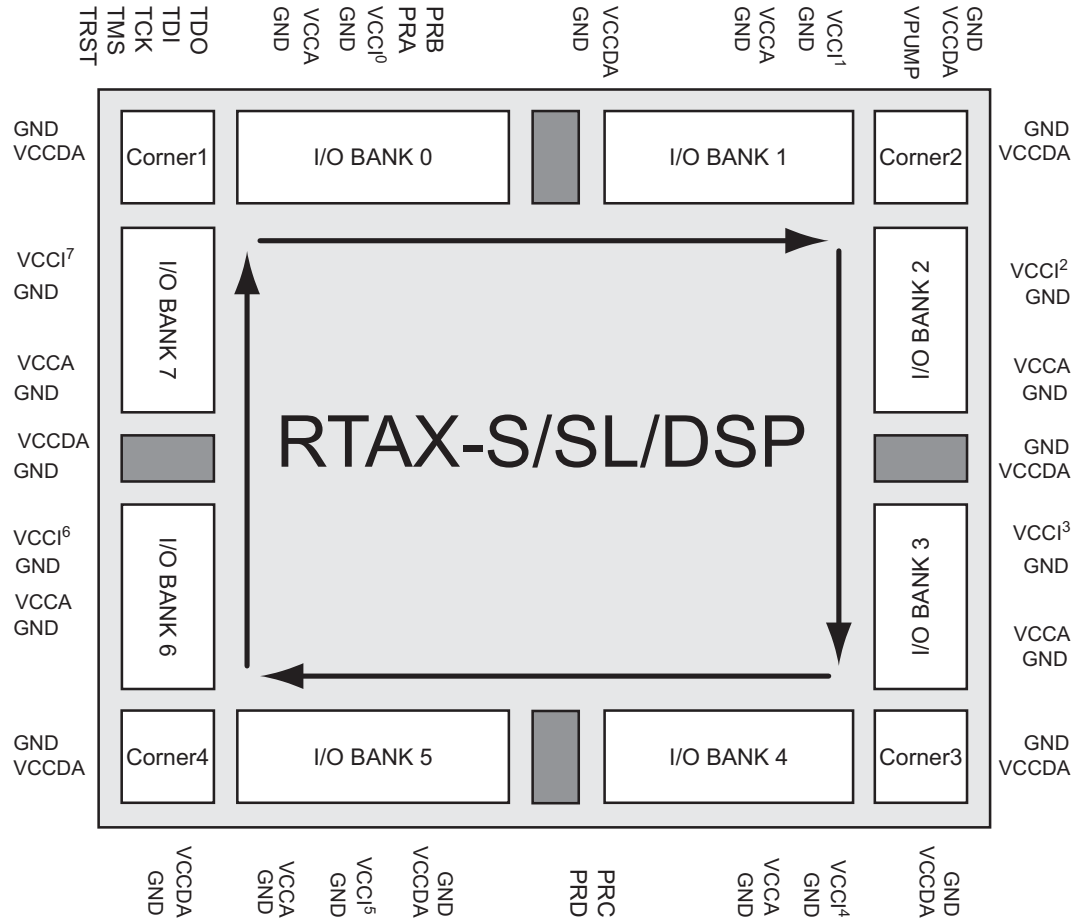
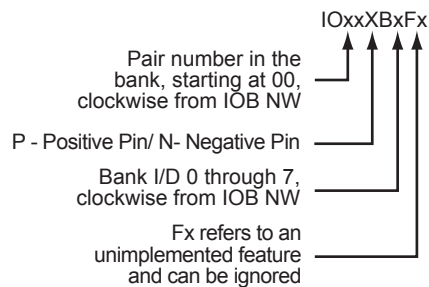

Figure 2-7 • I/O Bank and Dedicated Pin Layout



Examples:

IO12PB1F1 Is the positive pin of the thirteenth pair of the first I/O bank (IOB NE). IO12PB1 combined with IO12NB1 form a differential pair.

For those I/Os that can be employed either as a user I/O or as a special function, the following nomenclature is used:

IOxxXBxFx/special_function_name

IOxxPB1Fx/CLKx This pin can be configured as a clock input or as a user I/O

Figure 2-8 • General Naming Schemes

I/O Standard Electrical Specifications

Table 2-20 • Input Capacitance

Symbol	Parameter	Conditions	Min.	Max.	Units
C _{IN}	Input capacitance	V _{IN} = 0, f = 1.0 MHz		10	pF
C _{INCLK}	Input capacitance on HCLK and RCLK pin	V _{IN} = 0, f = 1.0 MHz		10	pF

Table 2-21 • I/O Weak Pull-Up/Pull-Down Resistances¹

I/O Configuration (VCCI)	R _{WEAK PULL-UP} (kΩ) ¹		R _{WEAK PULL-DOWN} (kΩ) ²	
	Min.	Max.	Min.	Max.
3.3 V	35	65	30	60
2.5 V	50	75	40	85
1.8 V	80	140	70	130
1.5 V	100	210	90	180

Notes:

- $R_{(WEAK\ PULL-UP-MAX)} = (VCCImax - VOHspec) / I_{WEAK\ PULL-UP-MIN}$
- $R_{(WEAK\ PULL-DOWN-MAX)} = (VOLspec) / I_{WEAK\ PULL-DOWN-MIN}$

Table 2-22 • I/O Input Rise Time and Fall Time*

Input Buffer	Input Rise/Fall Time (Min)	Input Rise/Fall Time (Max)
LVTTTL	No Requirement	50 ns
LVC MOS 2.5 V	No Requirement	50 ns
LVC MOS 1.8 V	No Requirement	50 ns
LVC MOS 1.5 V	No Requirement	50 ns
PCI	No Requirement	50 ns
PCIX	No Requirement	50 ns
GTL+	No Requirement	50 ns
HSTL	No Requirement	50 ns
SSTL2	No Requirement	50 ns
HSTL3	No Requirement	50 ns
LVDS	No Requirement	50 ns
LVPECL	No Requirement	50 ns

Note: *Input Rise/Fall time applies to all inputs, including clock or data. Inputs have to ramp up/down linearly, in a monotonic way. Glitches or a plateau may cause double-clocking. They must be avoided. For Output Rise/Fall time, refer to *IBIS Models* for extraction.

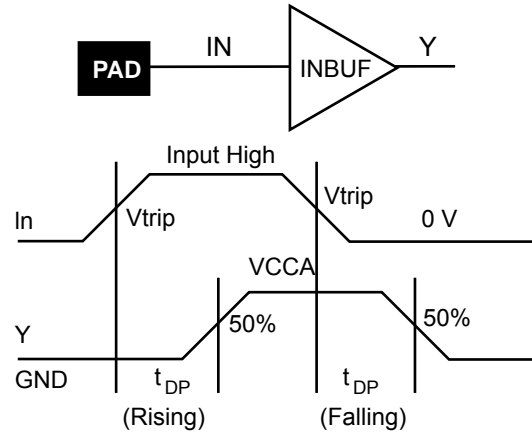
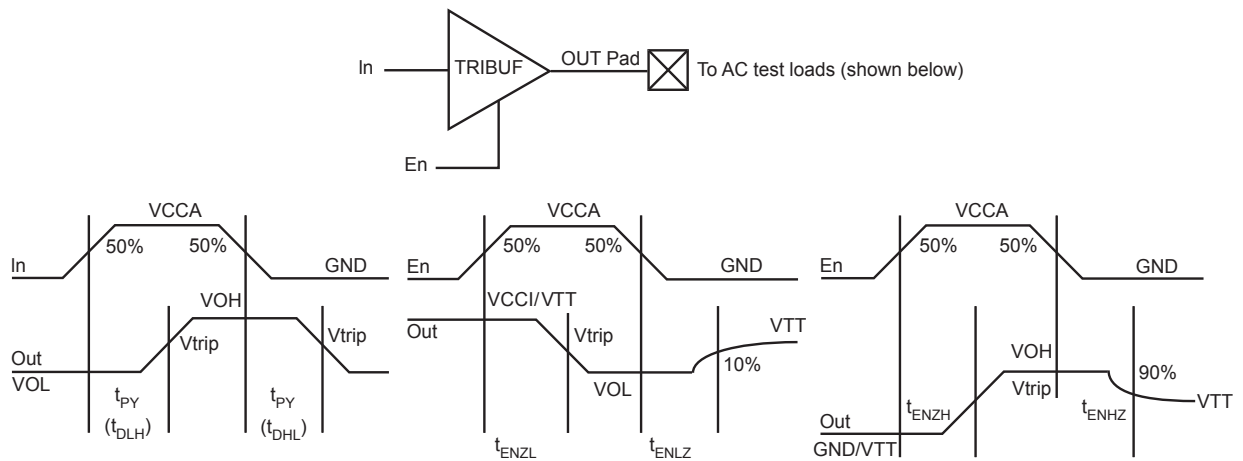
Figure 2-9 • Input Buffer Delays

Figure 2-10 • Output Buffer Delays

I/O Module Timing Characteristics

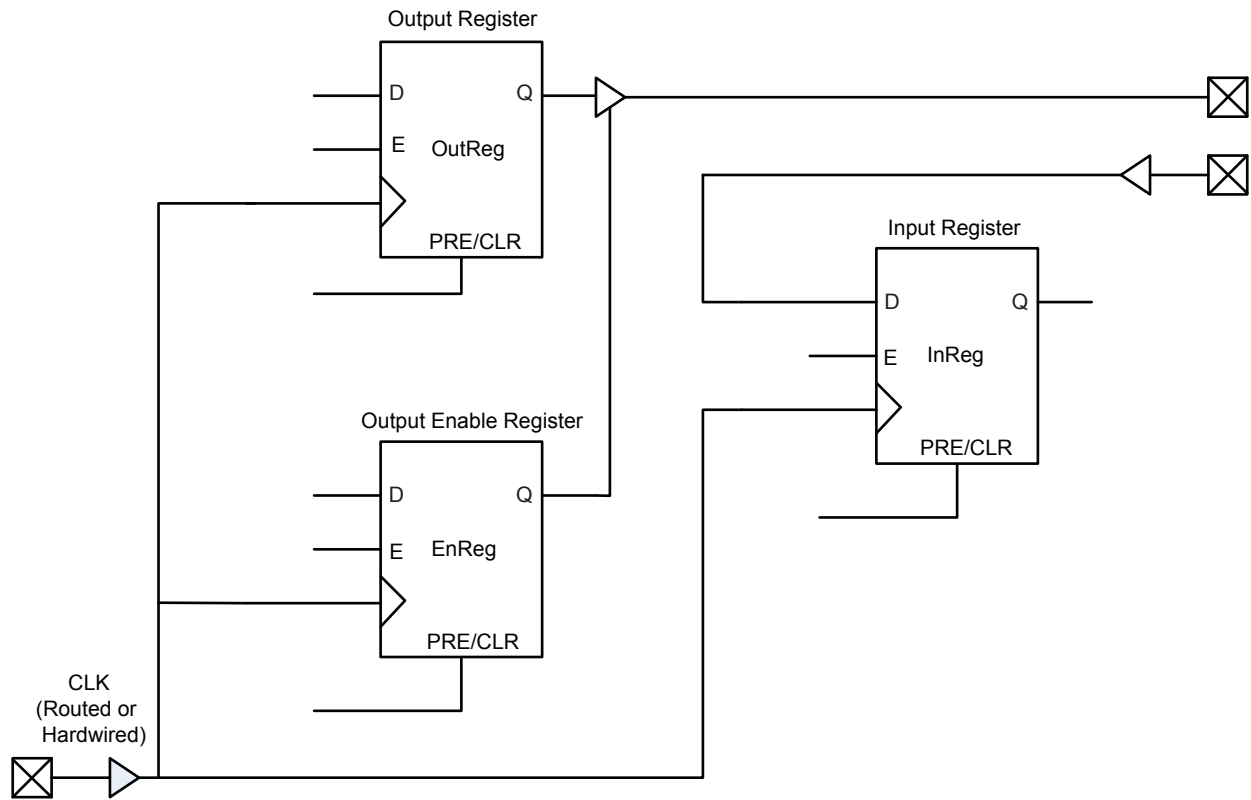

Figure 2-11 • Timing Model

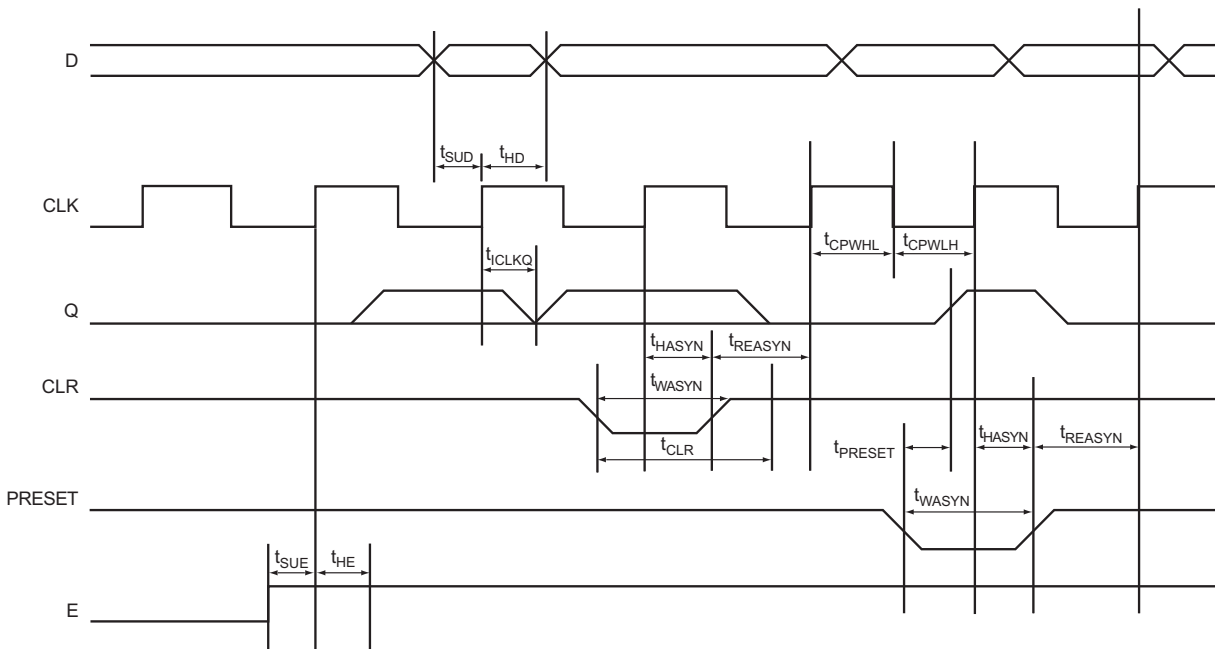
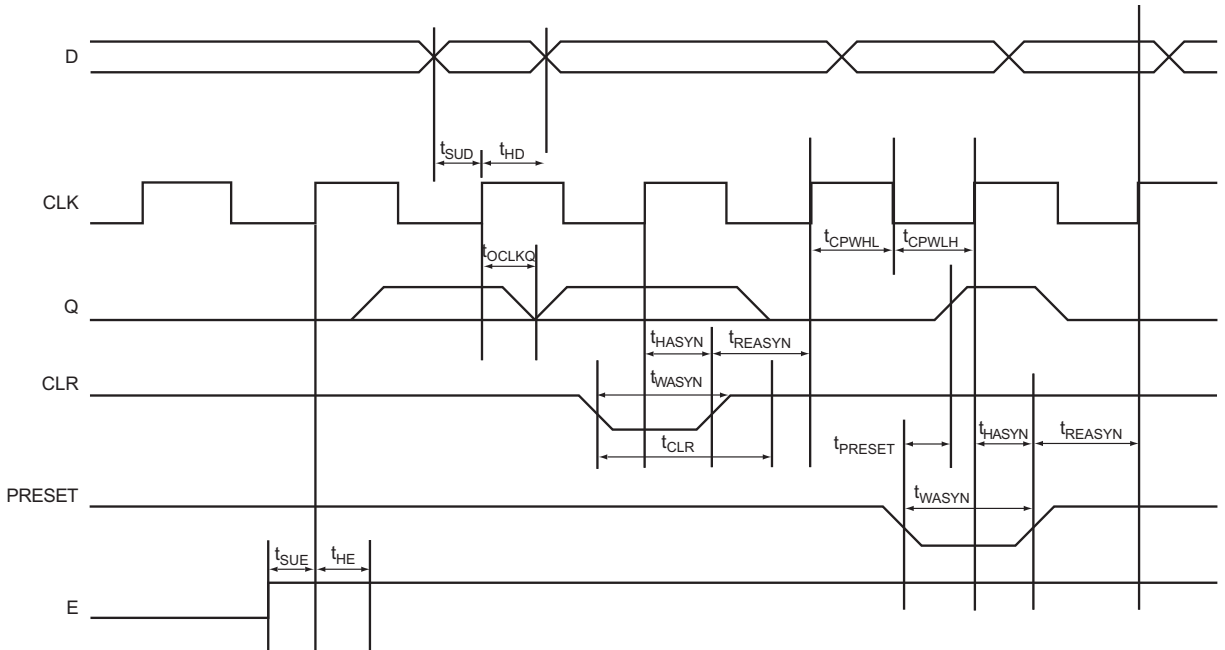
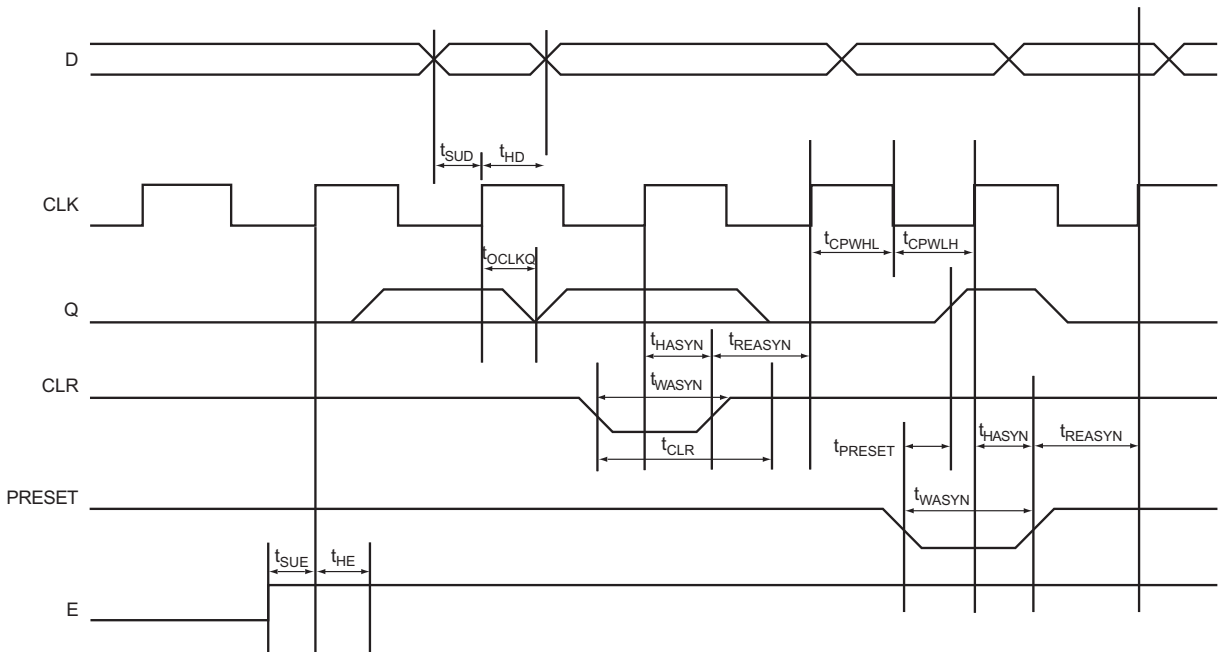

Figure 2-12 • Input Register Timing Characteristics

Figure 2-13 • Output Register Timing Characteristics

Figure 2-14 • Output Enable Register Timing Characteristics

3.3 V LVTTTL

Low-Voltage Transistor-Transistor Logic is a general purpose standard (EIA/JESD) for 3.3 V applications. It uses an LVTTTL input buffer and push-pull output buffer.

Table 2-23 • DC Input and Output Levels

VIL		VIH		VOL	VOH	IOL	IOH
Min. V	Max. V	Min. V	Max. V	Max. V	Min. V	mA	mA
-0.3	0.8	2.0	3.6	0.4*	2.4	24	-24

Note: For RTAX250S/SL-CQ352 devices only, VOL limits are 500 mV across all operating temperatures.

AC Loadings

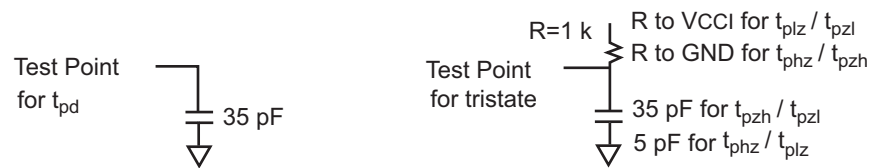

Figure 2-15 • AC Test Loads

Table 2-24 • AC Waveforms, Measuring Points, and Capacitive Load

Input Low (V)	Input High (V)	Measuring Point* (V)	VREF (typ) (V)	C _{load} (pF)
0	3.0	1.40	N/A	35

Note: * Measuring Point = V_{trip}

Timing Characteristics

Table 2-25 • Worst-Case Military Conditions VCCA = 1.425 V, VCCI = 3.0 V, T_J = 125°C

Parameter	Description	-1 Speed				Std. Speed		Units
		RTAX4000S/SL		RTAX250/1000/2000S/SL		All		
		Min.	Max.	Min.	Max.	Min.	Max.	
LVTTTL I/O Module Drive Strength = 1 (8 mA) / Low Slew Rate								
t _{DP}	Input buffer		1.96		1.84		2.17	ns
t _{PY}	Output buffer		16.78		15.82		18.60	ns
t _{ENZL}	Enable to Pad delay through the Output Buffer—Z to Low		17.65		16.64		19.56	ns
t _{ENZH}	Enable to Pad delay through the Output Buffer—Z to High		16.51		15.56		18.29	ns
t _{ENLZ}	Enable to Pad delay through the Output Buffer—Low to Z		2.55		2.41		2.83	ns
t _{ENHZ}	Enable to Pad delay through the Output Buffer—High to Z		3.26		3.07		3.61	ns
t _{IOCLKQ}	Sequential clock-to-Q for the input register		0.95		0.90		1.05	ns
t _{IOCLKY}	Clock-to-output Y for the I/O output register and the enable register		0.95		0.90		1.05	ns
t _{SUD}	Data input setup		0.33		0.31		0.36	ns
t _{SUE}	Enable input setup		0.36		0.34		0.40	ns
t _{HD}	Data input hold		0.00		0.00		0.00	ns
t _{HE}	Enable input hold		0.00		0.00		0.00	ns
t _{CPWHL}	Clock pulse width High to Low	0.39		0.39		0.39		ns
t _{CPWLH}	Clock pulse width Low to High	0.39		0.39		0.39		ns
t _{WASYN}	Asynchronous pulse width	0.37		0.37		0.37		ns
t _{REASYN}	Asynchronous recovery time		0.18		0.17		0.20	ns
t _{HASYN}	Asynchronous removal time		0.00		0.00		0.00	ns
t _{CLR}	Asynchronous Clear-to-Q		0.33		0.31		0.37	ns
t _{PRESET}	Asynchronous Preset-to-Q		0.33		0.31		0.37	ns

Table 2-25 • Worst-Case Military Conditions VCCA = 1.425 V, VCCI = 3.0 V, T_J = 125°C (continued)

Parameter	Description	-1 Speed				Std. Speed		Units
		RTAX4000S/SL		RTAX250/1000/2000S/SL		All		
		Min.	Max.	Min.	Max.	Min.	Max.	
LVTTTL I/O Module Drive Strength = 2 (12 mA) / Low Slew Rate								
t _{DP}	Input buffer		1.96		1.84		2.17	ns
t _{py}	Output buffer		14.06		13.25		15.58	ns
t _{ENZL}	Enable to Pad delay through the Output Buffer—Z to Low		14.39		13.56		15.94	ns
t _{ENZH}	Enable to Pad delay through the Output Buffer—Z to High		14.09		13.28		15.61	ns
t _{ENLZ}	Enable to Pad delay through the Output Buffer—Low to Z		2.84		2.68		3.15	ns
t _{ENHZ}	Enable to Pad delay through the Output Buffer—High to Z		3.71		3.50		4.11	ns
t _{iOCLKQ}	Sequential clock-to-Q for the input register		0.95		0.90		1.05	ns
t _{iOCLKY}	Clock-to-output Y for the I/O output register and the enable register		0.95		0.90		1.05	ns
t _{SUD}	Data input setup		0.33		0.31		0.36	ns
t _{SUE}	Enable input setup		0.36		0.34		0.40	ns
t _{HD}	Data input hold		0.00		0.00		0.00	ns
t _{HE}	Enable input hold		0.00		0.00		0.00	ns
t _{CPWHL}	Clock pulse width High to Low	0.39		0.39		0.39		ns
t _{CPWLH}	Clock pulse width Low to High	0.39		0.39		0.39		ns
t _{WASYN}	Asynchronous pulse width	0.37		0.37		0.37		ns
t _{REASYN}	Asynchronous recovery time		0.18		0.17		0.20	ns
t _{HASYN}	Asynchronous removal time		0.00		0.00		0.00	ns
t _{CLR}	Asynchronous Clear-to-Q		0.33		0.31		0.37	ns
t _{PRESET}	Asynchronous Preset-to-Q		0.33		0.31		0.37	ns

Table 2-25 • Worst-Case Military Conditions VCCA = 1.425 V, VCCI = 3.0 V, T_J = 125°C (continued)

Parameter	Description	-1 Speed				Std. Speed		Units
		RTAX4000S/SL		RTAX250/1000/2000S/SL		All		
		Min.	Max.	Min.	Max.	Min.	Max.	
LVTTTL I/O Module Drive Strength = 3 (16 mA) / Low Slew Rate								
t _{DP}	Input buffer		1.96		1.84		2.17	ns
t _{py}	Output buffer		12.78		12.04		14.16	ns
t _{ENZL}	Enable to Pad delay through the Output Buffer—Z to Low		13.22		12.46		14.65	ns
t _{ENZH}	Enable to Pad delay through the Output Buffer—Z to High		12.79		12.05		14.17	ns
t _{ENLZ}	Enable to Pad delay through the Output Buffer—Low to Z		3.06		2.88		3.39	ns
t _{ENHZ}	Enable to Pad delay through the Output Buffer—High to Z		4.19		3.95		4.64	ns
t _{iOCLKQ}	Sequential clock-to-Q for the input register		0.95		0.90		1.05	ns
t _{iOCLKY}	Clock-to-output Y for the I/O output register and the enable register		0.95		0.90		1.05	ns
t _{SUD}	Data input setup		0.33		0.31		0.36	ns
t _{SUE}	Enable input setup		0.36		0.34		0.40	ns
t _{HD}	Data input hold		0.00		0.00		0.00	ns
t _{HE}	Enable input hold		0.00		0.00		0.00	ns
t _{CPWHL}	Clock pulse width High to Low	0.39		0.39		0.39		ns
t _{CPWLH}	Clock pulse width Low to High	0.39		0.39		0.39		ns
t _{WASYN}	Asynchronous pulse width	0.37		0.37		0.37		ns
t _{REASYN}	Asynchronous recovery time		0.18		0.17		0.20	ns
t _{HASYN}	Asynchronous removal time		0.00		0.00		0.00	ns
t _{CLR}	Asynchronous Clear-to-Q		0.33		0.31		0.37	ns
t _{PRESET}	Asynchronous Preset-to-Q		0.33		0.31		0.37	ns

Table 2-25 • Worst-Case Military Conditions VCCA = 1.425 V, VCCI = 3.0 V, T_J = 125°C (continued)

Parameter	Description	-1 Speed				Std. Speed		Units
		RTAX4000S/SL		RTAX250/1000/2000S/SL		All		
		Min.	Max.	Min.	Max.	Min.	Max.	
LVTTTL I/O Module Drive Strength = 4 (24 mA) / Low Slew Rate								
t _{DP}	Input buffer		1.96		1.84		2.17	ns
t _{py}	Output buffer		12.10		11.41		13.41	ns
t _{ENZL}	Enable to Pad delay through the Output Buffer—Z to Low		12.28		11.58		13.61	ns
t _{ENZH}	Enable to Pad delay through the Output Buffer—Z to High		12.12		11.43		13.43	ns
t _{ENLZ}	Enable to Pad delay through the Output Buffer—Low to Z		3.16		2.98		3.50	ns
t _{ENHZ}	Enable to Pad delay through the Output Buffer—High to Z		4.30		4.06		4.77	ns
t _{iOCLKQ}	Sequential clock-to-Q for the input register		0.95		0.90		1.05	ns
t _{iOCLKY}	Clock-to-output Y for the I/O output register and the enable register		0.95		0.90		1.05	ns
t _{SUD}	Data input setup		0.33		0.31		0.36	ns
t _{SUE}	Enable input setup		0.36		0.34		0.40	ns
t _{HD}	Data input hold		0.00		0.00		0.00	ns
t _{HE}	Enable input hold		0.00		0.00		0.00	ns
t _{CPWHL}	Clock pulse width High to Low	0.39		0.39		0.39		ns
t _{CPWLH}	Clock pulse width Low to High	0.39		0.39		0.39		ns
t _{WASYN}	Asynchronous pulse width	0.37		0.37		0.37		ns
t _{REASYN}	Asynchronous recovery time		0.18		0.17		0.20	ns
t _{HASYN}	Asynchronous removal time		0.00		0.00		0.00	ns
t _{CLR}	Asynchronous Clear-to-Q		0.33		0.31		0.37	ns
t _{PRESET}	Asynchronous Preset-to-Q		0.33		0.31		0.37	ns

Table 2-25 • Worst-Case Military Conditions VCCA = 1.425 V, VCCI = 3.0 V, T_J = 125°C (continued)

Parameter	Description	-1 Speed				Std. Speed		Units
		RTAX4000S/SL		RTAX250/1000/2000S/SL		All		
		Min.	Max.	Min.	Max.	Min.	Max.	
LVTTTL I/O Module Drive Strength = 1 (8 mA) / High Slew Rate								
t _{DP}	Input buffer		1.96		1.84		2.17	ns
t _{py}	Output buffer		5.07		4.78		5.62	ns
t _{ENZL}	Enable to Pad delay through the Output Buffer—Z to Low		5.37		5.06		5.95	ns
t _{ENZH}	Enable to Pad delay through the Output Buffer—Z to High		4.89		4.61		5.42	ns
t _{ENLZ}	Enable to Pad delay through the Output Buffer—Low to Z		3.11		2.93		3.44	ns
t _{ENHZ}	Enable to Pad delay through the Output Buffer—High to Z		3.36		3.17		3.72	ns
t _{iOCLKQ}	Sequential clock-to-Q for the input register		0.95		0.90		1.05	ns
t _{iOCLKY}	Clock-to-output Y for the I/O output register and the enable register		0.95		0.90		1.05	ns
t _{SUD}	Data input setup		0.33		0.31		0.36	ns
t _{SUE}	Enable input setup		0.36		0.34		0.40	ns
t _{HD}	Data input hold		0.00		0.00		0.00	ns
t _{HE}	Enable input hold		0.00		0.00		0.00	ns
t _{CPWHL}	Clock pulse width High to Low	0.39		0.39		0.39		ns
t _{CPWLH}	Clock pulse width Low to High	0.39		0.39		0.39		ns
t _{WASYN}	Asynchronous pulse width	0.37		0.37		0.37		ns
t _{REASYN}	Asynchronous recovery time		0.18		0.17		0.20	ns
t _{HASYN}	Asynchronous removal time		0.00		0.00		0.00	ns
t _{CLR}	Asynchronous Clear-to-Q		0.33		0.31		0.37	ns
t _{PRESET}	Asynchronous Preset-to-Q		0.33		0.31		0.37	ns

Table 2-25 • Worst-Case Military Conditions VCCA = 1.425 V, VCCI = 3.0 V, T_J = 125°C (continued)

Parameter	Description	-1 Speed				Std. Speed		Units
		RTAX4000S/SL		RTAX250/1000/2000S/SL		All		
		Min.	Max.	Min.	Max.	Min.	Max.	
LVTTTL I/O Module Drive Strength = 2 (12 mA) / High Slew Rate								
t _{DP}	Input buffer		1.96		1.84		2.17	ns
t _{py}	Output buffer		4.10		3.87		4.54	ns
t _{ENZL}	Enable to Pad delay through the Output Buffer—Z to Low		4.33		4.08		4.79	ns
t _{ENZH}	Enable to Pad delay through the Output Buffer—Z to High		3.55		3.34		3.93	ns
t _{ENLZ}	Enable to Pad delay through the Output Buffer—Low to Z		3.11		2.93		3.44	ns
t _{ENHZ}	Enable to Pad delay through the Output Buffer—High to Z		3.83		3.61		4.25	ns
t _{iOCLKQ}	Sequential clock-to-Q for the input register		0.95		0.90		1.05	ns
t _{iOCLKY}	Clock-to-output Y for the I/O output register and the enable register		0.95		0.90		1.05	ns
t _{SUD}	Data input setup		0.33		0.31		0.36	ns
t _{SUE}	Enable input setup		0.36		0.34		0.40	ns
t _{HD}	Data input hold		0.00		0.00		0.00	ns
t _{HE}	Enable input hold		0.00		0.00		0.00	ns
t _{CPWHL}	Clock pulse width High to Low	0.39		0.39		0.39		ns
t _{CPWLH}	Clock pulse width Low to High	0.39		0.39		0.39		ns
t _{WASYN}	Asynchronous pulse width	0.37		0.37		0.37		ns
t _{REASYN}	Asynchronous recovery time		0.18		0.17		0.20	ns
t _{HASYN}	Asynchronous removal time		0.00		0.00		0.00	ns
t _{CLR}	Asynchronous Clear-to-Q		0.33		0.31		0.37	ns
t _{PRESET}	Asynchronous Preset-to-Q		0.33		0.31		0.37	ns

Table 2-25 • Worst-Case Military Conditions VCCA = 1.425 V, VCCI = 3.0 V, T_J = 125°C (continued)

Parameter	Description	-1 Speed				Std. Speed		Units
		RTAX4000S/SL		RTAX250/1000/2000S/SL		All		
		Min.	Max.	Min.	Max.	Min.	Max.	
LVTTTL I/O Module Drive Strength = 3 (16 mA) / High Slew Rate								
t _{DP}	Input buffer		1.96		1.84		2.17	ns
t _{py}	Output buffer		3.89		3.66		4.31	ns
t _{ENZL}	Enable to Pad delay through the Output Buffer—Z to Low		4.10		3.87		4.55	ns
t _{ENZH}	Enable to Pad delay through the Output Buffer—Z to High		3.22		3.03		3.56	ns
t _{ENLZ}	Enable to Pad delay through the Output Buffer—Low to Z		3.14		2.96		3.48	ns
t _{ENHZ}	Enable to Pad delay through the Output Buffer—High to Z		4.32		4.07		4.79	ns
t _{iOCLKQ}	Sequential clock-to-Q for the input register		0.95		0.90		1.05	ns
t _{iOCLKY}	Clock-to-output Y for the I/O output register and the enable register		0.95		0.90		1.05	ns
t _{SUD}	Data input setup		0.33		0.31		0.36	ns
t _{SUE}	Enable input setup		0.36		0.34		0.40	ns
t _{HD}	Data input hold		0.00		0.00		0.00	ns
t _{HE}	Enable input hold		0.00		0.00		0.00	ns
t _{CPWHL}	Clock pulse width High to Low	0.39		0.39		0.39		ns
t _{CPWLH}	Clock pulse width Low to High	0.39		0.39		0.39		ns
t _{WASYN}	Asynchronous pulse width	0.37		0.37		0.37		ns
t _{REASYN}	Asynchronous recovery time		0.18		0.17		0.20	ns
t _{HASYN}	Asynchronous removal time		0.00		0.00		0.00	ns
t _{CLR}	Asynchronous Clear-to-Q		0.33		0.31		0.37	ns
t _{PRESET}	Asynchronous Preset-to-Q		0.33		0.31		0.37	ns

Table 2-25 • Worst-Case Military Conditions VCCA = 1.425 V, VCCI = 3.0 V, T_J = 125°C (continued)

Parameter	Description	-1 Speed				Std. Speed		Units
		RTAX4000S/SL		RTAX250/1000/2000S/SL		All		
		Min.	Max.	Min.	Max.	Min.	Max.	
LVTTTL I/O Module Drive Strength = 4 (24 mA) / High Slew Rate								
t _{DP}	Input buffer		1.96		1.84		2.17	ns
t _{py}	Output buffer		3.72		3.51		4.12	ns
t _{ENZL}	Enable to Pad delay through the Output Buffer—Z to Low		3.89		3.67		4.31	ns
t _{ENZH}	Enable to Pad delay through the Output Buffer—Z to High		2.99		2.82		3.32	ns
t _{ENLZ}	Enable to Pad delay through the Output Buffer—Low to Z		3.14		2.96		3.48	ns
t _{ENHZ}	Enable to Pad delay through the Output Buffer—High to Z		4.42		4.17		4.90	ns
t _{iOCLKQ}	Sequential clock-to-Q for the input register		0.95		0.90		1.05	ns
t _{iOCLKY}	Clock-to-output Y for the I/O output register and the enable register		0.95		0.90		1.05	ns
t _{SUD}	Data input setup		0.33		0.31		0.36	ns
t _{SUE}	Enable input setup		0.36		0.34		0.40	ns
t _{HD}	Data input hold		0.00		0.00		0.00	ns
t _{HE}	Enable input hold		0.00		0.00		0.00	ns
t _{CPWHL}	Clock pulse width High to Low	0.39		0.39		0.39		ns
t _{CPWLH}	Clock pulse width Low to High	0.39		0.39		0.39		ns
t _{WASYN}	Asynchronous pulse width	0.37		0.37		0.37		ns
t _{REASYN}	Asynchronous recovery time		0.18		0.17		0.20	ns
t _{HASYN}	Asynchronous removal time		0.00		0.00		0.00	ns
t _{CLR}	Asynchronous Clear-to-Q		0.33		0.31		0.37	ns
t _{PRESET}	Asynchronous Preset-to-Q		0.33		0.31		0.37	ns

2.5 V LVCMOS

Low-Voltage Complementary Metal-Oxide Semiconductor for 2.5 V is an extension of the LVCMOS standard (JESD8-5) used for general-purpose 2.5 V applications. It uses a 3.3 V tolerant CMOS input buffer and a push-pull output buffer.

Table 2-26 • DC Input and Output Levels

VIL		VIH		VOL	VOH	IOL	IOH
Min. V	Max. V	Min. V	Max. V	Max. V	Min. V	mA	mA
-0.3	0.7	1.7	3.6	0.40	2.0	12	-12

AC Loadings

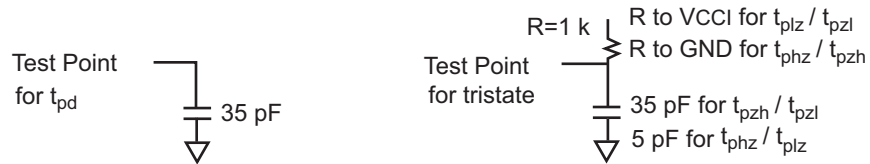

Figure 2-16 • AC Test Loads

Table 2-27 • AC Waveforms, Measuring Points, and Capacitive Loads

Input Low (V)	Input High (V)	Measuring Point* (V)	VREF (typ) (V)	C _{load} (pF)
0	2.5	1.25	N/A	35

Note: *Measuring Point = V_{trip}

Timing Characteristics

Table 2-28 • Worst-Case Military Conditions VCCA = 1.425 V, VCCI = 2.3 V, T_J = 125°C

Parameter	Description	-1 Speed				Std. Speed		Units
		RTAX4000S/SL		RTAX250/1000/2000S/SL		All		
		Min.	Max.	Min.	Max.	Min.	Max.	
LVC MOS25 I/O Module Drive Strength = 1 (6 mA) / Low Slew Rate								
t _{DP}	Input buffer		2.26		2.13		2.51	ns
t _{PY}	Output buffer		22.98		21.66		25.46	ns
t _{ENZL}	Enable to Pad delay through the Output Buffer—Z to Low		24.20		22.81		26.81	ns
t _{ENZH}	Enable to Pad delay through the Output Buffer—Z to High		21.72		20.47		24.07	ns
t _{ENLZ}	Enable to Pad delay through the Output Buffer—Low to Z		7.13		6.72		7.90	ns
t _{ENHZ}	Enable to Pad delay through the Output Buffer—High to Z		8.19		7.72		9.07	ns
t _{IOCLKQ}	Sequential clock-to-Q for the input register		0.95		0.90		1.05	ns
t _{IOCLKY}	Clock-to-output Y for the I/O output register and the enable register		0.95		0.90		1.05	ns
t _{SUD}	Data input setup		0.33		0.31		0.36	ns
t _{SUE}	Enable input setup		0.36		0.34		0.40	ns
t _{HD}	Data input hold		0.00		0.00		0.00	ns
t _{HE}	Enable input hold		0.00		0.00		0.00	ns
t _{CPWHL}	Clock pulse width High to Low	0.39		0.39		0.39		ns
t _{CPWLH}	Clock pulse width Low to High	0.39		0.39		0.39		ns
t _{WASYN}	Asynchronous pulse width	0.37		0.37		0.37		ns
t _{REASYN}	Asynchronous recovery time		0.18		0.17		0.20	ns
t _{HASYN}	Asynchronous removal time		0.00		0.00		0.00	ns
t _{CLR}	Asynchronous Clear-to-Q		0.33		0.31		0.37	ns
t _{PRESET}	Asynchronous Preset-to-Q		0.33		0.31		0.37	ns

Table 2-28 • Worst-Case Military Conditions VCCA = 1.425 V, VCCI = 2.3 V, T_J = 125°C

Parameter	Description	-1 Speed				Std. Speed		Units
		RTAX4000S/SL		RTAX250/1000/2000S/SL		All		
		Min.	Max.	Min.	Max.	Min.	Max.	
LVC MOS25 I/O Module Drive Strength = 2 (12 mA) / Low Slew Rate								
t _{DP}	Input buffer		2.26		2.13		2.51	ns
t _{PY}	Output buffer		19.19		18.09		21.26	ns
t _{ENZL}	Enable to Pad delay through the Output Buffer—Z to Low		20.21		19.05		22.39	ns
t _{ENZH}	Enable to Pad delay through the Output Buffer—Z to High		18.47		17.40		20.46	ns
t _{ENLZ}	Enable to Pad delay through the Output Buffer—Low to Z		7.13		6.72		7.90	ns
t _{ENHZ}	Enable to Pad delay through the Output Buffer—High to Z		8.19		7.72		9.07	ns
t _{IOCLKQ}	Sequential clock-to-Q for the input register		0.95		0.90		1.05	ns
t _{IOCLKY}	Clock-to-output Y for the I/O output register and the enable register		0.95		0.90		1.05	ns
t _{SUD}	Data input setup		0.33		0.31		0.36	ns
t _{SUE}	Enable input setup		0.36		0.34		0.40	ns
t _{HD}	Data input hold		0.00		0.00		0.00	ns
t _{HE}	Enable input hold		0.00		0.00		0.00	ns
t _{CPWHL}	Clock pulse width High to Low	0.39		0.39		0.39		ns
t _{CPWLH}	Clock pulse width Low to High	0.39		0.39		0.39		ns
t _{WASYN}	Asynchronous pulse width	0.37		0.37		0.37		ns
t _{REASYN}	Asynchronous recovery time		0.18		0.17		0.20	ns
t _{HASYN}	Asynchronous removal time		0.00		0.00		0.00	ns
t _{CLR}	Asynchronous Clear-to-Q		0.33		0.31		0.37	ns
t _{PRESET}	Asynchronous Preset-to-Q		0.33		0.31		0.37	ns

Table 2-28 • Worst-Case Military Conditions VCCA = 1.425 V, VCCI = 2.3 V, T_J = 125°C

Parameter	Description	-1 Speed				Std. Speed		Units
		RTAX4000S/SL		RTAX250/1000/2000S/SL		All		
		Min.	Max.	Min.	Max.	Min.	Max.	
LVC MOS25 I/O Module Drive Strength = 3 (16 mA) / Low Slew Rate								
t _{DP}	Input buffer		2.26		2.13		2.51	ns
t _{PY}	Output buffer		17.63		16.62		19.53	ns
t _{ENZL}	Enable to Pad delay through the Output Buffer—Z to Low		18.56		17.50		20.57	ns
t _{ENZH}	Enable to Pad delay through the Output Buffer—Z to High		16.81		15.84		18.62	ns
t _{ENLZ}	Enable to Pad delay through the Output Buffer—Low to Z		7.13		6.72		7.90	ns
t _{ENHZ}	Enable to Pad delay through the Output Buffer—High to Z		8.19		7.72		9.07	ns
t _{IOCLKQ}	Sequential clock-to-Q for the input register		0.95		0.90		1.05	ns
t _{IOCLKY}	Clock-to-output Y for the I/O output register and the enable register		0.95		0.90		1.05	ns
t _{SUD}	Data input setup		0.33		0.31		0.36	ns
t _{SUE}	Enable input setup		0.36		0.34		0.40	ns
t _{HD}	Data input hold		0.00		0.00		0.00	ns
t _{HE}	Enable input hold		0.00		0.00		0.00	ns
t _{CPWHL}	Clock pulse width High to Low	0.39		0.39		0.39		ns
t _{CPWLH}	Clock pulse width Low to High	0.39		0.39		0.39		ns
t _{WASYN}	Asynchronous pulse width	0.37		0.37		0.37		ns
t _{REASYN}	Asynchronous recovery time		0.18		0.17		0.20	ns
t _{HASYN}	Asynchronous removal time		0.00		0.00		0.00	ns
t _{CLR}	Asynchronous Clear-to-Q		0.33		0.31		0.37	ns
t _{PRESET}	Asynchronous Preset-to-Q		0.33		0.31		0.37	ns

Table 2-28 • Worst-Case Military Conditions VCCA = 1.425 V, VCCI = 2.3 V, T_J = 125°C

Parameter	Description	-1 Speed				Std. Speed		Units
		RTAX4000S/SL		RTAX250/1000/2000S/SL		All		
		Min.	Max.	Min.	Max.	Min.	Max.	
LVC MOS25 I/O Module Drive Strength = 4 (24 mA) / Low Slew Rate								
t _{DP}	Input buffer		2.26		2.13		2.51	ns
t _{PY}	Output buffer		16.62		15.66		18.41	ns
t _{ENZL}	Enable to Pad delay through the Output Buffer—Z to Low		17.49		16.49		19.38	ns
t _{ENZH}	Enable to Pad delay through the Output Buffer—Z to High		16.01		15.09		17.74	ns
t _{ENLZ}	Enable to Pad delay through the Output Buffer—Low to Z		7.13		6.72		7.90	ns
t _{ENHZ}	Enable to Pad delay through the Output Buffer—High to Z		8.19		7.72		9.07	ns
t _{IOCLKQ}	Sequential clock-to-Q for the input register		0.95		0.90		1.05	ns
t _{IOCLKY}	Clock-to-output Y for the I/O output register and the enable register		0.95		0.90		1.05	ns
t _{SUD}	Data input setup		0.33		0.31		0.36	ns
t _{SUE}	Enable input setup		0.36		0.34		0.40	ns
t _{HD}	Data input hold		0.00		0.00		0.00	ns
t _{HE}	Enable input hold		0.00		0.00		0.00	ns
t _{CPWHL}	Clock pulse width High to Low	0.39		0.39		0.39		ns
t _{CPWLH}	Clock pulse width Low to High	0.39		0.39		0.39		ns
t _{WASYN}	Asynchronous pulse width	0.37		0.37		0.37		ns
t _{REASYN}	Asynchronous recovery time		0.18		0.17		0.20	ns
t _{HASYN}	Asynchronous removal time		0.00		0.00		0.00	ns
t _{CLR}	Asynchronous Clear-to-Q		0.33		0.31		0.37	ns
t _{PRESET}	Asynchronous Preset-to-Q		0.33		0.31		0.37	ns

Table 2-28 • Worst-Case Military Conditions VCCA = 1.425 V, VCCI = 2.3 V, T_J = 125°C

Parameter	Description	-1 Speed				Std. Speed		Units
		RTAX4000S/SL		RTAX250/1000/2000S/SL		All		
		Min.	Max.	Min.	Max.	Min.	Max.	
LVC MOS25 I/O Module Drive Strength = 1 (6 mA) / High Slew Rate								
t _{DP}	Input buffer		2.26		2.13		2.51	ns
t _{py}	Output buffer		6.71		6.32		7.43	ns
t _{ENZL}	Enable to Pad delay through the Output Buffer—Z to Low		5.60		5.27		6.20	ns
t _{ENZH}	Enable to Pad delay through the Output Buffer—Z to High		6.71		6.32		7.43	ns
t _{ENLZ}	Enable to Pad delay through the Output Buffer—Low to Z		7.13		6.72		7.90	ns
t _{ENHZ}	Enable to Pad delay through the Output Buffer—High to Z		8.19		7.72		9.07	ns
t _{IOCLKQ}	Sequential clock-to-Q for the input register		0.95		0.90		1.05	ns
t _{IOCLKY}	Clock-to-output Y for the I/O output register and the enable register		0.95		0.90		1.05	ns
t _{SUD}	Data input setup		0.33		0.31		0.36	ns
t _{SUE}	Enable input setup		0.36		0.34		0.40	ns
t _{HD}	Data input hold		0.00		0.00		0.00	ns
t _{HE}	Enable input hold		0.00		0.00		0.00	ns
t _{CPWHL}	Clock pulse width High to Low	0.39		0.39		0.39		ns
t _{CPWLH}	Clock pulse width Low to High	0.39		0.39		0.39		ns
t _{WASYN}	Asynchronous pulse width	0.37		0.37		0.37		ns
t _{REASYN}	Asynchronous recovery time		0.18		0.17		0.20	ns
t _{HASYN}	Asynchronous removal time		0.00		0.00		0.00	ns
t _{CLR}	Asynchronous Clear-to-Q		0.33		0.31		0.37	ns
t _{PRESET}	Asynchronous Preset-to-Q		0.33		0.31		0.37	ns

Table 2-28 • Worst-Case Military Conditions VCCA = 1.425 V, VCCI = 2.3 V, T_J = 125°C

Parameter	Description	-1 Speed				Std. Speed		Units
		RTAX4000S/SL		RTAX250/1000/2000S/SL		All		
		Min.	Max.	Min.	Max.	Min.	Max.	
LVC MOS25 I/O Module Drive Strength = 2 (12 mA) / High Slew Rate								
t _{DP}	Input buffer		2.26		2.13		2.51	ns
t _{py}	Output buffer		4.70		4.43		5.21	ns
t _{ENZL}	Enable to Pad delay through the Output Buffer—Z to Low		4.34		4.09		4.80	ns
t _{ENZH}	Enable to Pad delay through the Output Buffer—Z to High		4.70		4.43		5.21	ns
t _{ENLZ}	Enable to Pad delay through the Output Buffer—Low to Z		7.13		6.72		7.90	ns
t _{ENHZ}	Enable to Pad delay through the Output Buffer—High to Z		8.19		7.72		9.07	ns
t _{IOCLKQ}	Sequential clock-to-Q for the input register		0.95		0.90		1.05	ns
t _{IOCLKY}	Clock-to-output Y for the I/O output register and the enable register		0.95		0.90		1.05	ns
t _{SUD}	Data input setup		0.33		0.31		0.36	ns
t _{SUE}	Enable input setup		0.36		0.34		0.40	ns
t _{HD}	Data input hold		0.00		0.00		0.00	ns
t _{HE}	Enable input hold		0.00		0.00		0.00	ns
t _{CPWHL}	Clock pulse width High to Low	0.39		0.39		0.39		ns
t _{CPWLH}	Clock pulse width Low to High	0.39		0.39		0.39		ns
t _{WASYN}	Asynchronous pulse width	0.37		0.37		0.37		ns
t _{REASYN}	Asynchronous recovery time		0.18		0.17		0.20	ns
t _{HASYN}	Asynchronous removal time		0.00		0.00		0.00	ns
t _{CLR}	Asynchronous Clear-to-Q		0.33		0.31		0.37	ns
t _{PRESET}	Asynchronous Preset-to-Q		0.33		0.31		0.37	ns

Table 2-28 • Worst-Case Military Conditions VCCA = 1.425 V, VCCI = 2.3 V, T_J = 125°C

Parameter	Description	-1 Speed				Std. Speed		Units
		RTAX4000S/SL		RTAX250/1000/2000S/SL		All		
		Min.	Max.	Min.	Max.	Min.	Max.	
LVC MOS25 I/O Module Drive Strength = 3 (16 mA) / High Slew Rate								
t _{DP}	Input buffer		2.26		2.13		2.51	ns
t _{py}	Output buffer		4.14		3.91		4.59	ns
t _{ENZL}	Enable to Pad delay through the Output Buffer—Z to Low		4.09		3.86		4.53	ns
t _{ENZH}	Enable to Pad delay through the Output Buffer—Z to High		4.14		3.91		4.59	ns
t _{ENLZ}	Enable to Pad delay through the Output Buffer—Low to Z		7.13		6.72		7.90	ns
t _{ENHZ}	Enable to Pad delay through the Output Buffer—High to Z		8.19		7.72		9.07	ns
t _{IOCLKQ}	Sequential clock-to-Q for the input register		0.95		0.90		1.05	ns
t _{IOCLKY}	Clock-to-output Y for the I/O output register and the enable register		0.95		0.90		1.05	ns
t _{SUD}	Data input setup		0.33		0.31		0.36	ns
t _{SUE}	Enable input setup		0.36		0.34		0.40	ns
t _{HD}	Data input hold		0.00		0.00		0.00	ns
t _{HE}	Enable input hold		0.00		0.00		0.00	ns
t _{CPWHL}	Clock pulse width High to Low	0.39		0.39		0.39		ns
t _{CPWLH}	Clock pulse width Low to High	0.39		0.39		0.39		ns
t _{WASYN}	Asynchronous pulse width	0.37		0.37		0.37		ns
t _{REASYN}	Asynchronous recovery time		0.18		0.17		0.20	ns
t _{HASYN}	Asynchronous removal time		0.00		0.00		0.00	ns
t _{CLR}	Asynchronous Clear-to-Q		0.33		0.31		0.37	ns
t _{PRESET}	Asynchronous Preset-to-Q		0.33		0.31		0.37	ns

Table 2-28 • Worst-Case Military Conditions VCCA = 1.425 V, VCCI = 2.3 V, T_J = 125°C

Parameter	Description	-1 Speed				Std. Speed		Units
		RTAX4000S/SL		RTAX250/1000/2000S/SL		All		
		Min.	Max.	Min.	Max.	Min.	Max.	
LVC MOS25 I/O Module Drive Strength = 4 (24 mA) / High Slew Rate								
t _{DP}	Input buffer		2.26		2.13		2.51	ns
t _{py}	Output buffer		3.81		3.59		4.22	ns
t _{ENZL}	Enable to Pad delay through the Output Buffer—Z to Low		3.88		3.66		4.30	ns
t _{ENZH}	Enable to Pad delay through the Output Buffer—Z to High		3.81		3.59		4.22	ns
t _{ENLZ}	Enable to Pad delay through the Output Buffer—Low to Z		7.13		6.72		7.90	ns
t _{ENHZ}	Enable to Pad delay through the Output Buffer—High to Z		8.19		7.72		9.07	ns
t _{IOCLKQ}	Sequential clock-to-Q for the input register		0.95		0.90		1.05	ns
t _{IOCLKY}	Clock-to-output Y for the I/O output register and the enable register		0.95		0.90		1.05	ns
t _{SUD}	Data input setup		0.33		0.31		0.36	ns
t _{SUE}	Enable input setup		0.36		0.34		0.40	ns
t _{HD}	Data input hold		0.00		0.00		0.00	ns
t _{HE}	Enable input hold		0.00		0.00		0.00	ns
t _{CPWHL}	Clock pulse width High to Low	0.39		0.39		0.39		ns
t _{CPWLH}	Clock pulse width Low to High	0.39		0.39		0.39		ns
t _{WASYN}	Asynchronous pulse width	0.37		0.37		0.37		ns
t _{REASYN}	Asynchronous recovery time		0.18		0.17		0.20	ns
t _{HASYN}	Asynchronous removal time		0.00		0.00		0.00	ns
t _{CLR}	Asynchronous Clear-to-Q		0.33		0.31		0.37	ns
t _{PRESET}	Asynchronous Preset-to-Q		0.33		0.31		0.37	ns

1.8 V LVCMOS

Low-Voltage Complementary Metal-Oxide Semiconductor for 1.8 V is an extension of the LVCMOS standard (JESD8-5) used for general-purpose 1.8 V applications. It uses a 3.3 V tolerant CMOS input buffer and a push-pull output buffer.

Table 2-29 • DC Input and Output Levels

VIL		VIH		VOL	VOH	IOL	IOH
Min. V	Max. V	Min. V	Max. V	Max. V	Min. V	mA	mA
-0.3	0.35* VCCI	0.65* VCCI	3.60	0.20	VCCI - 0.2	8	-8

AC Loadings

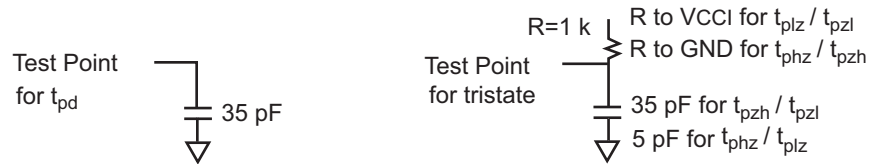

Figure 2-17 • AC Test Loads

Table 2-30 • AC Waveforms, Measuring Points, and Capacitive Loads

Input Low (V)	Input High (V)	Measuring Point* (V)	V _{REF} (typ) (V)	C _{load} (pF)
0	1.8	0.5VCCI	N/A	35.00

Note: *Measuring Point = V_{trip}

Timing Characteristics

Table 2-31 • Worst-Case Military Conditions VCCA = 1.425 V, VCCI = 1.7 V, T_J = 125°C

Parameter	Description	-1 Speed				Std. Speed		Units
		RTAX4000S/SL		RTAX250/1000/2000S/SL		All		
		Min.	Max.	Min.	Max.	Min.	Max.	
LVC MOS18 I/O Module Drive Strength = 2 (2 mA) / Low Slew Rate								
t _{DP}	Input buffer		3.78		3.56		4.19	ns
t _{PY}	Output buffer		35.85		33.79		39.72	ns
t _{ENZL}	Enable to Pad delay through the Output Buffer—Z to Low		37.75		35.58		41.82	ns
t _{ENZH}	Enable to Pad delay through the Output Buffer—Z to High		28.28		26.65		31.33	ns
t _{ENLZ}	Enable to Pad delay through the Output Buffer—Low to Z		7.47		7.04		8.27	ns
t _{ENHZ}	Enable to Pad delay through the Output Buffer—High to Z		8.36		7.88		9.26	ns
t _{IOCLKQ}	Sequential clock-to-Q for the input register		0.95		0.90		1.05	ns
t _{IOCLKY}	Clock-to-output Y for the I/O output register and the enable register		0.95		0.90		1.05	ns
t _{SUD}	Data input setup		0.33		0.31		0.36	ns
t _{SUE}	Enable input setup		0.36		0.34		0.40	ns
t _{HD}	Data input hold		0.00		0.00		0.00	ns
t _{HE}	Enable input hold		0.00		0.00		0.00	ns
t _{CPWHL}	Clock pulse width High to Low	0.39		0.39		0.39		ns
t _{CPWLH}	Clock pulse width Low to High	0.39		0.39		0.39		ns
t _{WASYN}	Asynchronous pulse width	0.37		0.37		0.37		ns
t _{REASYN}	Asynchronous recovery time		0.18		0.17		0.20	ns
t _{HASYN}	Asynchronous removal time		0.00		0.00		0.00	ns
t _{CLR}	Asynchronous Clear-to-Q		0.33		0.31		0.37	ns
t _{PRESET}	Asynchronous Preset-to-Q		0.33		0.31		0.37	ns

Table 2-31 • Worst-Case Military Conditions VCCA = 1.425 V, VCCI = 1.7 V, T_J = 125°C (continued)

Parameter	Description	-1 Speed				Std. Speed		Units
		RTAX4000S/SL		RTAX250/1000/2000S/SL		All		
		Min.	Max.	Min.	Max.	Min.	Max.	
LVC MOS18 I/O Module Drive Strength = 3 (6 mA) / Low Slew Rate								
t _{DP}	Input buffer		3.78		3.56		4.19	ns
t _{PY}	Output buffer		32.95		31.06		36.51	ns
t _{ENZL}	Enable to Pad delay through the Output Buffer—Z to Low		34.70		32.70		38.44	ns
t _{ENZH}	Enable to Pad delay through the Output Buffer—Z to High		25.80		24.32		28.59	ns
t _{ENLZ}	Enable to Pad delay through the Output Buffer—Low to Z		7.47		7.04		8.27	ns
t _{ENHZ}	Enable to Pad delay through the Output Buffer—High to Z		8.36		7.88		9.26	ns
t _{IOCLKQ}	Sequential clock-to-Q for the input register		0.95		0.90		1.05	ns
t _{IOCLKY}	Clock-to-output Y for the I/O output register and the enable register		0.95		0.90		1.05	ns
t _{SUD}	Data input setup		0.33		0.31		0.36	ns
t _{SUE}	Enable input setup		0.36		0.34		0.40	ns
t _{HD}	Data input hold		0.00		0.00		0.00	ns
t _{HE}	Enable input hold		0.00		0.00		0.00	ns
t _{CPWHL}	Clock pulse width High to Low	0.39		0.39		0.39		ns
t _{CPWLH}	Clock pulse width Low to High	0.39		0.39		0.39		ns
t _{WASYN}	Asynchronous pulse width	0.37		0.37		0.37		ns
t _{REASYN}	Asynchronous recovery time		0.18		0.17		0.20	ns
t _{HASYN}	Asynchronous removal time		0.00		0.00		0.00	ns
t _{CLR}	Asynchronous Clear-to-Q		0.33		0.31		0.37	ns
t _{PRESET}	Asynchronous Preset-to-Q		0.33		0.31		0.37	ns

Table 2-31 • Worst-Case Military Conditions VCCA = 1.425 V, VCCI = 1.7 V, T_J = 125°C (continued)

Parameter	Description	-1 Speed				Std. Speed		Units
		RTAX4000S/SL		RTAX250/1000/2000S/SL		All		
		Min.	Max.	Min.	Max.	Min.	Max.	
LVC MOS18 I/O Module Drive Strength = 4 (8 mA) / Low Slew Rate								
t _{DP}	Input buffer		3.78		3.56		4.19	ns
t _{PY}	Output buffer		31.55		29.73		34.95	ns
t _{ENZL}	Enable to Pad delay through the Output Buffer—Z to Low		33.22		31.31		36.80	ns
t _{ENZH}	Enable to Pad delay through the Output Buffer—Z to High		24.65		23.23		27.31	ns
t _{ENLZ}	Enable to Pad delay through the Output Buffer—Low to Z		7.47		7.04		8.27	ns
t _{ENHZ}	Enable to Pad delay through the Output Buffer—High to Z		8.36		7.88		9.26	ns
t _{IOCLKQ}	Sequential clock-to-Q for the input register		0.95		0.90		1.05	ns
t _{IOCLKY}	Clock-to-output Y for the I/O output register and the enable register		0.95		0.90		1.05	ns
t _{SUD}	Data input setup		0.33		0.31		0.36	ns
t _{SUE}	Enable input setup		0.36		0.34		0.40	ns
t _{HD}	Data input hold		0.00		0.00		0.00	ns
t _{HE}	Enable input hold		0.00		0.00		0.00	ns
t _{CPWHL}	Clock pulse width High to Low	0.39		0.39		0.39		ns
t _{CPWLH}	Clock pulse width Low to High	0.39		0.39		0.39		ns
t _{WASYN}	Asynchronous pulse width	0.37		0.37		0.37		ns
t _{REASYN}	Asynchronous recovery time		0.18		0.17		0.20	ns
t _{HASYN}	Asynchronous removal time		0.00		0.00		0.00	ns
t _{CLR}	Asynchronous Clear-to-Q		0.33		0.31		0.37	ns
t _{PRESET}	Asynchronous Preset-to-Q		0.33		0.31		0.37	ns

Table 2-31 • Worst-Case Military Conditions VCCA = 1.425 V, VCCI = 1.7 V, T_J = 125°C (continued)

Parameter	Description	-1 Speed				Std. Speed		Units
		RTAX4000S/SL		RTAX250/1000/2000S/SL		All		
		Min.	Max.	Min.	Max.	Min.	Max.	
LVC MOS18 I/O Module Drive Strength = 2 (2 mA) / High Slew Rate								
t _{DP}	Input buffer		3.78		3.56		4.19	ns
t _{PY}	Output buffer		6.94		6.54		7.69	ns
t _{ENZL}	Enable to Pad delay through the Output Buffer—Z to Low		5.09		4.80		5.64	ns
t _{ENZH}	Enable to Pad delay through the Output Buffer—Z to High		6.94		6.54		7.69	ns
t _{ENLZ}	Enable to Pad delay through the Output Buffer—Low to Z		7.47		7.04		8.27	ns
t _{ENHZ}	Enable to Pad delay through the Output Buffer—High to Z		8.36		7.88		9.26	ns
t _{IOCLKQ}	Sequential clock-to-Q for the input register		0.95		0.90		1.05	ns
t _{IOCLKY}	Clock-to-output Y for the I/O output register and the enable register		0.95		0.90		1.05	ns
t _{SUD}	Data input setup		0.33		0.31		0.36	ns
t _{SUE}	Enable input setup		0.36		0.34		0.40	ns
t _{HD}	Data input hold		0.00		0.00		0.00	ns
t _{HE}	Enable input hold		0.00		0.00		0.00	ns
t _{CPWHL}	Clock pulse width High to Low	0.39		0.39		0.39		ns
t _{CPWLH}	Clock pulse width Low to High	0.39		0.39		0.39		ns
t _{WASYN}	Asynchronous pulse width	0.37		0.37		0.37		ns
t _{REASYN}	Asynchronous recovery time		0.18		0.17		0.20	ns
t _{HASYN}	Asynchronous removal time		0.00		0.00		0.00	ns
t _{CLR}	Asynchronous Clear-to-Q		0.33		0.31		0.37	ns
t _{PRESET}	Asynchronous Preset-to-Q		0.33		0.31		0.37	ns

Table 2-31 • Worst-Case Military Conditions VCCA = 1.425 V, VCCI = 1.7 V, T_J = 125°C (continued)

Parameter	Description	-1 Speed				Std. Speed		Units
		RTAX4000S/SL		RTAX250/1000/2000S/SL		All		
		Min.	Max.	Min.	Max.	Min.	Max.	
LVC MOS18 I/O Module Drive Strength = 3 (6 mA) / High Slew Rate								
t _{DP}	Input buffer		3.78		3.56		4.19	ns
t _{py}	Output buffer		5.89		5.55		6.52	ns
t _{ENZL}	Enable to Pad delay through the Output Buffer—Z to Low		4.74		4.47		5.25	ns
t _{ENZH}	Enable to Pad delay through the Output Buffer—Z to High		5.89		5.55		6.52	ns
t _{ENLZ}	Enable to Pad delay through the Output Buffer—Low to Z		7.47		7.04		8.27	ns
t _{ENHZ}	Enable to Pad delay through the Output Buffer—High to Z		8.36		7.88		9.26	ns
t _{iOCLKQ}	Sequential clock-to-Q for the input register		0.95		0.90		1.05	ns
t _{iOCLKY}	Clock-to-output Y for the I/O output register and the enable register		0.95		0.90		1.05	ns
t _{SUD}	Data input setup		0.33		0.31		0.36	ns
t _{SUE}	Enable input setup		0.36		0.34		0.40	ns
t _{HD}	Data input hold		0.00		0.00		0.00	ns
t _{HE}	Enable input hold		0.00		0.00		0.00	ns
t _{CPWHL}	Clock pulse width High to Low	0.39		0.39		0.39		ns
t _{CPWLH}	Clock pulse width Low to High	0.39		0.39		0.39		ns
t _{WASYN}	Asynchronous pulse width	0.37		0.37		0.37		ns
t _{REASYN}	Asynchronous recovery time		0.18		0.17		0.20	ns
t _{HASYN}	Asynchronous removal time		0.00		0.00		0.00	ns
t _{CLR}	Asynchronous Clear-to-Q		0.33		0.31		0.37	ns
t _{PRESET}	Asynchronous Preset-to-Q		0.33		0.31		0.37	ns

Table 2-31 • Worst-Case Military Conditions VCCA = 1.425 V, VCCI = 1.7 V, T_J = 125°C (continued)

Parameter	Description	-1 Speed				Std. Speed		Units
		RTAX4000S/SL		RTAX250/1000/2000S/SL		All		
		Min.	Max.	Min.	Max.	Min.	Max.	
LVC MOS18 I/O Module Drive Strength = 4 (8 mA) / High Slew Rate								
t _{DP}	Input buffer		3.78		3.56		4.19	ns
t _{PY}	Output buffer		5.27		4.97		5.84	ns
t _{ENZL}	Enable to Pad delay through the Output Buffer—Z to Low		4.40		4.15		4.88	ns
t _{ENZH}	Enable to Pad delay through the Output Buffer—Z to High		5.27		4.97		5.84	ns
t _{ENLZ}	Enable to Pad delay through the Output Buffer—Low to Z		7.47		7.04		8.27	ns
t _{ENHZ}	Enable to Pad delay through the Output Buffer—High to Z		8.36		7.88		9.26	ns
t _{IOCLKQ}	Sequential clock-to-Q for the input register		0.95		0.90		1.05	ns
t _{IOCLKY}	Clock-to-output Y for the I/O output register and the enable register		0.95		0.90		1.05	ns
t _{SUD}	Data input setup		0.33		0.31		0.36	ns
t _{SUE}	Enable input setup		0.36		0.34		0.40	ns
t _{HD}	Data input hold		0.00		0.00		0.00	ns
t _{HE}	Enable input hold		0.00		0.00		0.00	ns
t _{CPWHL}	Clock pulse width High to Low	0.39		0.39		0.39		ns
t _{CPWLH}	Clock pulse width Low to High	0.39		0.39		0.39		ns
t _{WASYN}	Asynchronous pulse width	0.37		0.37		0.37		ns
t _{REASYN}	Asynchronous recovery time		0.18		0.17		0.20	ns
t _{HASYN}	Asynchronous removal time		0.00		0.00		0.00	ns
t _{CLR}	Asynchronous Clear-to-Q		0.33		0.31		0.37	ns
t _{PRESET}	Asynchronous Preset-to-Q		0.33		0.31		0.37	ns

1.5 V LVCMOS (JESD8-11)

Low-Voltage Complementary Metal-Oxide Semiconductor for 1.5 V is an extension of the LVCMOS standard (JESD8-5) used for general-purpose 1.5 V applications. It uses a 3.3 V tolerant CMOS input buffer and a push-pull output buffer.

Table 2-32 • DC Input and Output Levels

VIL		VIH		VOL	VOH	IOL	IOH
Min. V	Max. V	Min. V	Max. V	Max. V	Min. V	mA	mA
-0.3	0.35 VCCI	0.65 VCCI	3.60	0.40	VCCI - 0.4	8 mA	-8 mA

AC Loadings

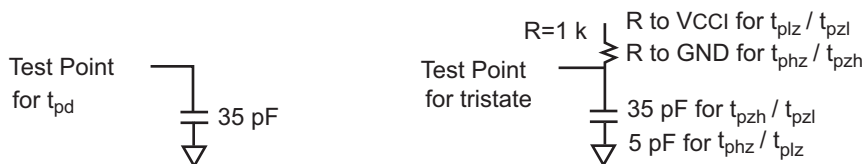

Figure 2-18 • AC Test Loads

Table 2-33 • AC Waveforms, Measuring Points, and Capacitive Loads

Input Low (V)	Input High (V)	Measuring Point* (V)	VREF (typ) (V)	C _{load} (pF)
0	1.5	0.5VCCI	N/A	35.00

Note: *Measuring Point = V_{trip}

Timing Characteristics

Table 2-34 • Worst-Case Military Conditions VCCA = 1.425 V, VCCI = 1.4 V, T_J = 125°C

Parameter	Description	-1 Speed				Std. Speed		Units
		RTAX4000S/SL		RTAX250/1000/2000S/SL		All		
		Min.	Max.	Min.	Max.	Min.	Max.	
LVC MOS15 I/O Module Drive Strength = 1 (2 mA) / Low Slew Rate								
t _{DP}	Input buffer		4.17		3.93		4.62	ns
t _{PY}	Output buffer		64.07		60.38		70.98	ns
t _{ENZL}	Enable to Pad delay through the Output Buffer—Z to Low		67.46		63.58		74.74	ns
t _{ENZH}	Enable to Pad delay through the Output Buffer—Z to High		47.54		44.80		52.67	ns
t _{ENLZ}	Enable to Pad delay through the Output Buffer—Low to Z		7.90		7.45		8.76	ns
t _{ENHZ}	Enable to Pad delay through the Output Buffer—High to Z		8.61		8.12		9.54	ns
t _{IOCLKQ}	Sequential clock-to-Q for the input register		0.95		0.90		1.05	ns
t _{IOCLKY}	Clock-to-output Y for the I/O output register and the enable register		0.95		0.90		1.05	ns
t _{SUD}	Data input setup		0.33		0.31		0.36	ns
t _{SUE}	Enable input setup		0.36		0.34		0.40	ns
t _{HD}	Data input hold		0.00		0.00		0.00	ns
t _{HE}	Enable input hold		0.00		0.00		0.00	ns
t _{CPWHL}	Clock pulse width High to Low	0.39		0.39		0.39		ns
t _{CPWLH}	Clock pulse width Low to High	0.39		0.39		0.39		ns
t _{WASYN}	Asynchronous pulse width	0.37		0.37		0.37		ns
t _{REASYN}	Asynchronous recovery time		0.18		0.17		0.20	ns
t _{HASYN}	Asynchronous removal time		0.00		0.00		0.00	ns
t _{CLR}	Asynchronous Clear-to-Q		0.33		0.31		0.37	ns
t _{PRESET}	Asynchronous Preset-to-Q		0.33		0.31		0.37	ns

Table 2-34 • Worst-Case Military Conditions VCCA = 1.425 V, VCCI = 1.4 V, T_J = 125°C

Parameter	Description	-1 Speed				Std. Speed		Units
		RTAX4000S/SL		RTAX250/1000/2000S/SL		All		
		Min.	Max.	Min.	Max.	Min.	Max.	
LVC MOS15 I/O Module Drive Strength = 2 (4 mA) / Low Slew Rate								
t _{DP}	Input buffer		4.17		3.93		4.62	ns
t _{py}	Output buffer		56.55		53.29		62.65	ns
t _{ENZL}	Enable to Pad delay through the Output Buffer—Z to Low		59.55		56.12		65.97	ns
t _{ENZH}	Enable to Pad delay through the Output Buffer—Z to High		40.20		37.88		44.53	ns
t _{ENLZ}	Enable to Pad delay through the Output Buffer—Low to Z		7.90		7.45		8.76	ns
t _{ENHZ}	Enable to Pad delay through the Output Buffer—High to Z		8.61		8.12		9.54	ns
t _{iOCLKQ}	Sequential clock-to-Q for the input register		0.95		0.90		1.05	ns
t _{iOCLKY}	Clock-to-output Y for the I/O output register and the enable register		0.95		0.90		1.05	ns
t _{SUD}	Data input setup		0.33		0.31		0.36	ns
t _{SUE}	Enable input setup		0.36		0.34		0.40	ns
t _{HD}	Data input hold		0.00		0.00		0.00	ns
t _{HE}	Enable input hold		0.00		0.00		0.00	ns
t _{CPWHL}	Clock pulse width High to Low	0.39		0.39		0.39		ns
t _{CPWLH}	Clock pulse width Low to High	0.39		0.39		0.39		ns
t _{WASYN}	Asynchronous pulse width	0.37		0.37		0.37		ns
t _{REASYN}	Asynchronous recovery time		0.18		0.17		0.20	ns
t _{HASYN}	Asynchronous removal time		0.00		0.00		0.00	ns
t _{CLR}	Asynchronous Clear-to-Q		0.33		0.31		0.37	ns
t _{PRESET}	Asynchronous Preset-to-Q		0.33		0.31		0.37	ns

Table 2-34 • Worst-Case Military Conditions VCCA = 1.425 V, VCCI = 1.4 V, T_J = 125°C

Parameter	Description	-1 Speed				Std. Speed		Units
		RTAX4000S/SL		RTAX250/1000/2000S/SL		All		
		Min.	Max.	Min.	Max.	Min.	Max.	
LVC MOS15 I/O Module Drive Strength = 3 (6 mA) / Low Slew Rate								
t _{DP}	Input buffer		4.17		3.93		4.62	ns
t _{py}	Output buffer		51.89		48.90		57.49	ns
t _{ENZL}	Enable to Pad delay through the Output Buffer—Z to Low		54.64		51.50		60.54	ns
t _{ENZH}	Enable to Pad delay through the Output Buffer—Z to High		36.96		34.84		40.95	ns
t _{ENLZ}	Enable to Pad delay through the Output Buffer—Low to Z		7.90		7.45		8.76	ns
t _{ENHZ}	Enable to Pad delay through the Output Buffer—High to Z		8.61		8.12		9.54	ns
t _{iOCLKQ}	Sequential clock-to-Q for the input register		0.95		0.90		1.05	ns
t _{iOCLKY}	Clock-to-output Y for the I/O output register and the enable register		0.95		0.90		1.05	ns
t _{SUD}	Data input setup		0.33		0.31		0.36	ns
t _{SUE}	Enable input setup		0.36		0.34		0.40	ns
t _{HD}	Data input hold		0.00		0.00		0.00	ns
t _{HE}	Enable input hold		0.00		0.00		0.00	ns
t _{CPWHL}	Clock pulse width High to Low	0.39		0.39		0.39		ns
t _{CPWLH}	Clock pulse width Low to High	0.39		0.39		0.39		ns
t _{WASYN}	Asynchronous pulse width	0.37		0.37		0.37		ns
t _{REASYN}	Asynchronous recovery time		0.18		0.17		0.20	ns
t _{HASYN}	Asynchronous removal time		0.00		0.00		0.00	ns
t _{CLR}	Asynchronous Clear-to-Q		0.33		0.31		0.37	ns
t _{PRESET}	Asynchronous Preset-to-Q		0.33		0.31		0.37	ns

Table 2-34 • Worst-Case Military Conditions VCCA = 1.425 V, VCCI = 1.4 V, T_J = 125°C

Parameter	Description	-1 Speed				Std. Speed		Units
		RTAX4000S/SL		RTAX250/1000/2000S/SL		All		
		Min.	Max.	Min.	Max.	Min.	Max.	
LVC MOS15 I/O Module Drive Strength = 8 (4 mA) / Low Slew Rate								
t _{DP}	Input buffer		4.17		3.93		4.62	ns
t _{py}	Output buffer		50.09		47.20		55.49	ns
t _{ENZL}	Enable to Pad delay through the Output Buffer—Z to Low		52.74		49.71		58.43	ns
t _{ENZH}	Enable to Pad delay through the Output Buffer—Z to High		35.21		33.18		39.01	ns
t _{ENLZ}	Enable to Pad delay through the Output Buffer—Low to Z		7.90		7.45		8.76	ns
t _{ENHZ}	Enable to Pad delay through the Output Buffer—High to Z		8.61		8.12		9.54	ns
t _{iOCLKQ}	Sequential clock-to-Q for the input register		0.95		0.90		1.05	ns
t _{iOCLKY}	Clock-to-output Y for the I/O output register and the enable register		0.95		0.90		1.05	ns
t _{SUD}	Data input setup		0.33		0.31		0.36	ns
t _{SUE}	Enable input setup		0.36		0.34		0.40	ns
t _{HD}	Data input hold		0.00		0.00		0.00	ns
t _{HE}	Enable input hold		0.00		0.00		0.00	ns
t _{CPWHL}	Clock pulse width High to Low	0.39		0.39		0.39		ns
t _{CPWLH}	Clock pulse width Low to High	0.39		0.39		0.39		ns
t _{WASYN}	Asynchronous pulse width	0.37		0.37		0.37		ns
t _{REASYN}	Asynchronous recovery time		0.18		0.17		0.20	ns
t _{HASYN}	Asynchronous removal time		0.00		0.00		0.00	ns
t _{CLR}	Asynchronous Clear-to-Q		0.33		0.31		0.37	ns
t _{PRESET}	Asynchronous Preset-to-Q		0.33		0.31		0.37	ns

Table 2-34 • Worst-Case Military Conditions VCCA = 1.425 V, VCCI = 1.4 V, T_J = 125°C

Parameter	Description	-1 Speed				Std. Speed		Units
		RTAX4000S/SL		RTAX250/1000/2000S/SL		All		
		Min.	Max.	Min.	Max.	Min.	Max.	
LVC MOS15 I/O Module Drive Strength = 1 (2 mA) / High Slew Rate								
t _{DP}	Input buffer		4.17		3.93		4.62	ns
t _{py}	Output buffer		15.48		14.59		17.15	ns
t _{ENZL}	Enable to Pad delay through the Output Buffer—Z to Low		8.89		8.38		9.85	ns
t _{ENZH}	Enable to Pad delay through the Output Buffer—Z to High		15.48		14.59		17.15	ns
t _{ENLZ}	Enable to Pad delay through the Output Buffer—Low to Z		7.90		7.45		8.76	ns
t _{ENHZ}	Enable to Pad delay through the Output Buffer—High to Z		8.61		8.12		9.54	ns
t _{iOCLKQ}	Sequential clock-to-Q for the input register		0.95		0.90		1.05	ns
t _{iOCLKY}	Clock-to-output Y for the I/O output register and the enable register		0.95		0.90		1.05	ns
t _{SUD}	Data input setup		0.33		0.31		0.36	ns
t _{SUE}	Enable input setup		0.36		0.34		0.40	ns
t _{HD}	Data input hold		0.00		0.00		0.00	ns
t _{HE}	Enable input hold		0.00		0.00		0.00	ns
t _{CPWHL}	Clock pulse width High to Low	0.39		0.39		0.39		ns
t _{CPWLH}	Clock pulse width Low to High	0.39		0.39		0.39		ns
t _{WASYN}	Asynchronous pulse width	0.37		0.37		0.37		ns
t _{REASYN}	Asynchronous recovery time		0.18		0.17		0.20	ns
t _{HASYN}	Asynchronous removal time		0.00		0.00		0.00	ns
t _{CLR}	Asynchronous Clear-to-Q		0.33		0.31		0.37	ns
t _{PRESET}	Asynchronous Preset-to-Q		0.33		0.31		0.37	ns

Table 2-34 • Worst-Case Military Conditions VCCA = 1.425 V, VCCI = 1.4 V, T_J = 125°C

Parameter	Description	-1 Speed				Std. Speed		Units
		RTAX4000S/SL		RTAX250/1000/2000S/SL		All		
		Min.	Max.	Min.	Max.	Min.	Max.	
LVC MOS15 I/O Module Drive Strength = 2 (4 mA) / High Slew Rate								
t _{DP}	Input buffer		4.17		3.93		4.62	ns
t _{py}	Output buffer		9.68		9.12		10.73	ns
t _{ENZL}	Enable to Pad delay through the Output Buffer—Z to Low		6.14		5.79		6.81	ns
t _{ENZH}	Enable to Pad delay through the Output Buffer—Z to High		9.68		9.12		10.73	ns
t _{ENLZ}	Enable to Pad delay through the Output Buffer—Low to Z		7.90		7.45		8.76	ns
t _{ENHZ}	Enable to Pad delay through the Output Buffer—High to Z		8.61		8.12		9.54	ns
t _{iOCLKQ}	Sequential clock-to-Q for the input register		0.95		0.90		1.05	ns
t _{iOCLKY}	Clock-to-output Y for the I/O output register and the enable register		0.95		0.90		1.05	ns
t _{SUD}	Data input setup		0.33		0.31		0.36	ns
t _{SUE}	Enable input setup		0.36		0.34		0.40	ns
t _{HD}	Data input hold		0.00		0.00		0.00	ns
t _{HE}	Enable input hold		0.00		0.00		0.00	ns
t _{CPWHL}	Clock pulse width High to Low	0.39		0.39		0.39		ns
t _{CPWLH}	Clock pulse width Low to High	0.39		0.39		0.39		ns
t _{WASYN}	Asynchronous pulse width	0.37		0.37		0.37		ns
t _{REASYN}	Asynchronous recovery time		0.18		0.17		0.20	ns
t _{HASYN}	Asynchronous removal time		0.00		0.00		0.00	ns
t _{CLR}	Asynchronous Clear-to-Q		0.33		0.31		0.37	ns
t _{PRESET}	Asynchronous Preset-to-Q		0.33		0.31		0.37	ns

Table 2-34 • Worst-Case Military Conditions VCCA = 1.425 V, VCCI = 1.4 V, T_J = 125°C

Parameter	Description	-1 Speed				Std. Speed		Units
		RTAX4000S/SL		RTAX250/1000/2000S/SL		All		
		Min.	Max.	Min.	Max.	Min.	Max.	
LVC MOS15 I/O Module Drive Strength = 3 (6 mA) / High Slew Rate								
t _{DP}	Input buffer		4.17		3.93		4.62	ns
t _{py}	Output buffer		8.09		7.62		8.96	ns
t _{ENZL}	Enable to Pad delay through the Output Buffer—Z to Low		5.68		5.36		6.30	ns
t _{ENZH}	Enable to Pad delay through the Output Buffer—Z to High		8.09		7.62		8.96	ns
t _{ENLZ}	Enable to Pad delay through the Output Buffer—Low to Z		7.90		7.45		8.76	ns
t _{ENHZ}	Enable to Pad delay through the Output Buffer—High to Z		8.61		8.12		9.54	ns
t _{iOCLKQ}	Sequential clock-to-Q for the input register		0.95		0.90		1.05	ns
t _{iOCLKY}	Clock-to-output Y for the I/O output register and the enable register		0.95		0.90		1.05	ns
t _{SUD}	Data input setup		0.33		0.31		0.36	ns
t _{SUE}	Enable input setup		0.36		0.34		0.40	ns
t _{HD}	Data input hold		0.00		0.00		0.00	ns
t _{HE}	Enable input hold		0.00		0.00		0.00	ns
t _{CPWHL}	Clock pulse width High to Low	0.39		0.39		0.39		ns
t _{CPWLH}	Clock pulse width Low to High	0.39		0.39		0.39		ns
t _{WASYN}	Asynchronous pulse width	0.37		0.37		0.37		ns
t _{REASYN}	Asynchronous recovery time		0.18		0.17		0.20	ns
t _{HASYN}	Asynchronous removal time		0.00		0.00		0.00	ns
t _{CLR}	Asynchronous Clear-to-Q		0.33		0.31		0.37	ns
t _{PRESET}	Asynchronous Preset-to-Q		0.33		0.31		0.37	ns

Table 2-34 • Worst-Case Military Conditions VCCA = 1.425 V, VCCI = 1.4 V, T_J = 125°C

Parameter	Description	-1 Speed				Std. Speed		Units
		RTAX4000S/SL		RTAX250/1000/2000S/SL		All		
		Min.	Max.	Min.	Max.	Min.	Max.	
LVC MOS15 I/O Module Drive Strength = 4 (8 mA) / High Slew Rate								
t _{DP}	Input buffer		4.17		3.93		4.62	ns
t _{PY}	Output buffer		7.01		6.60		7.76	ns
t _{ENZL}	Enable to Pad delay through the Output Buffer—Z to Low		5.19		4.89		5.75	ns
t _{ENZH}	Enable to Pad delay through the Output Buffer—Z to High		7.01		6.60		7.76	ns
t _{ENLZ}	Enable to Pad delay through the Output Buffer—LOW to Z		7.90		7.45		8.76	ns
t _{ENHZ}	Enable to Pad delay through the Output Buffer—High to Z		8.61		8.12		9.54	ns
t _{IOCLKQ}	Sequential clock-to-Q for the input register		0.95		0.90		1.05	ns
t _{IOCLKY}	Clock-to-output Y for the I/O output register and the enable register		0.95		0.90		1.05	ns
t _{SUD}	Data input setup		0.33		0.31		0.36	ns
t _{SUE}	Enable input setup		0.36		0.34		0.40	ns
t _{HD}	Data input hold		0.00		0.00		0.00	ns
t _{HE}	Enable input hold		0.00		0.00		0.00	ns
t _{CPWHL}	Clock pulse width High to Low	0.39		0.39		0.39		ns
t _{CPWLH}	Clock pulse width Low to High	0.39		0.39		0.39		ns
t _{WASYN}	Asynchronous pulse width	0.37		0.37		0.37		ns
t _{REASYN}	Asynchronous recovery time		0.18		0.17		0.20	ns
t _{HASYN}	Asynchronous removal time		0.00		0.00		0.00	ns
t _{CLR}	Asynchronous Clear-to-Q		0.33		0.31		0.37	ns
t _{PRESET}	Asynchronous Preset-to-Q		0.33		0.31		0.37	ns

3.3 V PCI

Peripheral Component Interface for 3.3 V standard specifies support for 33 MHz and 66 MHz PCI bus applications. It uses an LVTTTL input buffer and a push-pull output buffer. The input and output buffers are 5 V tolerant with the aid of external components. The RTAX-S/SL 3.3 V PCI buffer is compliant with the PCI Local Bus Specification Rev. 2.1.

Table 2-35 • DC Input and Output Levels

VIL		VIH		VOL	VOH	IOL	IOH
Min. V	Max. V	Min. V	Max. V	Max. V	Min. V	mA	mA
-0.3	0.3 VCCI	0.5 VCCI	VCCI + 0.5	(per PCI specification)			

AC Loadings

Per PCI Specification except for tristate. Microsemi loading for tristate is in [Figure 2-19](#).

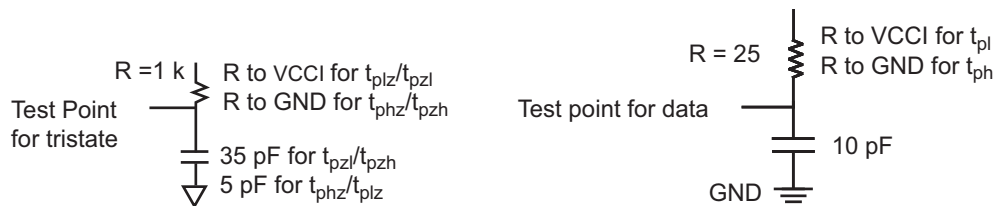

Figure 2-19 • AC Test Loads

Table 2-36 • AC Waveforms, Measuring Points, and Capacitive Loads

Input Low (V)	Input High (V)	Measuring Point* (V)	VREF (typ) (V)	C _{load} (pF)
(Per PCI Spec)			N/A	10

Note: *Measuring Point = V_{trip}

Timing Characteristics

Table 2-37 • Worst-Case Military Conditions VCCA = 1.425 V, VCCI = 3.0 V, T_J = 125°C

Parameter	Description	-1 Speed				Std. Speed		Units
		RTAX4000S/SL		RTAX250/1000/2000S/SL		All		
		Min.	Max.	Min.	Max.	Min.	Max.	
3.3V PCI I/O Module Timing								
t _{DP}	Input buffer		1.82		1.72		2.02	ns
t _{PY}	Output buffer		2.38		2.25		2.64	ns
t _{ENZL}	Enable to Pad delay through the Output Buffer—Z to Low		2.51		2.36		2.78	ns
t _{ENZH}	Enable to Pad delay through the Output Buffer—Z to High		2.23		2.10		2.47	ns
t _{ENLZ}	Enable to Pad delay through the Output Buffer—Low to Z		3.16		2.98		3.50	ns
t _{ENHZ}	Enable to Pad delay through the Output Buffer—High to Z		4.37		4.12		4.84	ns
t _{IOCLKQ}	Sequential clock-to-Q for the input register		0.95		0.90		1.05	ns
t _{IOCLKY}	Clock-to-output Y for the I/O output register and the enable register		0.95		0.90		1.05	ns
t _{SUD}	Data input setup		0.33		0.31		0.36	ns
t _{SUE}	Enable input setup		0.36		0.34		0.40	ns
t _{HD}	Data input hold		0.00		0.00		0.00	ns
t _{HE}	Enable input hold	0	0.00		0.00		0.00	ns
t _{CPWHL}	Clock pulse width High to Low	0.39		0.39		0.39		ns
t _{CPWLH}	Clock pulse width Low to High	0.39		0.39		0.39		ns
t _{WASYN}	Asynchronous pulse width	0.37		0.37		0.37		ns
t _{REASYN}	Asynchronous recovery time		0.18		0.17		0.20	ns
t _{HASYN}	Asynchronous removal time		0.00		0.00		0.00	ns
t _{CLR}	Asynchronous Clear-to-Q		0.33		0.31		0.37	ns
t _{PRESET}	Asynchronous Preset-to-Q		0.33		0.31		0.37	ns

Table 2-38 • Worst-Case Military Conditions VCCA = 1.425 V, VCCI = 3.0 V, T_J = 125°C

Parameter	Description	-1 Speed				Std. Speed		Units
		RTAX4000S/SL		RTAX250/1000/2000S/SL		All		
		Min.	Max.	Min.	Max.	Min.	Max.	
3.3 V PCI-X I/O Module Timing								
t _{DP}	Input buffer		1.82		1.72		2.02	ns
t _{PY}	Output buffer		2.44		2.30		2.71	ns
t _{ENZL}	Enable to Pad delay through the Output Buffer—Z to Low		2.51		2.36		2.78	ns
t _{ENZH}	Enable to Pad delay through the Output Buffer—Z to High		2.44		2.30		2.70	ns
t _{ENLZ}	Enable to Pad delay through the Output Buffer—Low to Z		3.29		3.10		3.65	ns
t _{ENHZ}	Enable to Pad delay through the Output Buffer—High to Z		3.87		3.64		4.28	ns
t _{IOCLKQ}	Sequential clock-to-Q for the input register		0.95		0.90		1.05	ns
t _{IOCLKY}	Clock-to-output Y for the I/O output register and the enable register		0.95		0.90		1.05	ns
t _{SUD}	Data input setup		0.33		0.31		0.36	ns
t _{SUE}	Enable input setup		0.36		0.34		0.40	ns
t _{HD}	Data input hold		0.00		0.00		0.00	ns
t _{HE}	Enable input hold		0.00		0.00		0.00	ns
t _{CPWHL}	Clock pulse width High to Low	0.39		0.39		0.39		ns
t _{CPWLH}	Clock pulse width Low to High	0.39		0.39		0.39		ns
t _{WASYN}	Asynchronous pulse width	0.37		0.37		0.37		ns
t _{REASYN}	Asynchronous recovery time		0.18		0.17		0.21	ns
t _{HASYN}	Asynchronous removal time		0.00		0.00		0.00	ns
t _{CLR}	Asynchronous Clear-to-Q		0.33		0.31		0.37	ns
t _{PRESET}	Asynchronous Preset-to-Q		0.33		0.31		0.37	ns

Voltage-Referenced I/O Standards

GTL+

Gunning Transceiver Logic Plus is a high-speed bus standard (JESD8-3). It requires a differential amplifier input buffer and an open drain output buffer. The VCCI pin should be connected to 2.5 V or 3.3 V. Note that 2.5 V GTL+ is not supported across the full military temperature range.

Table 2-39 • DC Input and Output Levels

VIL		VIH		VOL	VOH	IOL	IOH
Min. V	Max. V	Min. V	Max. V	Max. V	Min. V	mA	mA
N/A	VREF – 0.1	VREF + 0.1	N/A	0.6	NA	NA	NA

Note: For high temperature of 125°C only, VOL limits are 700 mV, for all other temperatures 600 mV applies.

AC Loadings

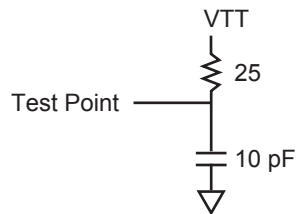

Figure 2-20 • AC Test Loads

Table 2-40 • AC Waveforms, Measuring Points, and Capacitive Loads

Input Low (V)	Input High (V)	Measuring Point* (V)	V _{REF} (typ) (V)	C _{load} (pF)
VREF-0.2	VREF+0.2	VREF	1.0	10

Note: *Measuring Point = V_{trip}

Timing Characteristics

Table 2-41 • Worst-Case Military Conditions VCCA = 1.425 V, VCCI = 3.0 V, T_J = 125°C

Parameter	Description	-1 Speed				'Std.' Speed		Units
		RTAX4000S/SL		RTAX250/1000/2000S/SL		All		
		Min.	Max.	Min.	Max.	Min.	Max.	
3.3 V GTL+ I/O Module Timing								
t _{DP}	Input buffer		2.13		2.01		2.36	ns
t _{PY}	Output buffer		1.34		1.26		1.49	ns
t _{iCLKQ}	Clock-to-Q for the I/O input register		0.95		0.90		1.05	ns
t _{OCLKQ}	Clock-to-Q for the I/O output register and the I/O enable register		0.95		0.90		1.05	ns
t _{SUD}	Data input setup		0.33		0.31		0.36	ns
t _{SUE}	Enable input setup		0.36		0.34		0.40	ns
t _{HD}	Data input hold		0.00		0.00		0.00	ns
t _{HE}	Enable input hold		0.00		0.00		0.00	ns
t _{CPWHL}	Clock pulse width High to Low	0.39		0.39		0.39		ns
t _{CPWLH}	Clock pulse width Low to High	0.39		0.39		0.39		ns
t _{WASYN}	Asynchronous pulse width	0.37		0.37		0.37		ns
t _{REASYN}	Asynchronous recovery time		0.18		0.17		0.20	ns
t _{HASYN}	Asynchronous removal time		0.00		0.00		0.00	ns
t _{CLR}	Asynchronous Clear-to-Q		0.33		0.31		0.37	ns
t _{PRESET}	Asynchronous Preset-to-Q		0.33		0.31		0.37	ns

HSTL Class I

High-Speed Transceiver Logic is a general-purpose high-speed 1.5 V bus standard (EIA/JESD8-6). The RTAX-S/SL devices support Class I. This requires a differential amplifier input buffer and a push-pull output buffer.

Table 2-42 • DC Input and Output Levels

VIL		VIH		VOL	VOH	IOL	IOH
Min. V	Max. V	Min. V	Max. V1	Max. V	Min. V	mA	mA
-0.3	VREF - 0.1	VREF + 0.1	3.6	0.4	VCC - 0.4	8	-8

AC Loadings

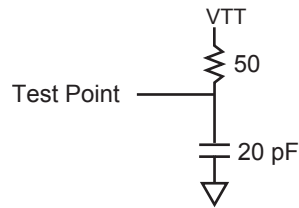

Figure 2-21 • AC Test Loads

Table 2-43 • AC Waveforms, Measuring Points, and Capacitive Loads

Input Low (V)	Input High (V)	Measuring Point* (V)	V _{REF} (typ) (V)	C _{load} (pF)
VREF - 0.5	VREF + 0.5	VREF	0.75	20

Note: *Measuring Point = V_{trip}

Timing Characteristics

Table 2-44 • Worst-Case Military Conditions VCCA = 1.425 V, VCCI = 1.4 V, TJ = 125°C

Parameter	Description	-1 Speed				Std. Speed		Units
		RTAX4000S/SL		RTAX250/1000/2000S/SL		All		
		Min.	Max.	Min.	Max.	Min.	Max.	
1.5 V HSTL Class I I/O Module Timing								
t _{DP}	Input buffer		2.24		2.12		2.49	ns
t _{PY}	Output buffer		5.68		5.35		6.29	ns
t _{CLKQ}	Clock-to-Q for the I/O input register		0.95		0.90		1.05	ns
t _{CLKQ}	Clock-to-Q for the I/O output register and the I/O enable register		0.95		0.90		1.05	ns
t _{SUD}	Data input setup		0.33		0.31		0.36	ns
t _{SUE}	Enable input setup		0.36		0.34		0.40	ns
t _{HD}	Data input hold		0.00		0.00		0.00	ns
t _{HE}	Enable input hold		0.00		0.00		0.00	ns
t _{CPWHL}	Clock pulse width High to Low	0.39		0.39		0.39		ns
t _{CPWLH}	Clock pulse width Low to High	0.39		0.39		0.39		ns
t _{WASYN}	Asynchronous pulse width	0.37		0.37		0.37		ns
t _{REASYN}	Asynchronous recovery time		0.18		0.17		0.20	ns
t _{HASYN}	Asynchronous removal time		0.00		0.00		0.00	ns
t _{CLR}	Asynchronous Clear-to-Q		0.33		0.31		0.37	ns
t _{PRESET}	Asynchronous Preset-to-Q		0.33		0.31		0.37	ns

SSTL2

Stub Series Terminated Logic for 2.5 V is a general-purpose 2.5 V memory bus standard (JESD8-9). The RTAX-S/SL devices support both classes of this standard. This requires a differential amplifier input buffer and a push-pull output buffer.

Class I

Table 2-45 • DC Input and Output Levels

V _{IL}		V _{IH}		VOL	VOH	IOL	IOH
Min. V	Max. V	Min. V	Max. V	Max. V	Min. V	mA	mA
-0.3	VREF - 0.2	VREF + 0.2	3.6	VREF - 0.57	VREF + 0.57	7.6	-7.6

AC Loadings

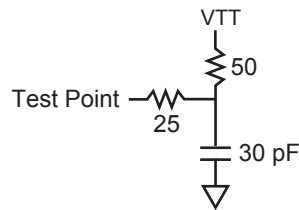

Figure 2-22 • AC Test Loads

Table 2-46 • AC Waveforms, Measuring Points, and Capacitive Loads

Input Low (V)	Input High (V)	Measuring Point* (V)	V _{REF} (typ) (V)	C _{load} (pF)
VREF - 0.75	VREF + 0.75	VREF	1.25	30

Note: *Measuring Point = V_{trip}

Timing Characteristics

Table 2-47 • Worst-Case Military Conditions VCCA = 1.425 V, VCCI = 2.3 V, T_J = 125°C

Parameter	Description	-1 Speed				Std. Speed		Units
		RTAX4000S/SL		RTAX250/1000/2000S/SL		All		
		Min.	Max.	Min.	Max.	Min.	Max.	
2.5 V SSTL2 Class I I/O Module Timing								
t _{DP}	Input buffer		2.28		2.14		2.52	ns
t _{PY}	Output buffer		2.77		2.61		3.07	ns
t _{CLKQ}	Clock-to-Q for the I/O input register		0.95		0.90		1.05	ns
t _{CLKQ}	Clock-to-Q for the I/O output register and the I/O enable register		0.95		0.90		1.05	ns
t _{SUD}	Data input setup		0.33		0.31		0.36	ns
t _{SUE}	Enable input setup		0.36		0.34		0.40	ns
t _{HD}	Data input hold		0.00		0.00		0.00	ns
t _{HE}	Enable input hold		0.00		0.00		0.00	ns
t _{CPWHL}	Clock pulse width High to Low	0.39		0.39		0.39		ns
t _{CPWLH}	Clock pulse width Low to High	0.39		0.39		0.39		ns
t _{WASYN}	Asynchronous pulse width	0.37		0.37		0.37		ns
t _{REASYN}	Asynchronous recovery time		0.18		0.17		0.20	ns
t _{HASYN}	Asynchronous removal time		0.00		0.00		0.00	ns
t _{CLR}	Asynchronous Clear-to-Q		0.33		0.31		0.37	ns
t _{PRESET}	Asynchronous Preset-to-Q		0.33		0.31		0.37	ns

Class II

Table 2-48 • DC Input and Output Levels

VIL		VIH		VOL	VOH	IOL	IOH
Min. V	Max. V	Min. V	Max. V	Max. V	Min. V	mA	mA
-0.3	VREF - 0.2	VREF + 0.2	3.6	VREF - 0.8	VREF + 0.8	15.2	-15.2

AC Loadings

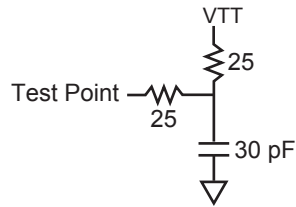
Figure 2-23 • AC Test Loads
Table 2-49 • AC Waveforms, Measuring Points, and Capacitive Loads

Input Low (V)	Input High (V)	Measuring Point* (V)	VREF (typ) (V)	C _{load} (pF)
VREF - 0.75	VREF+0.75	VREF	1.25	30

Note: *Measuring Point = V_{trip}

Timing Characteristics

Table 2-50 • Worst-Case Military Conditions VCCA = 1.425 V, VCCI = 2.3 V, T_J = 125°C

Parameter	Description	-1 Speed				Std. Speed		Units
		RTAX4000S/SL		RTAX250/1000/2000S/SL		All		
		Min.	Max.	Min.	Max.	Min.	Max.	
2.5 V SSTL2 Class II I/O Module Timing								
t _{DP}	Input buffer		2.36		2.22		2.61	ns
t _{PY}	Output buffer		2.77		2.61		3.07	ns
t _{iCLKQ}	Clock-to-Q for the I/O input register		0.95		0.90		1.05	ns
t _{oCLKQ}	Clock-to-Q for the I/O output register and the I/O enable register		0.95		0.90		1.05	ns
t _{SUD}	Data input setup		0.33		0.31		0.36	ns
t _{SUE}	Enable input setup		0.36		0.34		0.40	ns
t _{HD}	Data input hold		0.00		0.00		0.00	ns
t _{HE}	Enable input hold		0.00		0.00		0.00	ns
t _{CPWHL}	Clock pulse width High to Low	0.39		0.39		0.39		ns
t _{CPWLH}	Clock pulse width Low to High	0.39		0.39		0.39		ns
t _{WASYN}	Asynchronous pulse width	0.37		0.37		0.37		ns
t _{REASYN}	Asynchronous recovery time		0.18		0.17		0.20	ns
t _{HASYN}	Asynchronous removal time		0.00		0.00		0.00	ns
t _{CLR}	Asynchronous Clear-to-Q		0.33		0.31		0.37	ns
t _{PRESET}	Asynchronous Preset-to-Q		0.33		0.31		0.37	ns

SSTL3

Stub Series Terminated Logic for 3.3 V is a general-purpose 3.3 V memory bus standard (JESD8-8). The RTAX-S/SL devices support both classes of this standard. This requires a differential amplifier input buffer and a push-pull output buffer.

Class I

Table 2-51 • DC Input and Output Levels

VIL		VIH		VOL	VOH	IOL	IOH
Min. V	Max. V	Min. V	Max. V	Max. V	Min. V	mA	mA
-0.3	VREF - 0.2	VREF + 0.2	3.6	VREF - 0.6	VREF + 0.6	8	-8

AC Loadings

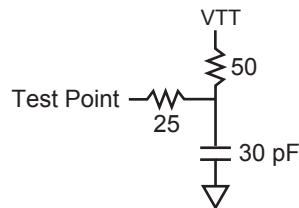

Figure 2-24 • AC Test Loads

Table 2-52 • AC Waveforms, Measuring Points, and Capacitive Loads

Input Low (V)	Input High (V)	Measuring Point* (V)	VREF (typ) (V)	C _{load} (pF)
VREF-1.0	VREF+1.0	VREF	1.50	30

Note: *Measuring Point = V_{trip}

Timing Characteristics

Table 2-53 • Worst-Case Military Conditions VCCA = 1.425 V, VCCI = 3.0 V, T_J = 125°C

Parameter	Description	-1 Speed				Std. Speed		Units
		RTAX4000S/SL		RTAX250/1000/2000S/SL		All		
		Min.	Max.	Min.	Max.	Min.	Max.	
3.3 V SSTL3 Class I I/O Module Timing								
t _{DP}	Input buffer		2.22		2.09		2.46	ns
t _{PY}	Output buffer		2.70		2.55		2.99	ns
t _{iCLKQ}	Clock-to-Q for the I/O input register		0.95		0.90		1.05	ns
t _{oCLKQ}	Clock-to-Q for the I/O output register and the I/O enable register		0.95		0.90		1.05	ns
t _{SUD}	Data input setup		0.33		0.31		0.36	ns
t _{SUE}	Enable input setup		0.36		0.34		0.40	ns
t _{HD}	Data input hold		0.00		0.00		0.00	ns
t _{HE}	Enable input hold		0.00		0.00		0.00	ns
t _{CPWHL}	Clock pulse width High to Low	0.39		0.39		0.39		ns
t _{CPWLH}	Clock pulse width Low to High	0.39		0.39		0.39		ns
t _{WASYN}	Asynchronous pulse width	0.37		0.37		0.37		ns
t _{REASYN}	Asynchronous recovery time		0.18		0.17		0.20	ns
t _{HASYN}	Asynchronous removal time		0.00		0.00		0.00	ns
t _{CLR}	Asynchronous Clear-to-Q		0.33		0.31		0.37	ns
t _{PRESET}	Asynchronous Preset-to-Q		0.33		0.31		0.37	ns

Class II

Table 2-54 • DC Input and Output Levels

VIL		VIH		VOL	VOH	IOL	IOH
Min. V	Max. V	Min. V	Max. V	Max. V	Min. V	mA	mA
-0.3	VREF - 0.2	VREF + 0.2	3.6	VREF - 0.8	VREF + 0.8	16	-16

AC Loadings

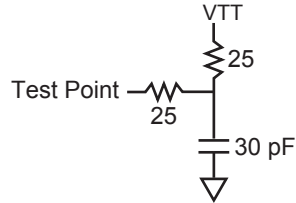
Figure 2-25 • AC Test Loads
Table 2-55 • AC Waveforms, Measuring Points, and Capacitive Loads

Input Low (V)	Input High (V)	Measuring Point* (V)	V _{REF} (typ) (V)	C _{load} (pF)
VREF - 1.0	VREF + 1.0	VREF	1.50	30

Note: *Measuring Point = V_{trip}

Timing Characteristics

Table 2-56 • Worst-Case Military Conditions VCCA = 1.425 V, VCCI = 3.0 V, T_J = 125°C

Parameter	Description	-1 Speed				Std. Speed		Units
		RTAX4000S/SL		RTAX250/1000/2000S/SL		All		
		Min.	Max.	Min.	Max.	Min.	Max.	
3.3 V SSTL3 Class II I/O Module Timing								
t _{DP}	Input buffer		2.30		2.16		2.55	ns
t _{PY}	Output buffer		2.70		2.55		2.99	ns
t _{CLKQ}	Clock-to-Q for the I/O input register		0.95		0.90		1.05	ns
t _{CLKQ}	Clock-to-Q for the I/O output register and the I/O enable register		0.95		0.90		1.05	ns
t _{SUD}	Data input setup		0.33		0.31		0.36	ns
t _{SUE}	Enable input setup		0.36		0.34		0.40	ns
t _{HD}	Data input hold		0.00		0.00		0.00	ns
t _{HE}	Enable input hold		0.00		0.00		0.00	ns
t _{CPWHL}	Clock pulse width High to Low	0.39		0.39		0.39		ns
t _{CPWLH}	Clock pulse width Low to High	0.39		0.39		0.39		ns
t _{WASYN}	Asynchronous pulse width	0.37		0.37		0.37		ns
t _{REASYN}	Asynchronous recovery time		0.18		0.17		0.20	ns
t _{HASYN}	Asynchronous removal time		0.00		0.00		0.00	ns
t _{CLR}	Asynchronous Clear-to-Q		0.33		0.31		0.37	ns
t _{PRESET}	Asynchronous Preset-to-Q		0.33		0.31		0.37	ns

Differential Standards

Physical Implementation

Implementing differential I/O standards requires the configuration of a pair of external I/O pads, resulting in a single internal signal. To facilitate construction of the differential pair, a single I/O cluster contains the resources for a pair of I/Os. Configuration of the I/O Cluster as a differential pair is handled by Microsemi's Designer software when the user instantiates a differential I/O macro in the design.

Differential I/Os can also be used in conjunction with the embedded Input Register (InReg), Output Register (OutReg), and Enable Register (EnReg). However, there is no support for bidirectional I/Os or tristates with these standards.

LVDS

Low-Voltage Differential Signal (ANSI/TIA/EIA-644) is a high-speed differential I/O standard. It requires that one data bit is carried through two signal lines, so two pins are needed. It also requires an external resistor termination. The voltage swing between these two signal lines is approximately 350 mV.

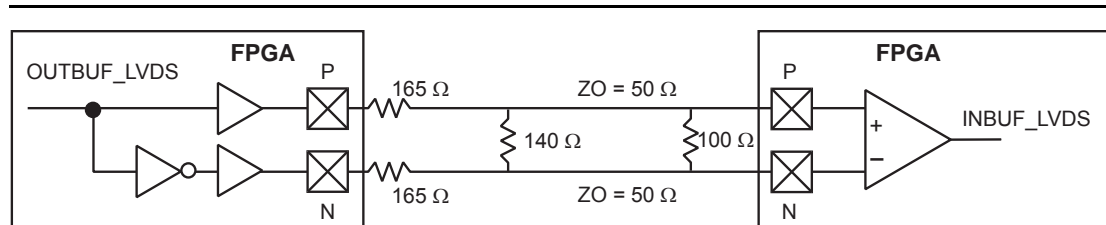

Figure 2-26 • LVDS Circuit

The LVDS circuit consists of a differential driver connected to a terminated receiver through a constant-impedance transmission line. The receiver is a wide-common-mode-range differential amplifier. The common-mode range is from 0.2 V to 2.2 V for a differential input with 400 mV swing.

To implement the driver for the LVDS circuit, drivers from two adjacent I/O cells are used to generate the differential signals (Note that the driver is not a current-mode driver). This driver provides a nominal constant current of 3.5 mA. When this current flows through a 100 Ω termination resistor on the receiver side, a voltage swing of 350 mV is developed across the resistor. The direction of the current flow is controlled by the data fed to the driver.

An external-resistor network (three resistors) is needed to reduce the voltage swing to about 350 mV. Therefore, four external resistors are required, three for the driver and one for the receiver.

Table 2-57 • DC Input and Output Levels

DC Parameter	Description	Min.	Typ.	Max.	Units
VCCI ¹	Supply voltage	2.375	2.5	2.625	V
VOL	Output low voltage	0.9	1.075	1.25	V
VOH	Output high voltage	1.25	1.425	1.6	V
VI	Input voltage	0		2.925	V
VODIFF	Differential output voltage	250	350	450	mV
VOCM	Output common mode voltage	1.125	1.25	1.375	V
VICM ²	Input common mode voltage	0.2	1.25	2.2	V
VIDIFF	Differential input voltage	100	350		mV

Notes:

1. $\pm 5\%$
2. Differential input voltage = ± 400 mV.

AC Loadings

For AC test loads, see the above LVDS circuit.

Table 2-58 • AC Waveforms, Measuring Points, and Capacitive Loads

Input Low (V)	Input High (V)	Measuring Point* (V)	C _{load} (pF)
1.2 – 0.125	1.2 + 0.125	1.2	N/A

Note: *Measuring Point = V_{trip}

Timing Characteristics

Table 2-59 • Worst-Case Military Conditions VCCA = 1.425 V, VCCI = 2.3 V, T_J = 125°C

Parameter	Description	–1 Speed				Std. Speed		Units
		RTAX4000S/SL		RTAX250/1000/2000S/SL		All		
		Min.	Max.	Min.	Max.	Min.	Max.	
LVDS I/O Module Timing								
t _{DP}	Input buffer		2.12		2.00		2.35	ns
t _{PY}	Output buffer		2.70		2.54		2.99	ns
t _{CLKQ}	Clock-to-Q for the I/O input register		0.95		0.90		1.05	ns
t _{CLKQ}	Clock-to-Q for the I/O output register and the I/O enable register		0.95		0.90		1.05	ns
t _{SUD}	Data input setup		0.33		0.31		0.36	ns
t _{SUE}	Enable input setup		0.36		0.34		0.40	ns
t _{HD}	Data input hold		0.00		0.00		0.00	ns
t _{HE}	Enable input hold		0.00		0.00		0.00	ns
t _{CPWHL}	Clock pulse width High to Low	0.39		0.39		0.39		ns
t _{CPWLH}	Clock pulse width Low to High	0.39		0.39		0.39		ns
t _{WASYN}	Asynchronous pulse width	0.37		0.37		0.37		ns
t _{REASYN}	Asynchronous recovery time		0.18		0.17		0.20	ns
t _{HASYN}	Asynchronous removal time		0.00		0.00		0.00	ns
t _{CLR}	Asynchronous Clear-to-Q		0.33		0.31		0.37	ns
t _{PRESET}	Asynchronous Preset-to-Q		0.33		0.31		0.37	ns

LVPECL

Low-Voltage Positive Emitter-Coupled Logic (LVPECL) is another differential I/O standard. It requires that one data bit is carried through two signal lines. Like LVDS, two pins are needed. It also requires external resistor termination. The voltage swing between these two signal lines is approximately 850 mV.

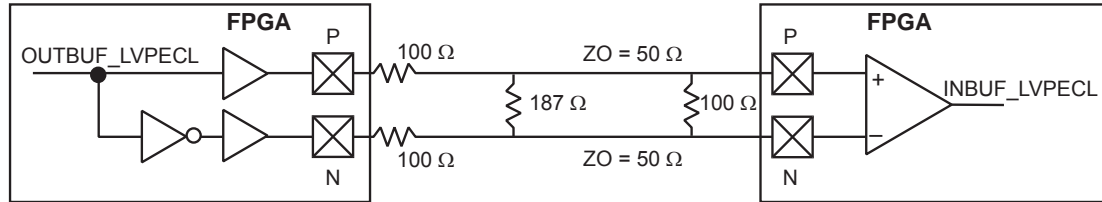

Figure 2-27 • LVPECL Circuit

The LVPECL circuit is similar to the LVDS scheme. It requires four external resistors, three for the driver and one for the receiver. The values for the three driver resistors are different from that of LVDS, since the output voltage levels are different. Please note that the V_{OH} levels are 200 mV below the standard LVPECL levels.

Table 2-60 • DC Input and Output Levels

DC Parameter	Description	Min.	Max.	Min.	Max.	Min.	Max.	Units
VCCI	Supply voltage	3.0		3.3		3.6		V
VOL	Output Low voltage	0.96	1.27	1.06	1.43	1.30	1.57	V
VOH	Output High voltage	1.8	2.11	1.92	2.28	2.13	2.41	V
VIL	Input Low voltages	0.86	2.125	0.86	2.125	0.86	2.125	V
VIH	Input High voltages	1.49	2.72	1.49	2.72	1.49	2.72	V
VODIFF	Differential output voltage	0.625	0.97	0.625	0.97	0.625	0.97	V
VOCM	Output common mode voltage	1.762	1.98	1.762	1.98	1.762	1.98	V
VICM	Input common mode voltage	1.01	2.57	1.01	2.57	1.01	2.57	
VIDIFF	Input differential voltage	300	–	300	–	300	–	mV

AC Loadings

For AC test loads, See the above LVPECL circuit.

Table 2-61 • AC Waveforms, Measuring Points, and Capacitive Loads

Input Low (V)	Input High (V)	Measuring Point* (V)	C_{load} (pF)
1.6 – 0.3	1.6 + 0.3	1.6	N/A

Note: *Measuring Point = V_{trip}

Timing Characteristics

Table 2-62 • Worst-Case Military Conditions VCCA = 1.425 V, VCCI = 3.0 V, T_J = 125°C

Parameter	Description	-1 Speed				Std. Speed		Units
		RTAX4000S/SL		RTAX250/1000/2000S/SL		All		
		Min.	Max.	Min.	Max.	Min.	Max.	
LVPECL Output Module Timing								
t _{DP}	Input buffer		1.94		1.83		2.15	ns
t _{PY}	Output buffer		2.60		2.45		2.88	ns
t _{CLKQ}	Clock-to-Q for the I/O input register		0.95		0.90		1.05	ns
t _{CLKQ}	Clock-to-Q for the I/O output register and the I/O enable register		0.95		0.90		1.05	ns
t _{SUD}	Data input setup		0.33		0.31		0.36	ns
t _{SUE}	Enable input setup		0.36		0.34		0.40	ns
t _{HD}	Data input hold		0.00		0.00		0.00	ns
t _{HE}	Enable input hold		0.00		0.00		0.00	ns
t _{CPWHL}	Clock pulse width High to Low	0.39		0.39		0.39		ns
t _{CPWLH}	Clock pulse width Low to High	0.39		0.39		0.39		ns
t _{WASYN}	Asynchronous pulse width	0.37		0.37		0.37		ns
t _{REASYN}	Asynchronous recovery time		0.18		0.17		0.20	ns
t _{HASYN}	Asynchronous removal time		0.00		0.00		0.00	ns
t _{CLR}	Asynchronous Clear-to-Q		0.33		0.31		0.37	ns
t _{PRESET}	Asynchronous Preset-to-Q		0.33		0.31		0.37	ns

Module Specifications

C-Cell

Introduction

The C-cell is one of the two logic module types in the RTAX-S/SL/DSP architecture. It is the combinatorial logic resource in the RTAX-S/SL/DSP device. The RTAX-S/SL/DSP architecture implements a new Combinatorial Cell that is an extension of the C-cell implemented in the A54SX-A family. The main enhancement of the new C-cell is the addition of carry-chain logic.

The C-cell can be used in a carry-chain mode to construct arithmetic functions. If carry-chain logic is not required, it can be disabled.

The C-cell features the following (Figure 2-28):

- Eight-input MUX (data: D0-D3, select: A0, A1, B0, B1). User signals can be routed to any one of these inputs. Any of the C-cell inputs (D0-D3, A0, A1, B0, B1) can be tied to one of the four routed clocks (CLKE/F/G/H).
- Inverter (DB input) can be used to drive a complement signal of any of the inputs to the C-cell.
- A carry input and a carry output. The carry input signal of the C-cell is the carry output from the C-cell directly to the north.
- Carry connect for carry-chain logic with a signal propagation time of less than 0.1 ns.
- A hardwired connection (direct connect) to the adjacent R-cell (Register Cell) for all C-cells on the east side of a SuperCluster with a signal propagation time of less than 0.1 ns.

This layout of the C-cell (and the C-cell Cluster) enables the implementation of over 4,000 functions of up to five bits. For example, two C-cells can be used together to implement a four-input XOR function in a single cell delay.

The carry-chain configuration is handled automatically for the user with the extensive Microsemi macro library. Refer to the *Antifuse Macro Library Guide* for a complete listing of available RTAX-S/SL macros.

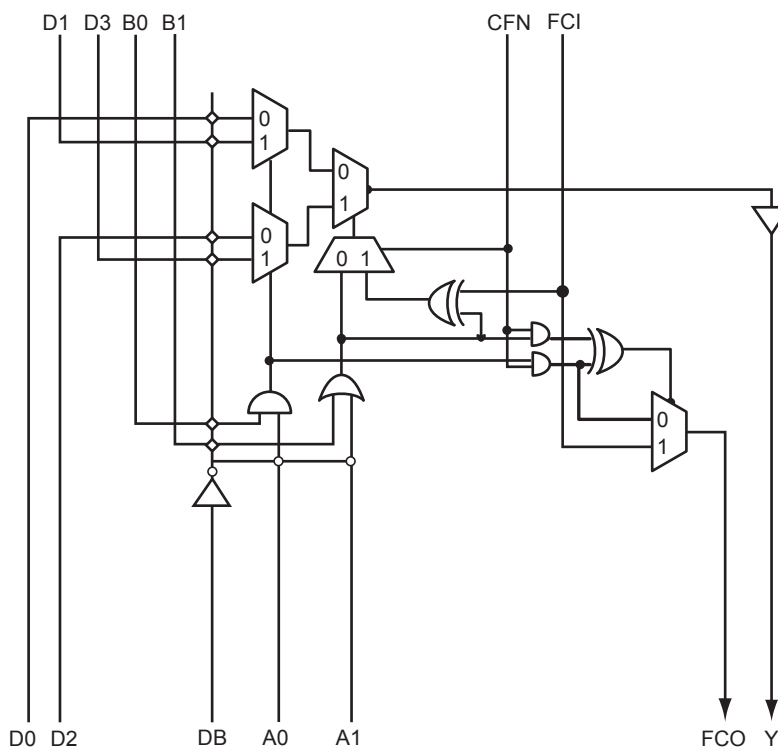

Figure 2-28 • C-Cell

Timing Model and Waveforms

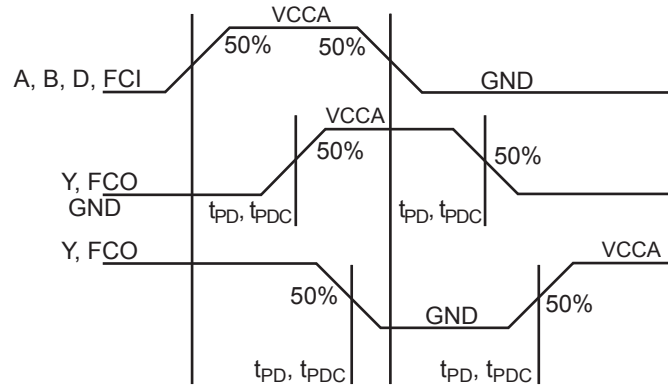

Figure 2-29 • C-Cell Timing Model and Waveforms

Timing Characteristics

Table 2-63 • Worst-Case Military Conditions $V_{CCA} = 1.425\text{ V}$, $V_{CCI} = 3.0\text{ V}$, $T_J = 125^\circ\text{C}$

Parameter	Description	-1 Speed				Std. Speed		Units
		RTAX4000S/SL		RTAX250/1000/2000S/SL		All		
		Min.	Max.	Min.	Max.	Min.	Max.	
C-Cell Propagation Delays								
t_{PD}	Any input to output		0.99		0.93		1.10	ns
t_{PDC}	Any input to carry chain output (FCO)		0.73		0.69		0.81	ns
t_{PDB}	Any input thorough DB when 1 input is used		1.55		1.46		1.72	ns
t_{CCY}	Input carry chain (FCI) to Y		0.80		0.75		0.88	ns
t_{CC}	Input carry chain (FCI) to carry chain output (FCO)		0.11		0.10		0.12	ns

Carry-Chain Logic

The RTAX-S/SL/DSP dedicated carry-chain logic offers a very compact solution for implementing arithmetic functions without sacrificing performance.

To implement the carry-chain logic, two C-cells in a Cluster are connected together so the FCO (i.e., carry out) for the two bits is generated in a Carry Look-ahead scheme to achieve minimum propagation delay from the FCI (i.e., carry in) into the two-bit Cluster. The two-bit carry logic is shown in [Figure 2-30](#).

The FCI of one C-cell pair is driven by the FCO of the C-cell pair immediately above it. Similarly, the FCO of one C-cell pair, drives the FCI input of the C-cell pair immediately below it ([Figure 1-5 on page 1-3](#) and [Figure 2-31 on page 2-86](#)).

The carry-chain logic is selected via the CFN input. When carry logic is not required, this signal is deasserted to save power. Again, this configuration is handled automatically for the user through the Microsemi macro library.

The signal propagation delay between two C-cells in the carry-chain sequence is 0.1 ns.

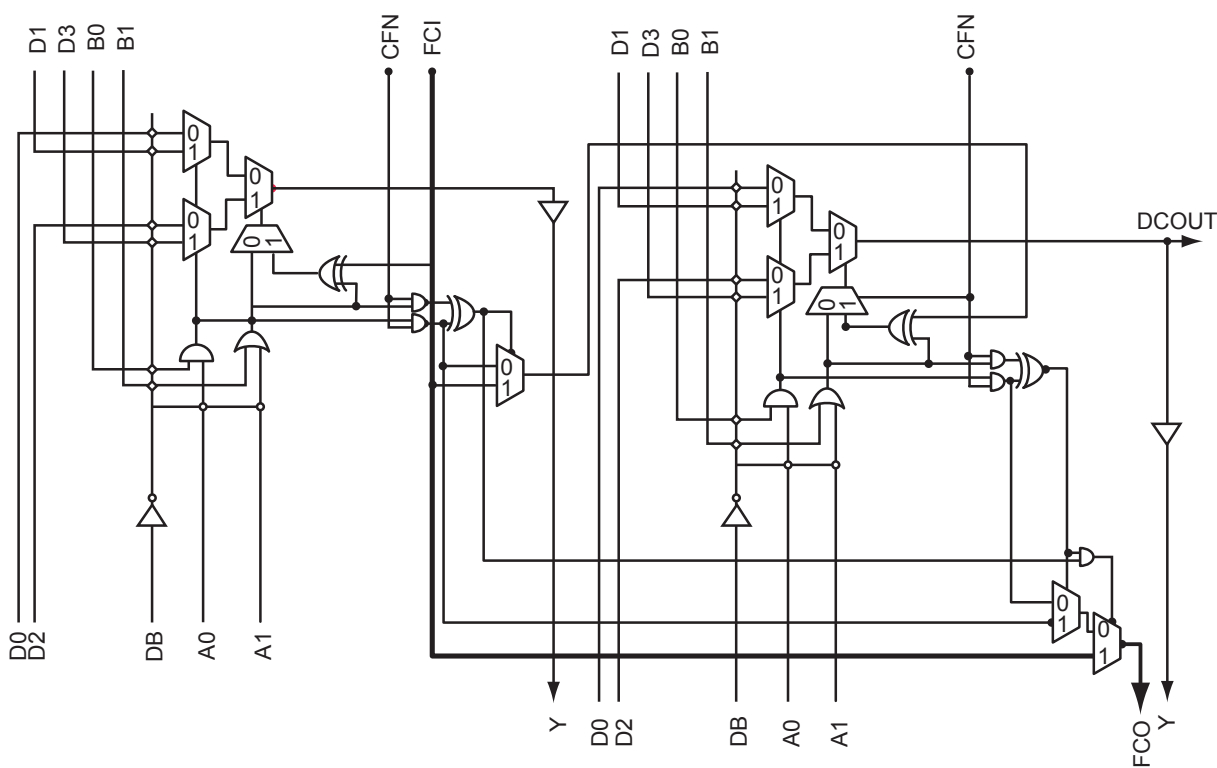
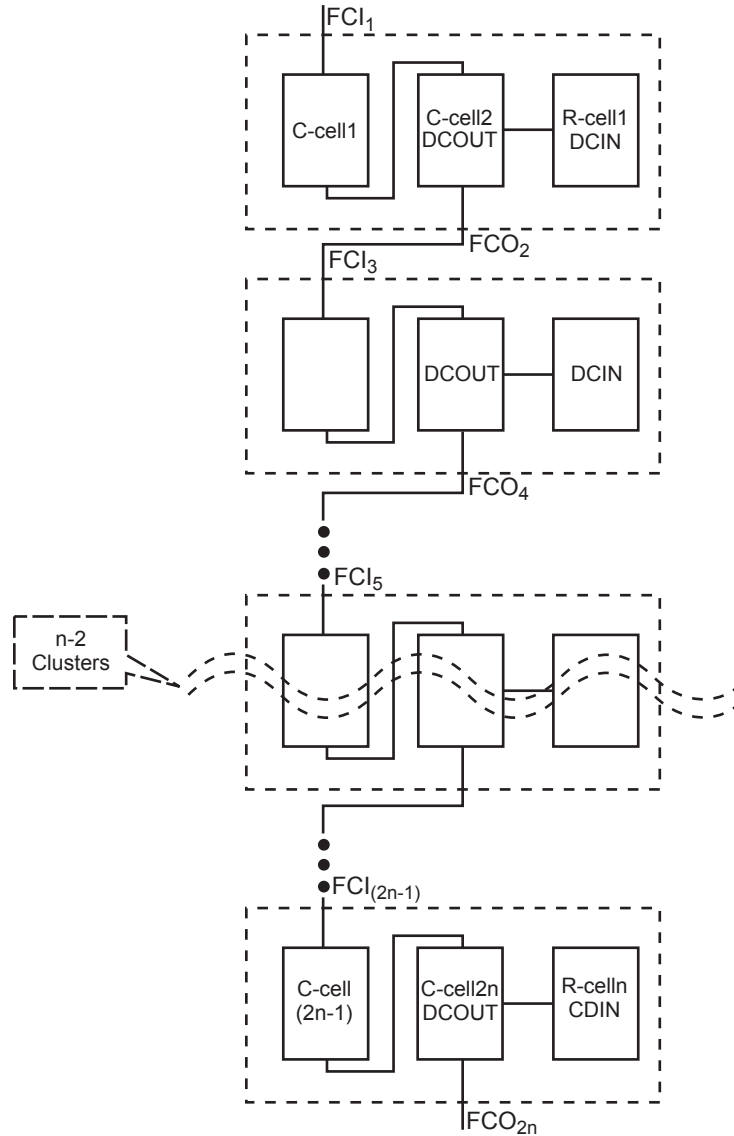

Figure 2-30 • RTAX-S/SL/DSP Two-Bit Carry Logic



Note: The carry-chain sequence can end on either C-cell.

Figure 2-31 • Carry-Chain Sequencing of C-Cells

Timing Characteristics

Refer to the C-cell timing characteristics in [Table 2-63](#) on [page 2-84](#) for more information on carry-chain timing.

R-Cell

Introduction

The R-cell, the sequential logic resource of the RTAX-S/SL/DSP devices, is the second logic module type in the RTAX-S/SL/DSP family architecture. The RTAX-S/SL/DSP R-cell is an enhanced version of the A54SX-A R-cell. It includes additional clock inputs for all eight global resources of the RTAX-S/SL/DSP architecture as well as global presets and clears ([Figure 2-32](#)).

The main features of the R-cell include the following:

- Direct connection to the adjacent logic module through the hardwired connection DCIN. DCIN is driven by the DCOUT of an adjacent C-cell via the Direct-Connect routing resource, providing a connection with less than 0.1 ns of routing delay.
- The R-cell can be used as a standalone flip-flop. It can be driven by any C-cell or I/O modules through the regular routing structure (using DIN as a routable data input). This gives the option of using the R-cell as a 2:1 MUXed flip-flop as well.
- Provision of data enable-input (S0).
- Independent active low asynchronous clear (CLR).
- Independent active low asynchronous preset (PSET). If both CLR and PSET are low, CLR has higher priority.
- Clock can be driven by any of the following (CKP selects clock polarity):
 - One of the four high performance hardwired fast clocks (HCLKs)
 - One of the four routed clocks (CLKs)
 - User signals
- Global power-on clear (GCLR) and preset (GPSET), which drive each flip-flop on a chip-wide basis.
 - When the Global Set Fuse option in the Designer software is unchecked (by default), GCLR = 0 and GPSET = 1 at device power-up. When the option is checked, GCLR = 1 and GPSET = 0. Both pins are pulled HIGH when the device is in user mode.
- S0, S1, PSET, and CLR can be driven by routed clocks CLKE/F/G/H or user signals.
- DIN and S1 can be driven by user signals.

As with the C-cell, the configuration of the R-cell to perform various functions is handled automatically for the user through Microsemi's extensive macro library (please see the [Macro Library Guide](#) for a complete listing of available RTAX-S/SL macros).

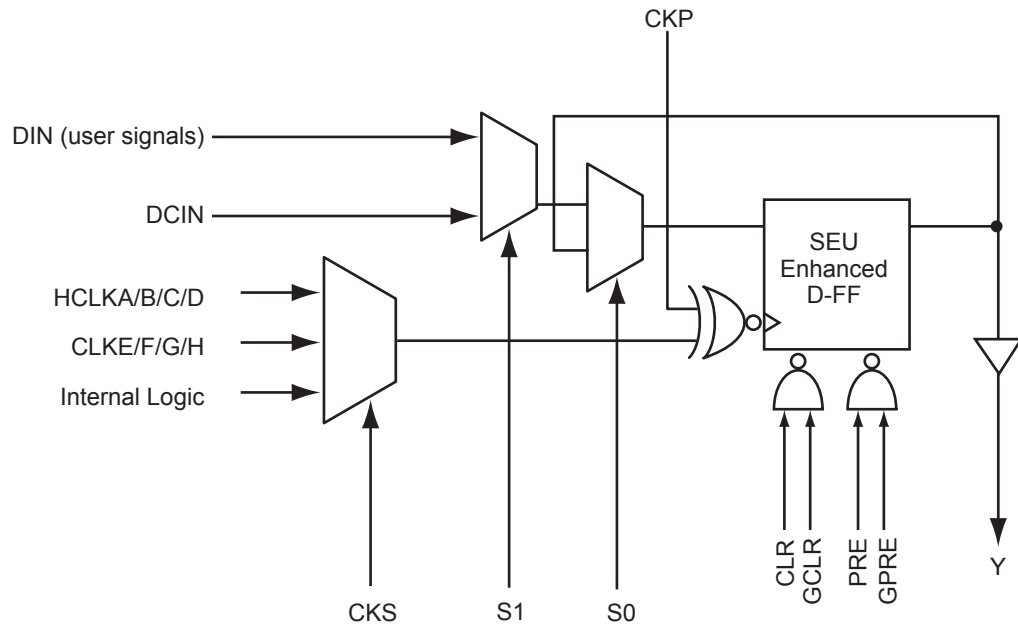

Figure 2-32 • R-Cell

SEU Hardened D Flip-Flop (DFF)

In order to meet the stringent SEU requirements of a LET_{TH} greater than $37 \text{ MeV-cm}^2/\text{mg}$, the internal design of the R-cell was modified without changing the functionality of the cell. [Figure 2-33](#) illustrates a simplified representation of how the D flip-flop in the SuperCluster is implemented in the RTAX-S/SL/DSP architecture. The flip-flop consists of a master and a slave latch gated by opposite edges of the clock. Each latch is constructed by feeding back the output to the input stage. The potential problem in a space environment is that either of the latches can change state when hit by a particle with enough energy.

To achieve the SEU requirements, the D flip-flop in the RTAX-S/SL/DSP R-cell is enhanced ([Figure 2-34](#)). Both the master and slave "latches" are actually implemented with three latches. The asynchronous self-correcting feedback paths of each of the three latches is voted with the outputs of the other two latches. If one of the three latches is struck by an ion and starts to change state, the voting with the other two latches prevents the change from feeding back and permanently latching. Care was taken in the layout to ensure that a single ion strike could not affect more than one latch. [Figure 2-35 on page 2-90](#) is a simplified schematic of the test circuitry that has been added to test the functionality of all the components of the flip-flop. The inputs to each of the three latches are independently controllable, so the voting circuitry in the asynchronous self-correcting feedback paths can be tested exhaustively. This testing is performed on an unprogrammed array during wafer sort, final test, and post-burn-in test. This test circuitry cannot be used to test the flip-flops once the device has been programmed.

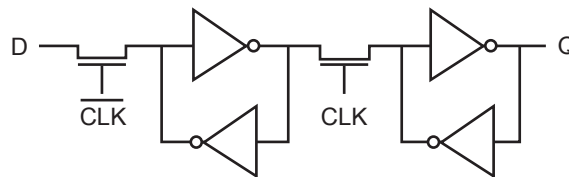

Figure 2-33 • RTAX-S/SL/DSP R-cell Implementation of D Flip-Flop

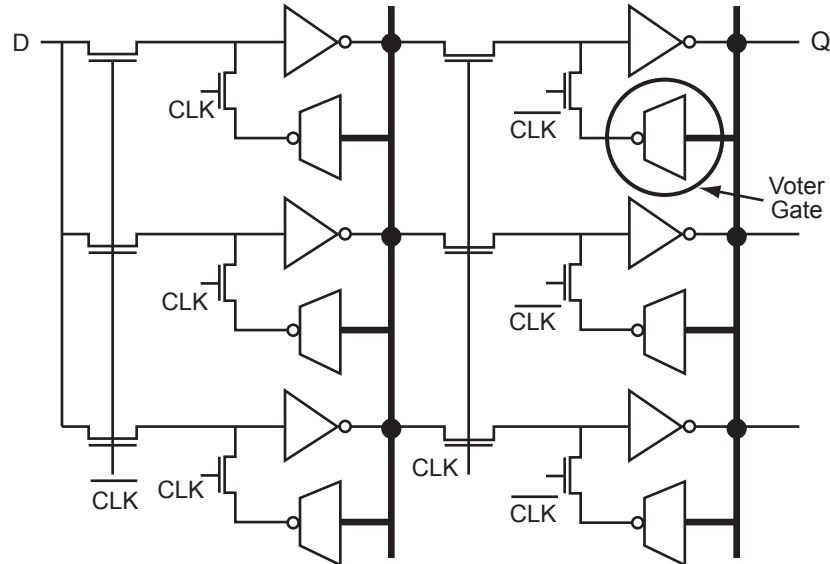

Figure 2-34 • RTAX-S/SL/DSP R-cell Implementation of D Flip-Flop Using Voter Gate Logic

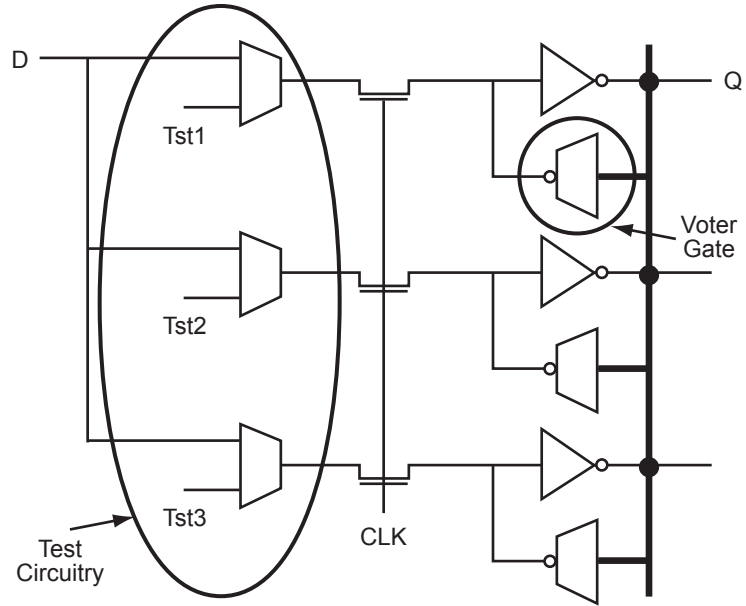

Figure 2-35 • RTAX-S/SL/DSP R-Cell Implementation – Test Circuitry

Timing Models and Waveforms

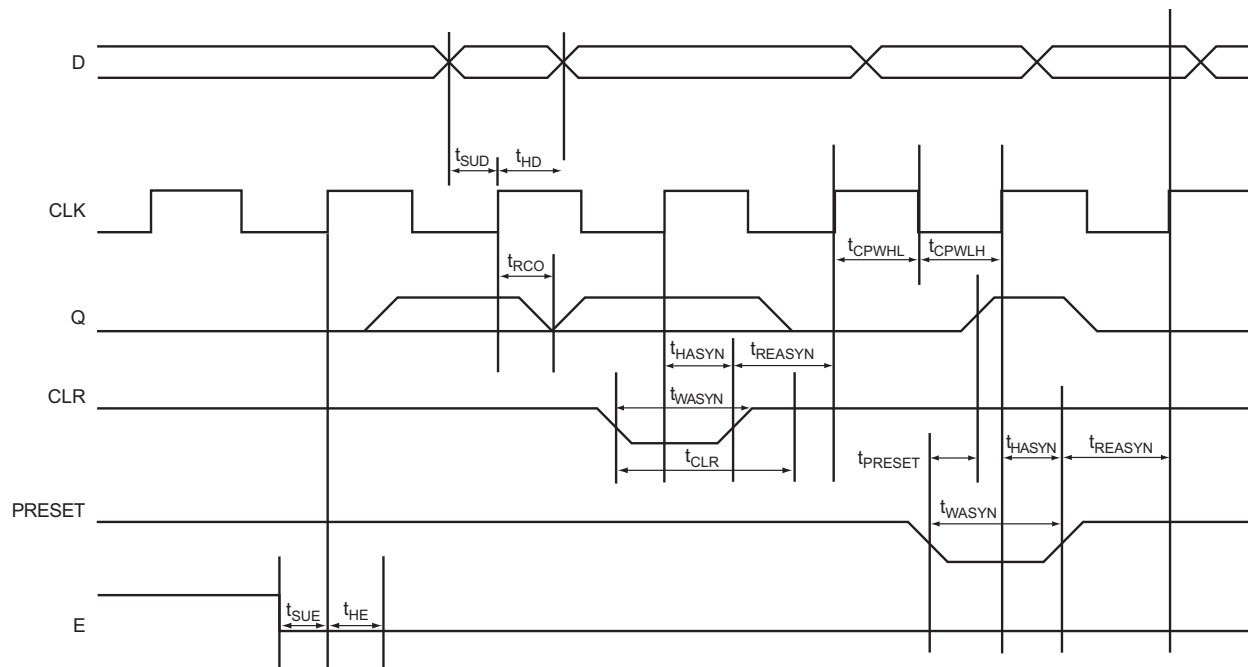

Figure 2-36 • R-Cell Delays

Timing Characteristics

Table 2-64 • Worst-Case Military Conditions $V_{CCA} = 1.425\text{ V}$, $V_{CCI} = 3.0\text{ V}$, $T_J = 125^\circ\text{C}$

Parameter	Description	-1 Speed				Std. Speed		Units
		RTAX4000S/SL		RTAX250/1000/2000S/SL		All		
		Min.	Max.	Min.	Max.	Min.	Max.	
R-Cell Propagation Delays								
t_{RCO}	Sequential Clock to Q		1.00		0.94		1.10	ns
t_{CLR}	Asynchronous Clear to Q		0.66		0.62		0.73	ns
t_{PRESET}	Asynchronous Preset to Q		0.79		0.75		0.88	ns
t_{SUD}	FF Data input setup	0.22		0.21		0.25		ns
t_{SUE}	FF Enable input setup	0.22		0.21		0.25		ns
t_{HD}	FF Data Hold	0.00		0.00		0.00		ns
t_{HE}	FF Enable Hold time	0.00		0.00		0.00		ns
t_{WASYN}	Asynchronous Pulse width	0.48		0.48		0.48		ns
t_{REASYN}	Asynchronous Recovery time	0.00		0.00		0.00		ns
t_{HASYN}	Asynchronous Removal time	0.00		0.00		0.00		ns
t_{CPWHL}	Clock pulse width high to low	0.35		0.35		0.35		ns
t_{CPWLH}	Clock pulse width low to high	0.36		0.36		0.36		ns

Buffer Module

Introduction

An additional resource inside each SuperCluster is the Buffer (B) module (Figure 1-4 on page 1-3).

When a fanout constraint is applied to a design, the synthesis tool inserts buffers as needed. The buffer module has been added to the RTAX-S/SL/DSP architecture to avoid logic duplication resulting from the hard fanout constraints. The router utilizes this logic resource to save area and reduce loading and delays on medium-to-high-fanout nets.

Timing Models and Waveforms

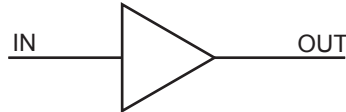

Figure 2-37 • Buffer Module Timing Model

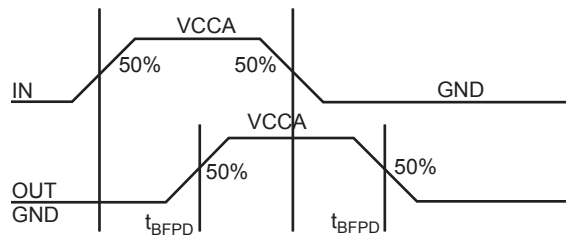

Figure 2-38 • Buffer Module Waveform

Timing Characteristics

Table 2-65 • Worst-Case Military Conditions $V_{CCA} = 1.425\text{ V}$, $V_{CCI} = 3.0\text{ V}$, $T_J = 125^\circ\text{C}$

Parameter	Description	-1 Speed				Std. Speed		Units
		RTAX4000S/SL		RTAX250/1000/2000S/SL		All		
		Min.	Max.	Min.	Max.	Min.	Max.	
t_{BFPD}	Any input to output Y		0.18		0.17		0.20	ns

Mathblock Timing Specification

Mathblock Timing Characteristics

Table 2-66 • Mathblock with All Registers Used
 Worst-Case Military Conditions $V_{CCA} = 1.425\text{ V}$, $T_J = 125^\circ\text{C}$

Parameter	Description	Std. Speed		Units
		Min.	Max.	
t_{MSUR}	A, B, control register setup vs. CLK	0.36		ns
t_{MHR}	A, B, control register hold vs. CLK	0.00		ns
t_{MSUC}	Carry inputs setup vs. CLK	4.40		ns
t_{MHC}	Carry inputs hold vs. CLK	0.00		ns
t_{MCQR}	Sequential clock to output propagation delay		3.83	ns
t_{MPMIN}	CLK Minimum period	8.05		ns

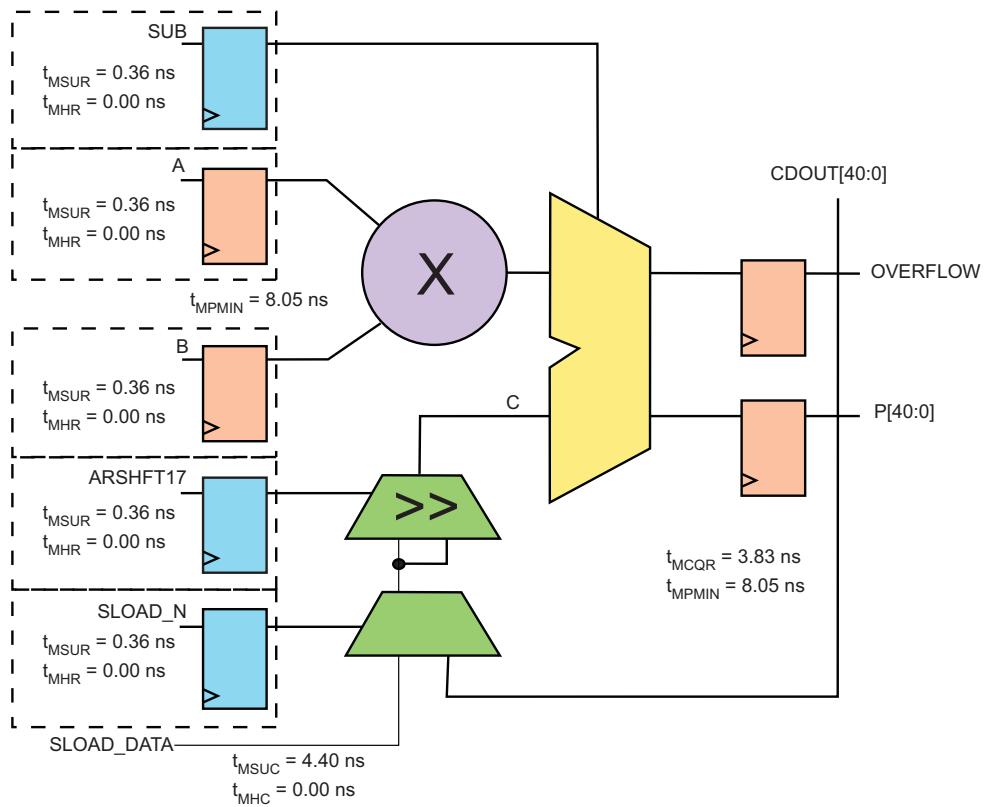

Figure 2-39 • Timing Diagram for Mathblock with All Registers Used

Table 2-67 • Mathblock with Output Registers Used and Input Registers Bypassed
Worst-Case Military Conditions $V_{CCA} = 1.425\text{ V}$, $T_J = 125^\circ\text{C}$

Parameter	Description	Std. Speed		Units
		Min.	Max.	
t_{MSUO}	Output register setup vs. CLK ¹	5.77		ns
t_{MHO}	Output register hold vs. CLK ²	0.00		ns
t_{MSUC}	Carry inputs setup vs. CLK	4.40		ns
t_{MHC}	Carry inputs hold vs. CLK	0.00		ns
t_{MCQO}	Sequential clock to output propagation delay		3.83	ns
t_{MPMIN}	CLK Minimum period	8.05		ns

Notes:

1. This parameter originally was named "A, B, control register setup vs. CLK."
2. This parameter originally was named "A, B, control register hold vs. CLK."

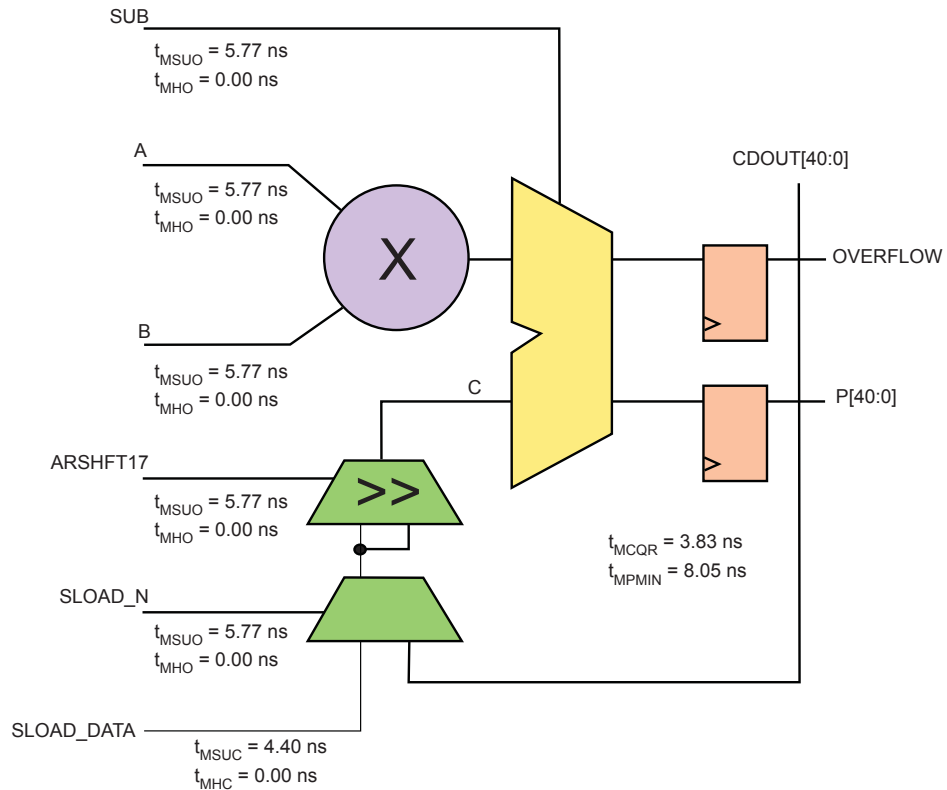

Figure 2-40 • Timing Diagram for Mathblock with Output Registers Used and Input Register Bypassed

**Table 2-68 • Mathblock with Output Registers Bypassed and Input Registers Used
Worst-Case Military Conditions VCCA = 1.425 V, T_J = 125°C**

Parameter	Description	Std. Speed		Units
		Min.	Max.	
t _{MSUR}	A, B, control register setup vs. CLK	0.36		ns
t _{MHR}	A, B, control register hold vs. CLK	0.00		ns
t _{MCQI}	Sequential clock to output propagation delay		7.97	ns
t _{MPDC}	Carry inputs to any outputs propagation delay		7.43	ns

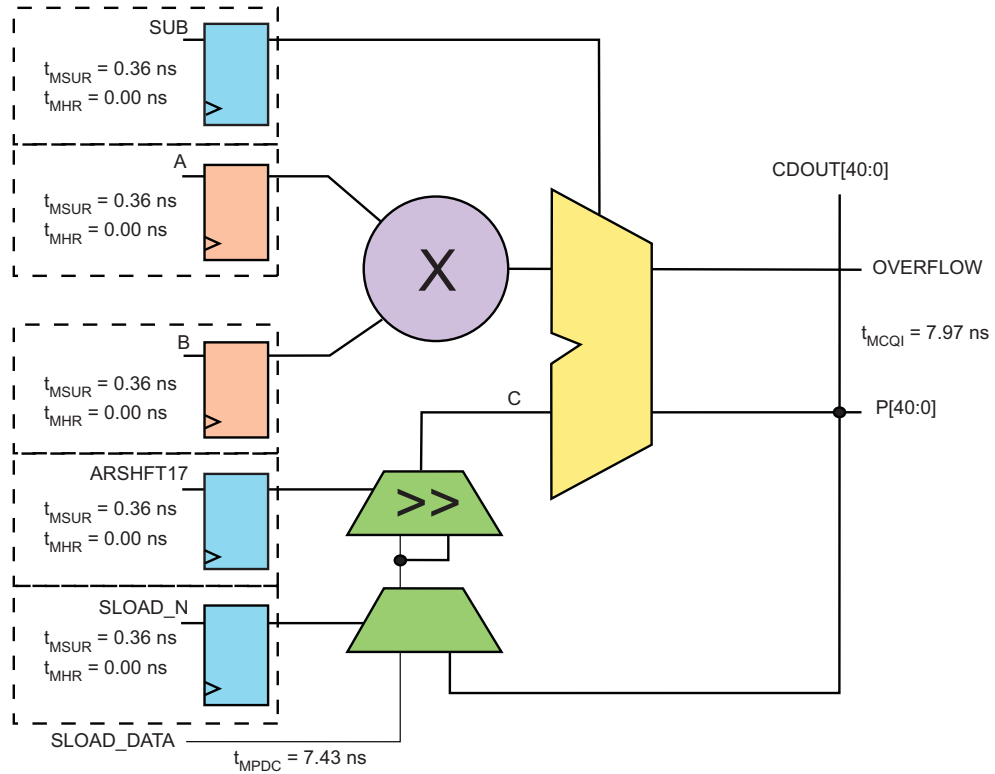

Figure 2-41 • Mathblock with Output Registers Bypassed and Input Registers Used

Table 2-69 • Mathblock with All Registers Bypassed
Worst-Case Military Conditions $V_{CCA} = 1.425\text{ V}$, $T_J = 125^\circ\text{C}$

Parameter	Description	Std. Speed		Units
		Min.	Max.	
t_{MPDB}	A, B, control registers to any outputs propagation delay		8.69	ns
t_{MPDC}	Carry inputs to any outputs propagation delay		7.43	ns

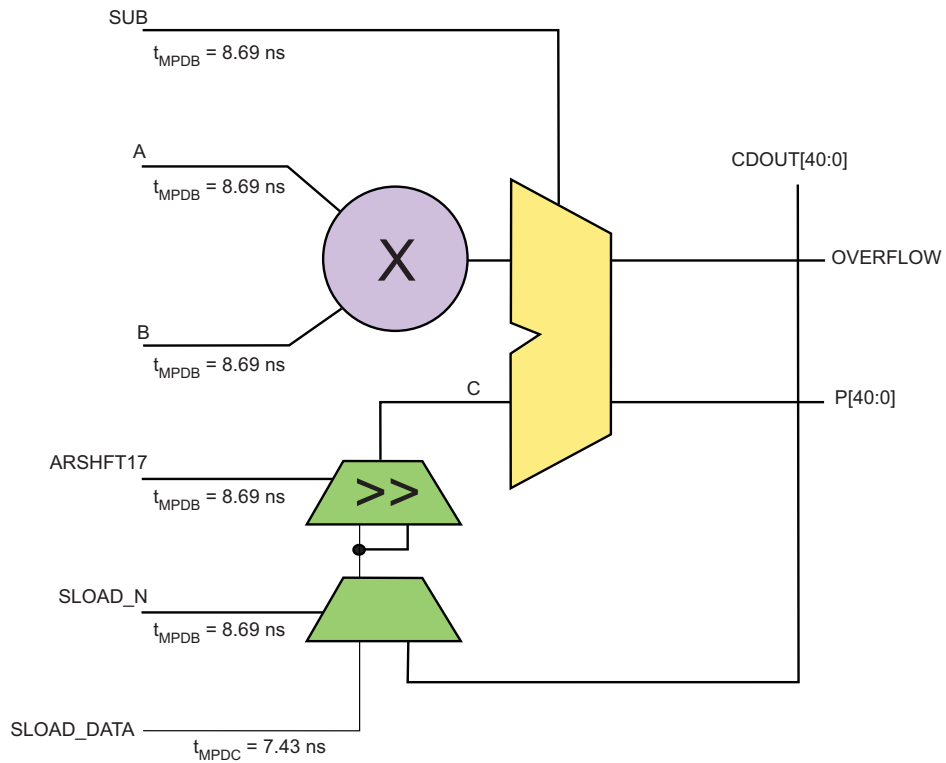

Figure 2-42 • Timing Diagram for Mathblock with All Registers Bypassed

Routing Specifications

Routing Resources

The routing structure found in RTAX-S/SL/DSP devices enables any logic module to be connected to any other logic module while retaining high performance. There are multiple paths and routing resources that can be used to route one logic module to another, both within a SuperCluster and elsewhere on the chip.

There are four primary types of routing within the RTAX-S/SL/DSP architecture: DirectConnect, CarryConnect, FastConnect and Vertical and Horizontal Routing.

DirectConnect

DirectConnects provide a high-speed connection between an R-cell and its adjacent C-cell (Figure 2-43). This connection can be made from DCOUT of the C-cell to DCIN of the R-cell by configuring of the S1 line of the R-cell. This provides a connection that does not require an antifuse and has a delay of less than 0.1 ns.

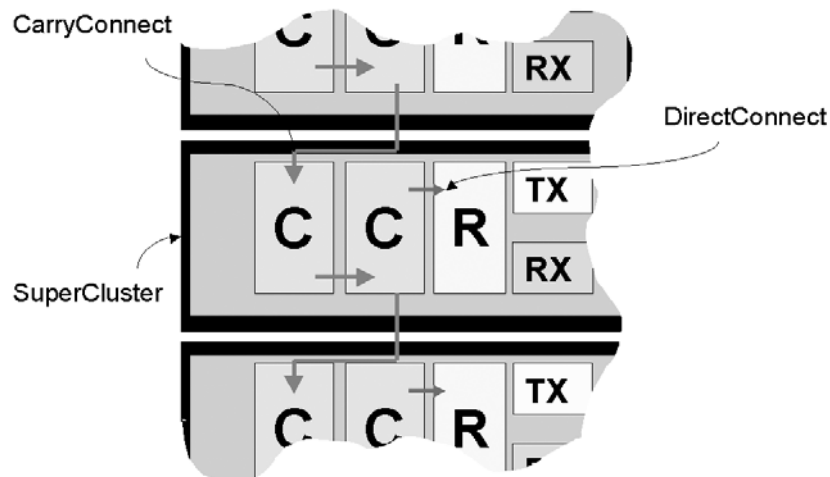

Figure 2-43 • DirectConnect and CarryConnect

CarryConnect

CarryConnects are used to build carry chains for arithmetic functions (Figure 2-43). The FCO output of the right C-cell of a two-C-cell Cluster drives the FCI input of the left C-cell in the two-C-cell Cluster immediately below it. This pattern continues down both sides of each SuperCluster column.

Similar to the DirectConnects, CarryConnects can be built without an antifuse connection. This connection has a delay of less than 0.1 ns from the FCO of one two-C-cell Cluster to the FCI of the two-C-cell Cluster immediately below it (see the "Carry-Chain Logic" on page 2-85 for more information).

FastConnect

For high-speed routing of logic signals, FastConnects can be used to build a short distance connection using a single antifuse (Figure 2-44 on page 2-98). FastConnects provide a maximum delay of 0.4 ns. The outputs of each logic module connect directly to the Output Tracks within a SuperCluster. Signals on the Output Tracks can then be routed through a single antifuse connection to drive the inputs of logic modules either within one SuperCluster or in the SuperCluster immediately below it.

Vertical and Horizontal Routing

Vertical and Horizontal Tracks provide both local and long distance routing (Figure 2-45 on page 2-98). These tracks are composed of both short-distance, segmented routing and across-chip routing tracks (segmented at core tile boundaries). The short-distance, segmented routing resources can be concatenated through antifuse connections to build longer routing tracks.

These short-distance routing tracks can be used within and between SuperClusters or between modules of non-adjacent SuperClusters. They can be connected to the Output Tracks and to any logic module input (R-cell, C-cell, Buffer, and TX module).

The across-chip horizontal and vertical routing provides long-distance, routing resources. These resources interface with the rest of the routing structures through the RX and TX modules (Figure 2-45). The RX module is used to drive signals from the across-chip horizontal and vertical routing to the Output Tracks within the SuperCluster. The TX module is used to drive vertical and horizontal across-chip routing from either short-distance horizontal tracks or from Output Tracks. The TX module can also be used to drive signals from vertical across-chip tracks to horizontal across-chip tracks and vice versa.

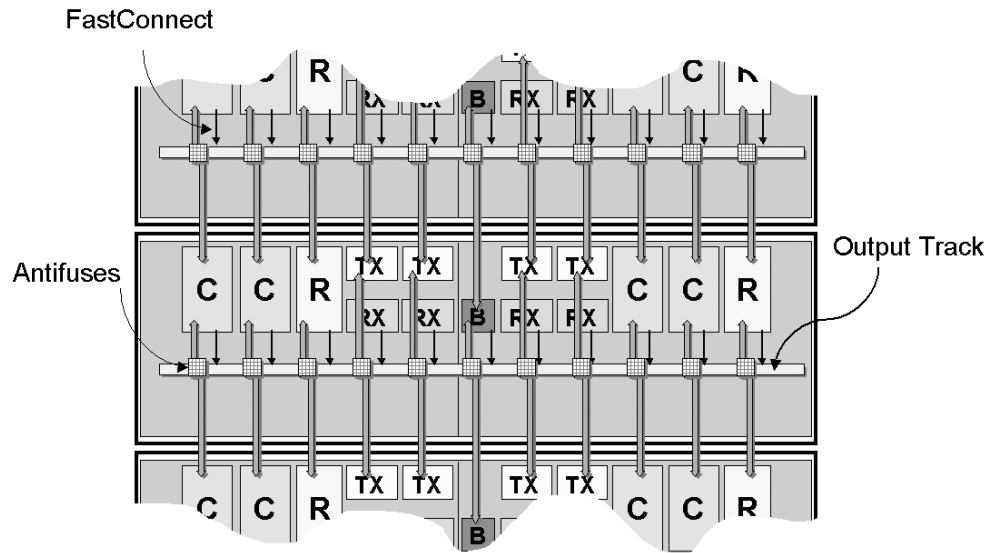

Figure 2-44 • FastConnect Routing

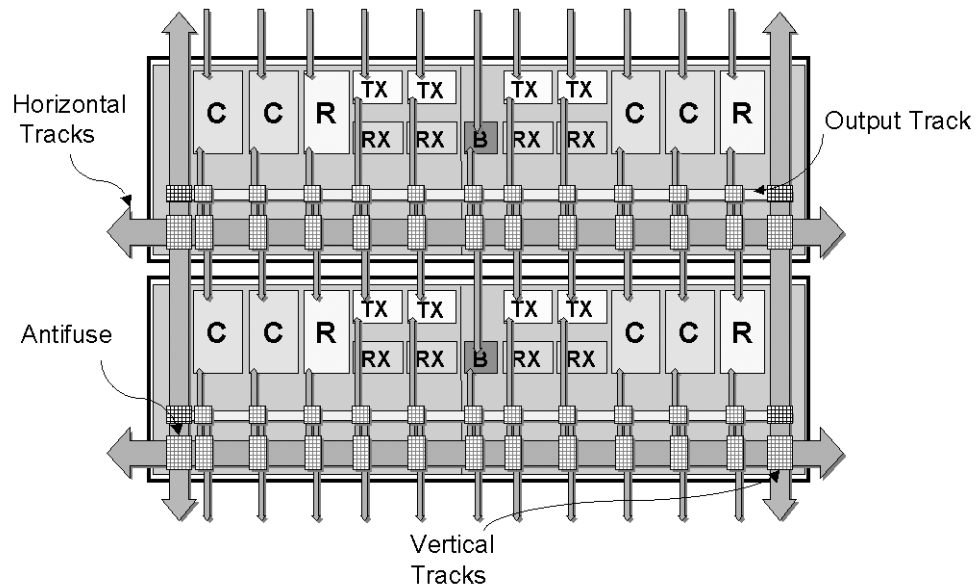

Figure 2-45 • Horizontal and Vertical Tracks

Timing Characteristics

Table 2-70 • RTAX250S/SL (Worst-Case Military Conditions VCCA = 1.4 V, VCCI = 3.0 V, T_J = 125°C)

Parameter	Description	-1 Speed		Std. Speed		Unit
		Min.	Max.	Min.	Max.	
Predicted Routing Delays						
t _{DC}	Direct connect		0.08		0.07	ns
t _{FC}	Fast connect F01		0.24		0.29	ns
t _{RD1}	Fanout 1		0.66		0.77	ns
t _{RD2}	Fanout 2		0.84		0.99	ns
t _{RD3}	Fanout 3		1.07		1.25	ns
t _{RD4}	Fanout 4		1.38		1.62	ns
t _{RD5}	Fanout 5		1.45		1.7	ns
t _{RD6}	Fanout 6		2.08		2.44	ns
t _{RD7}	Fanout 7		2.26		2.66	ns
t _{RD8}	Fanout 8		2.44		2.87	ns
t _{RD9}	Fanout 9		2.87		3.37	ns
t _{RD10}	Fanout 10		3.3		3.88	ns

Table 2-71 • RTAX1000S/SL (Worst-Case Military Conditions VCCA = 1.4 V, VCCI = 3.0 V, T_J = 125°C)

Parameter	Description	-1 Speed		Std. Speed		Unit
		Min.	Max.	Min.	Max.	
Predicted Routing Delays						
t _{DC}	Direct connect		0.08		0.07	ns
t _{FC}	Fast connect F01		0.24		0.29	ns
t _{RD1}	Fanout 1		0.66		0.77	ns
t _{RD2}	Fanout 2		0.84		0.99	ns
t _{RD3}	Fanout 3		1.07		1.25	ns
t _{RD4}	Fanout 4		1.38		1.62	ns
t _{RD5}	Fanout 5		1.45		1.7	ns
t _{RD6}	Fanout 6		2.08		2.44	ns
t _{RD7}	Fanout 7		2.26		2.66	ns
t _{RD8}	Fanout 8		2.44		2.87	ns
t _{RD9}	Fanout 9		2.87		3.37	ns
t _{RD10}	Fanout 10		3.3		3.88	ns

Table 2-72 • RTAX2000S/SL (Worst-Case Military Conditions VCCA = 1.4 V, VCCI = 3.0 V, T_J = 125°C)

Parameter	Description	-1 Speed		Std. Speed		Unit
		Min.	Max.	Min.	Max.	
Predicted Routing Delays						
t _{DC}	Direct connect		0.08		0.07	ns
t _{FC}	Fast connect F01		0.24		0.29	ns
t _{RD1}	Fanout 1		0.66		0.77	ns
t _{RD2}	Fanout 2		0.84		0.99	ns
t _{RD3}	Fanout 3		1.07		1.25	ns
t _{RD4}	Fanout 4		1.38		1.62	ns
t _{RD5}	Fanout 5		1.45		1.70	ns
t _{RD6}	Fanout 6		2.08		2.44	ns
t _{RD7}	Fanout 7		2.26		2.66	ns
t _{RD8}	Fanout 8		2.44		2.87	ns
t _{RD9}	Fanout 9		2.87		3.37	ns
t _{RD10}	Fanout 10		3.30		3.88	ns

Table 2-73 • RTAX2000D (Worst-Case Military Conditions VCCA = 1.4 V, VCCI = 3.0 V, T_J = 125°C)

Parameter	Description	Std. Speed		Unit
		Min.	Max.	
Predicted Routing Delays				
t _{DC}	Direct connect		0.07	ns
t _{FC}	Fast connect F01		0.29	ns
t _{RD1}	Fanout 1		0.77	ns
t _{RD2}	Fanout 2		0.99	ns
t _{RD3}	Fanout 3		1.25	ns
t _{RD4}	Fanout 4		1.62	ns
t _{RD5}	Fanout 5		1.70	ns
t _{RD6}	Fanout 6		2.44	ns
t _{RD7}	Fanout 7		2.66	ns
t _{RD8}	Fanout 8		2.87	ns
t _{RD9}	Fanout 9		3.37	ns
t _{RD10}	Fanout 10		3.88	ns

Table 2-74 • RTAX4000S (Worst-Case Military Conditions VCCA = 1.4 V, VCCI = 3.0 V, T_J = 125°C)

Parameter	Description	-1 Speed		Std. Speed		Unit
		Min.	Max.	Min.	Max.	
Predicted Routing Delays						
t _{DC}	Direct connect		0.06		0.07	ns
t _{FC}	Fast connect F01		0.26		0.29	ns
t _{RD1}	Fanout 1		0.69		0.77	ns
t _{RD2}	Fanout 2		0.89		0.99	ns
t _{RD3}	Fanout 3		1.13		1.25	ns
t _{RD4}	Fanout 4		1.46		1.62	ns
t _{RD5}	Fanout 5		1.53		1.7	ns
t _{RD6}	Fanout 6		2.20		2.44	ns
t _{RD7}	Fanout 7		2.39		2.66	ns
t _{RD8}	Fanout 8		2.58		2.87	ns
t _{RD9}	Fanout 9		3.03		3.37	ns
t _{RD10}	Fanout 10		3.49		3.88	ns

Table 2-75 • RTAX4000D (Worst-Case Military Conditions VCCA = 1.4 V, VCCI = 3.0 V, T_J = 125°C)

Parameter	Description	Std. Speed		Unit
		Min.	Max.	
Predicted Routing Delays				
t _{DC}	Direct connect		0.07	ns
t _{FC}	Fast connect F01		0.29	ns
t _{RD1}	Fanout 1		0.77	ns
t _{RD2}	Fanout 2		0.99	ns
t _{RD3}	Fanout 3		1.25	ns
t _{RD4}	Fanout 4		1.62	ns
t _{RD5}	Fanout 5		1.7	ns
t _{RD6}	Fanout 6		2.44	ns
t _{RD7}	Fanout 7		2.66	ns
t _{RD8}	Fanout 8		2.87	ns
t _{RD9}	Fanout 9		3.37	ns
t _{RD10}	Fanout 10		3.88	ns

Global Resources

One of the most important aspects of any FPGA architecture is its global resources or clocks. The RTAX-S/SL family provides the user with flexible and easy-to-use global resources, without the limitations normally found in other FPGA architectures. In addition, these global resources have been hardened to improve SEU performance.

The RTAX-S/SL architecture contains two types of global resources, the HCLK (hardwired clock) and CLK (routed clock). Every RTAX-S/SL device is provided with four HCLKs and four CLKs for a total of eight clocks, regardless of device density.

Hardwired Clocks

The hardwired (HCLK) is a low-skew network that can directly drive the clock inputs of all sequential modules (R-cells, I/O registers and embedded RAM/FIFOs) in the device with no antifuse in the path. All four HCLKs are available everywhere on the chip.

Timing Characteristics

Table 2-76 • RTAX250S/SL (Worst-Case Military Conditions VCCA = 1.425 V, VCCI = 3.0 V, T_J = 125°C)

Parameter	Description	-1 Speed		Std. Speed		Units
		Min.	Max.	Min.	Max.	
t _{HCKL}	Input Low to High		2.75		3.23	ns
t _{HCKH}	Input High to Low		2.94		3.45	ns

Table 2-77 • RTAX250S/SL Worst-Case MPW (VCCA = 1.575 V, VCCI = 3.6 V, T_J = 125°C)

Parameter	Description	-1 Speed		Std. Speed		Units
		Min.	Max.	Min.	Max.	
t _{HPWH}	Minimum Pulse width High	0.77		0.77		ns
t _{HPWL}	Minimum Pulse width Low	0.26		0.26		ns
f _{HMAX} ¹	Maximum frequency		649		649	MHz

Note: ¹f_{HMAX} = 1000 / (2 * (MAX(t_{HPWH}, t_{HPWL})))

Table 2-78 • RTAX1000S/SL (Worst-Case Military Conditions VCCA = 1.425 V, VCCI = 3.0 V, T_J = 125°C)

Parameter	Description	-1 Speed		Std. Speed		Units
		Min.	Max.	Min.	Max.	
t _{HCKL}	Input Low to High		3.64		4.28	ns
t _{HCKH}	Input High to Low		3.47		4.08	ns

Table 2-79 • RTAX1000S/SL Worst-Case MPW (VCCA = 1.575 V, VCCI = 3.6 V, T_J = 125°C)

Parameter	Description	-1 Speed		Std. Speed		Units
		Min.	Max.	Min.	Max.	
t _{HPWH}	Minimum Pulse width High	0.86		0.86		ns
t _{HPWL}	Minimum Pulse width Low	0.31		0.31		ns
f _{HMAX} ¹	Maximum frequency		581		581	MHz

Note: ¹f_{HMAX} = 1000 / (2 * (MAX(t_{HPWH}, t_{HPWL})))

Table 2-80 • RTAX2000S/SL (Worst-Case Military Conditions VCCA = 1.425 V, VCCI = 3.0 V, T_J = 125°C)

Parameter	Description	-1 Speed		Std. Speed		Units
		Min.	Max.	Min.	Max.	
t _{HCKL}	Input Low to High		3.64		4.28	ns
t _{HCKH}	Input High to Low		3.47		4.08	ns

Table 2-81 • RTAX2000S/SL Worst-Case MPW (VCCA = 1.575 V, VCCI = 3.6 V, T_J = 125°C)

Parameter	Description	-1 Speed		Std. Speed		Units
		Min.	Max.	Min.	Max.	
t _{HPWH}	Minimum Pulse width High	0.77		0.77		ns
t _{HPWL}	Minimum Pulse width Low	0.26		0.26		ns
f _{HMAX} ¹	Maximum frequency		649		649	MHz

Note: $f_{HMAX} = 1000 / (2 * (MAX(t_{HPWH}, t_{HPWL})))$

Table 2-82 • RTAX4000S (Worst-Case Military Conditions VCCA = 1.425 V, VCCI = 3.0 V, T_J = 125°C)

Parameter	Description	-1 Speed		Std. Speed		Units
		Min.	Max.	Min.	Max.	
t _{HCKL}	Input Low to High		5.67		6.28	ns
t _{HCKH}	Input High to Low		5.47		6.06	ns

Table 2-83 • RTAX4000S Worst-Case MPW (VCCA = 1.575 V, VCCI = 3.6 V, T_J = 125°C)

Parameter	Description	-1 Speed		Std. Speed		Units
		Min.	Max.	Min.	Max.	
t _{HPWH}	Minimum Pulse width High	TBD		TBD		ns
t _{HPWL}	Minimum Pulse width Low	TBD		TBD		ns
f _{HMAX} ¹	Maximum frequency		TBD		TBD	MHz

Note: $f_{HMAX} = 1000 / (2 * (MAX(t_{HPWH}, t_{HPWL})))$

Table 2-84 • RTAX2000D Worst-Case Military Conditions (VCCA = 1.425 V, VCCI = 3.0 V, T_J = 125°C)

Parameter	Description	'Std.' Speed		Units
		Min.	Max.	
t _{HCKL}	Input Low to High		4.28	ns
t _{HCKH}	Input High to Low		4.08	ns
f _{HCKSW}	Maximum skew		TBD	ns

Table 2-85 • RTAX2000D Worst-Case MPW (VCCA = 1.575 V, VCCI = 3.6 V, T_J = 125°C)

Parameter	Description	Std. Speed		Units
		Min.	Max.	
t _{HPWH}	Minimum Pulse width High	0.77		ns
t _{HPWL}	Minimum Pulse width Low	0.26		ns
f _{HMAX} ¹	Maximum frequency		649	MHz

Note: $f_{HMAX} = 1000 / (2 * (MAX(t_{HPWH}, t_{HPWL})))$

Table 2-86 • RTAX4000D Worst-Case Military Conditions (VCCA = 1.425 V, VCCI = 3.0 V, T_J = 125°C)

Parameter	Description	Std. Speed		Units
		Min.	Max.	
t _{HCKL}	Input Low to High		6.28	ns
t _{HCKH}	Input High to Low		6.06	ns
f _{HCKSW}	Maximum skew		TBD	ns

Note: $*f_{HMAX} = 1000 / (2 * (MAX(t_{HPWH}, t_{HPWL})))$

Table 2-87 • RTAX4000D Worst-Case MPW (VCCA = 1.575 V, VCCI = 3.6 V, T_J = 125°C)

Parameter	Description	Std. Speed		Units
		Min.	Max.	
t _{HPWH}	Minimum Pulse width High	TBD		ns
t _{HPWL}	Minimum Pulse width Low	TBD		ns
f _{HMAX} ¹	Maximum frequency		TBD	MHz

Note: $*f_{HMAX} = 1000 / (2 * (MAX(t_{HPWH}, t_{HPWL})))$

Routed Clocks

The routed clock (CLK) is a low-skew network that can drive the clock inputs of all sequential modules in the device (logically equivalent to the HCLK), but has the added flexibility in that it can drive the S0 (Enable), S1, PSET, and CLR input of a register (R-cells and I/O registers) as well as any of the inputs of any C-cell in the device. This allows CLKs to be used not only as clocks, but also for other global signals or high fanout nets. All four CLKs are available everywhere on the chip.

Timing Characteristics

Timing characteristics are shown in Table 2-88 through Table 2-95.

Table 2-88 • RTAX250S/SL (Worst-Case Military Conditions VCCA = 1.425 V, VCCI = 3.0 V, T_J = 125°C)

Parameter	Description	-1 Speed		Std. Speed		Units
		Min.	Max.	Min.	Max.	
t _{RCKL}	Input Low to High		2.77		3.25	ns
t _{RCKH}	Input High to Low		2.91		3.42	ns
t _{RCKSW}	Maximum skew – 16 Loads		1.40		1.64	ns
	Maximum skew – 24 Loads		1.80		2.12	ns

Table 2-89 • RTAX250S/SL Worst-Case MPW (VCCA = 1.575 V, VCCI = 3.6 V, T_J = 125°C)

Parameter	Description	-1 Speed		Std. Speed		Units
		Min.	Max.	Min.	Max.	
t _{RPWH}	Minimum Pulse width High	0.79		0.79		ns
t _{RPWL}	Minimum Pulse width Low	0.27		0.27		ns
f _{RMAX} ¹	Maximum frequency		633		633	MHz

Note: ¹f_{RMAX} = 1000 / (2 * (MAX(t_{RPWH}, t_{RPWL})))

Table 2-90 • RTAX1000S/SL (Worst-Case Military Conditions VCCA = 1.425 V, VCCI = 3.0 V, T_J = 125°C)

Parameter	Description	-1 Speed		Std. Speed		Units
		Min.	Max.	Min.	Max.	
t _{RCKL}	Input Low to High		3.71		4.36	ns
t _{RCKH}	Input High to Low		3.53		4.14	ns
t _{RCKSW}	Maximum skew – 16 Loads		1.39		1.63	ns
	Maximum skew – 24 Loads		1.80		2.11	ns
	Maximum skew – 36 Loads		1.86		2.19	ns

Table 2-91 • RTAX1000S/SL Worst-Case MPW (VCCA = 1.575 V, VCCI = 3.6 V, T_J = 125°C)

Parameter	Description	-1 Speed		Std. Speed		Units
		Min.	Max.	Min.	Max.	
t _{RPWH}	Minimum Pulse width High	1.04		1.04		ns
t _{RPWL}	Minimum Pulse width Low	0.33		0.33		ns
f _{RMAX} ¹	Maximum frequency		481		481	MHz

Note: ¹f_{RMAX} = 1000 / (2 * (MAX(t_{RPWH}, t_{RPWL})))

Table 2-92 • RTAX2000S/SL (Worst-Case Military Conditions VCCA = 1.425 V, VCCI = 3.0 V, T_J = 125°C)

Parameter	Description	-1 Speed		Std. Speed		Units
		Min.	Max.	Min.	Max.	
t _{RCKL}	Input Low to High		3.71		4.36	ns
t _{RCKH}	Input High to Low		3.53		4.14	ns
t _{RCKSW}	Maximum skew – 16 Loads		1.39		1.63	ns
	Maximum skew – 24 Loads		1.80		2.11	ns
	Maximum skew – 36 Loads		2.11		2.48	ns

Table 2-93 • RTAX2000S/SL Worst-Case MPW (VCCA = 1.575 V, VCCI = 3.6 V, T_J = 125°C)

Parameter	Description	-1 Speed		Std. Speed		Units
		Min.	Max.	Min.	Max.	
t _{RPWH}	Minimum Pulse width High	0.79		0.79		ns
t _{RPWL}	Minimum Pulse width Low	0.27		0.27		ns
f _{RMAX} ¹	Maximum frequency		633		633	MHz

Note: $*f_{RMAX} = 1000 / (2 * (\text{MAX}(t_{RPWH}, t_{RPWL})))$

Table 2-94 • RTAX4000S (Worst-Case Military Conditions VCCA = 1.425 V, VCCI = 3.0 V, T_J = 125°C)

Parameter	Description	-1 Speed		Std. Speed		Units
		Min.	Max.	Min.	Max.	
t _{RCKL}	Input Low to High		5.77		6.39	ns
t _{RCKH}	Input High to Low		5.56		6.16	ns
t _{RCKSW}	Maximum skew – 16 Loads		1.47		1.62	ns
	Maximum skew – 24 Loads		1.90		2.10	ns
	Maximum skew – 36 Loads		1.94		2.15	ns

Table 2-95 • RTAX4000S Worst-Case MPW (VCCA = 1.575 V, VCCI = 3.6 V, T_J = 125°C)

Parameter	Description	-1 Speed		Std. Speed		Units
		Min.	Max.	Min.	Max.	
t _{RPWH}	Minimum Pulse width High	TBD		TBD		ns
t _{RPWL}	Minimum Pulse width Low	TBD		TBD		ns
f _{RMAX} ¹	Maximum frequency		TBD		TBD	MHz

Note: $*f_{RMAX} = 1000 / (2 * (\text{MAX}(t_{RPWH}, t_{RPWL})))$

Table 2-96 • RTAX2000D (Worst-Case Military Conditions VCCA = 1.425 V, VCCI = 3.0 V, T_J = 125°C)

Parameter	Description	Std. Speed		Units
		Min.	Max.	
t _{RCKL}	Input Low to High		4.36	ns
t _{RCKH}	Input High to Low		4.14	ns
t _{RCKSW}	Maximum skew – 16 Loads		1.63	ns
	Maximum skew – 24 Loads		2.11	ns
	Maximum skew – 36 Loads		2.48	ns

Table 2-97 • RTAX2000D Worst-Case MPW (VCCA = 1.575 V, VCCI = 3.6 V, T_J = 125°C)

Parameter	Description	Std. Speed		Units
		Min.	Max.	
t _{RPWH}	Minimum Pulse width High	0.79		ns
t _{RPWL}	Minimum Pulse width Low	0.27		ns
f _{RMAX} ¹	Maximum frequency		633	MHz

Note: $*f_{RMAX} = 1000 / (2 * (MAX(t_{RPWH}, t_{RPWL})))$

Table 2-98 • RTAX4000D (Worst-Case Military Conditions VCCA = 1.425 V, VCCI = 3.0 V, T_J = 125°C)

Parameter	Description	'Std.' Speed		Units
		Min.	Max.	
t _{RCKL}	Input Low to High		6.39	ns
t _{RCKH}	Input High to Low		6.16	ns
t _{RCKSW}	Maximum skew – 16 Loads		1.62	ns
	Maximum skew – 24 Loads		2.10	ns
	Maximum skew – 36 Loads		2.15	ns

Table 2-99 • RTAX4000D Worst-Case MPW (VCCA = 1.575 V, VCCI = 3.6 V, T_J = 125°C)

Parameter	Description	Std. Speed		Units
		Min.	Max.	
t _{RPWH}	Minimum Pulse width High	TBD		ns
t _{RPWL}	Minimum Pulse width Low	TBD		ns
f _{RMAX} ¹	Maximum frequency		TBD	MHz

Note: $*f_{RMAX} = 1000 / (2 * (MAX(t_{RPWH}, t_{RPWL})))$

Global Resource Distribution

At the root of each global resource is a ClockDistBuffer (CDB). There are two groups of four CDBs for every device. One group, located at the center of the north edge (in the I/O ring) of the chip, sources the four HCLKs. The second group, located at the center of the south edge (again in the I/O ring), sources the four CLKs (Figure 2-46).

Regardless of the type of global resource, HCLK or CLK, each of the eight resources reach the ClockTileDist (CTD) Cluster located at the center of every core tile with zero skew. From the ClockTileDist Cluster, all four HCLKs and four CLKs are distributed through the core tile (Figure 2-47).

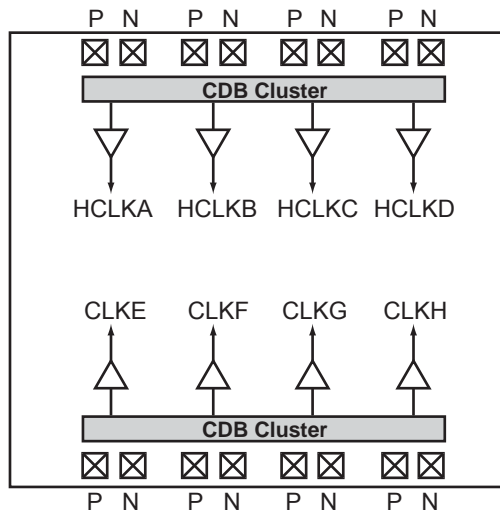

Figure 2-46 • ClockDistBuffer Group

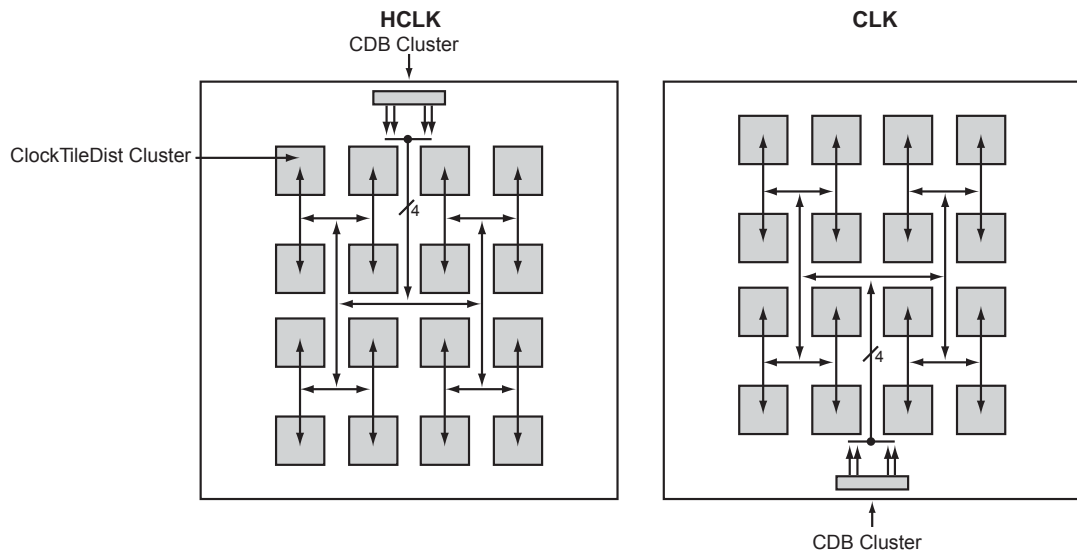

Figure 2-47 • Example of HCLK and CLK Distributions on the RTAX2000S/SL

The ClockTileDist Cluster contains an HCLKMux (HM) module for each of the four HCLK trees and a CLKMux (CM) module for each of the CLK trees. The HCLK branches then propagate horizontally through the middle of the core tile to HCLKColDist (HD) modules in every SuperCluster column. The CLK branches propagate vertically through the center of the core tile to CLKRowDist (RD) modules in every SuperCluster row. Together, the HCLK and CLK branches provide for a low-skew global fanout within the core tile (Figure 2-48 and Figure 2-49).

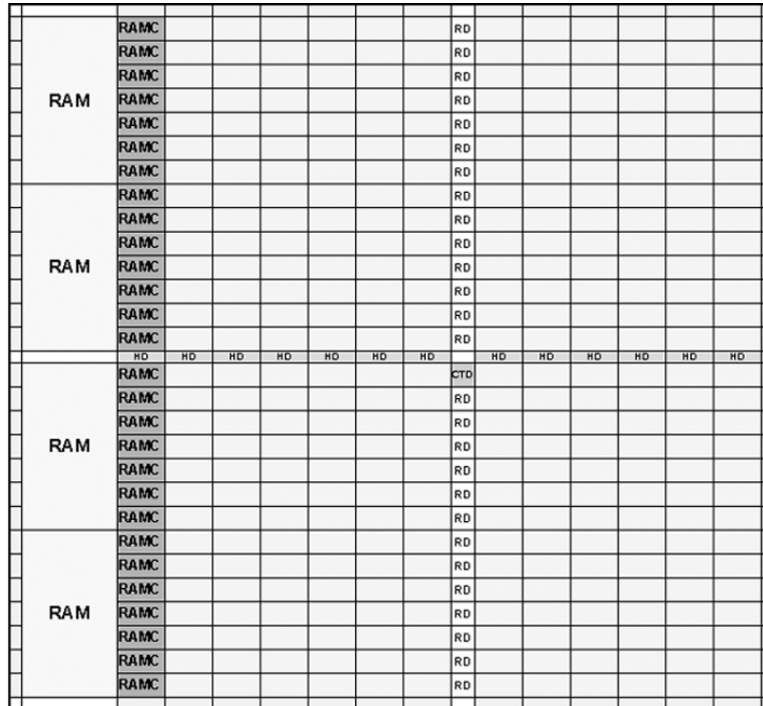

Figure 2-48 • CTD, CD, and HD Module Layout

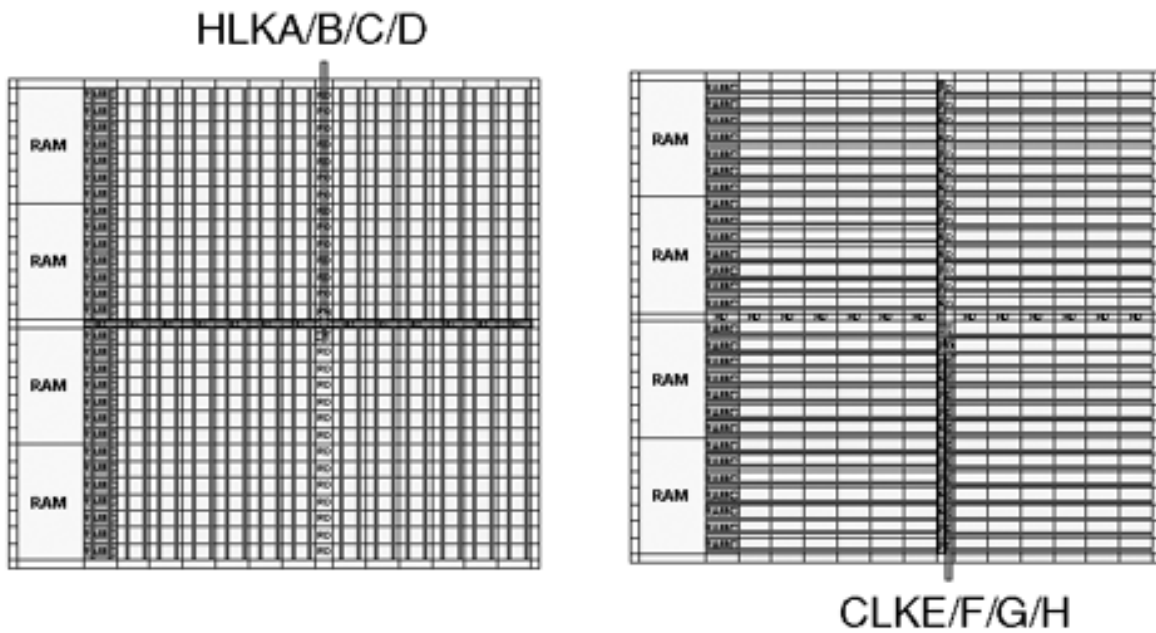

Figure 2-49 • HCLK and CLK Distribution within a Core Tile

The HM and CM modules can select between:

- The HCLK or CLK source
- A local signal routed on generic routing resources

This allows each core tile to have eight clocks independent of the other core tiles in the device.

Both HCLK and CLK are segmentable, meaning that individual branches of the global resource can be used independently.

Like the HM and CM modules, the HD and RD modules can select between:

- The HCLK or CLK source from the HM or CM module, respectively
- A local signal routed on generic routing resources

Again, an unused input can be tied to ground for power savings.

The RTAX-S/SL architecture is capable of supporting a large number of local clocks. Refer to the [RTAX-S/SL Clocking Resource and Implementation](#) application note for more information.

Microsemi Designer software's place-and-route takes advantage of the segmented clock structure found in RTAX-S/SL devices by turning off any unused clock segments. This results in not only better performance but also lower power consumption. Future releases of Designer will give the user greater control over these individual clock segments.

Global Resource Access Macros

Global resources can be driven by one of three sources: external pad(s) or an internal net. These connections can be made by using one of two types of macros: CLKBUF and CLKINT.

CLKBUF and HCLKBUF

CLKBUF (HCLKBUF) is used to drive a CLK (HCLK) from external pads. These macros can be used either generically or with the specific I/O standard desired (e.g., CLKBUF_LVCMOS25, HCLKBUF_LVDS, etc.) (Figure 2-50).

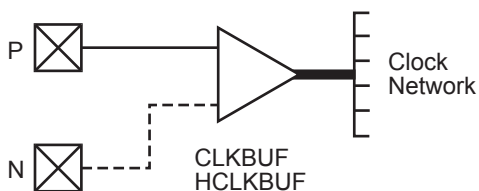

Figure 2-50 • CLKBUF and HCLKBUF

Package pins CLKEP and CLKEN are associated with CLKE; package pins HCLKAP and HCLKAN are associated with HCLKA, etc.

Note that when CLKBUF (HCLKBUF) is used with a single-ended I/O standard, it must be tied to the P-pad of the CLK (HCLK) package pin. In this case, the CLK (HCLK) N-pad can be used for user signals.

CLKINT and HCLKINT

CLKINT (HCLKINT) is used to access the CLK (HCLK) resource internally from the user signals (Figure 2-51).

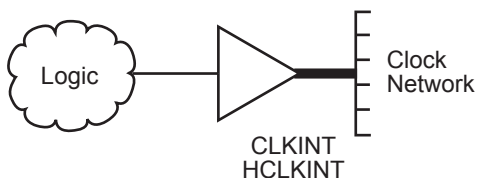

Figure 2-51 • CLKINT and HCLKINT

Embedded Memory

The RTAX-S/SL architecture provides extensive, high-speed memory resources to the user. Each 4,608-bit block of RAM contains its own embedded FIFO controller, allowing the user to configure each block as either RAM or FIFO.

To meet the needs of high performance designs, the memory blocks operate in synchronous mode for both read and write operations. However, the read and write clocks are completely independent, and each may operate beyond 500 MHz.

No additional core logic resources are required to cascade the address and data buses when cascading different RAM blocks. Dedicated routing runs along each column of RAM to facilitate cascading.

The RTAX-S/SL memory block includes dedicated FIFO control logic to generate internal addresses and external flag logic (FULL, EMPTY, AFULL, AEMPTY). Since read and write operations can occur asynchronously to one another, special control circuitry is included to prevent metastability, overflow, and underflow. A block diagram of the memory module is illustrated in [Figure 2-52](#).

During RAM operation, read (RA) and write (WA) addresses are sourced by user logic and the FIFO controller is ignored. In FIFO mode, the internal addresses are generated by the FIFO controller and routed to the RAM array by internal MUXes. Enables with programmable polarity are provided to create upper address bits for cascading up to 16 memory blocks. When cascading memory blocks, the bussed signals WA, WD, WEN, RA, RD, and REN are internally linked to eliminate external routing congestion.

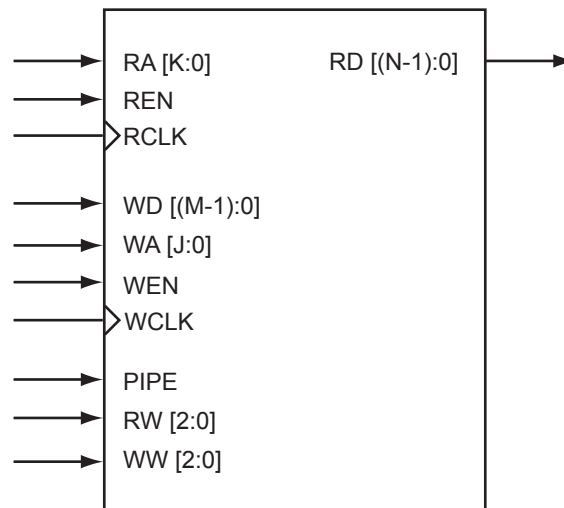

Figure 2-52 • RTAX-S/SL Memory Module

RAM

Each memory block consists of 4,608 bits that can be organized as 128x36, 256x18, 512x9, 1kx4, 2kx2, or 4kx1 and are cascadable to create larger memory sizes. This allows built-in bus width conversion ([Table 2-100](#)). Each block has independent read and write ports, which enable simultaneous read and write operations. Simultaneous read and write operations to the same address is not supported.

Table 2-100 • Memory Block WxD Options

Data-Word (in bits)	Depth	Address Bus	Data Bus
1	4,096	RA/WA[11:0]	RD/WD[0]
2	2,048	RA/WA[10:0]	RD/WD[1:0]
4	1,024	RA/WA[9:0]	RD/WD[3:0]
9	512	RA/WA[8:0]	RD/WD[8:0]
18	256	RA/WA[7:0]	RD/WD[17:0]
36	128	RA/WA[6:0]	RD/WD[35:0]

Clocks

The RCLK and the WCLK have independent source polarity selection and can be sourced by any global or local signal.

RAM Configurations

The RTAX-S/SL architecture allows the read side and write side of RAMs to be organized independently, allowing for bus conversion. For example, the write side can be set to 256x18 and the read side to 512x9.

Both the write width and read width for the RAM blocks can be specified independently and changed dynamically with the WW (write width) and RW (read width) pins. The available DxW configurations are: 128x36, 256x18, 512x9, 1kx4, 2kx2, and 4kx1. The allowable RW and WW values are shown in [Table 2-102](#).

When widths of one, two, and four are selected, the ninth bit is unused. For example, when writing nine-bit values and reading four-bit values, only the first four bits and the second four bits of each nine-bit value are addressable for read operations. The ninth bit is not accessible. Conversely, when writing four-bit values and reading nine-bit values, the ninth bit of a read operation will be undefined.

Note that the RAM blocks employ little-endian byte order for read and write operations.

Table 2-101 • RAM Signal Description

Signal	Direction	Description
WCLK	Input	Write clock (can be active on either edge).
WA[J:0]	Input	Write address bus. The value J is dependent on the RAM configuration and the number of cascaded memory blocks. The valid range for J is from 6 to 15.
WD[M-1:0]	Input	Write data bus. The value M is dependent on the RAM configuration and can be 1, 2, 4, 9, 18, or 36.
RCLK	Input	Read clock (can be active on either edge).
RA[K:0]	Input	Read address bus. The value K is dependent on the RAM configuration and the number of cascaded memory blocks. The valid range for K is from 6 to 15.
RD[N-1:0]	Output	Read data bus. The value N is dependent on the RAM configuration and can be 1, 2, 4, 9, 18, or 36.
REN	Input	Read enable. When this signal is valid on the active edge of the clock, data at location RA will be driven onto RD.
WEN	Input	Write enable. When this signal is valid on the active edge of the clock, WD data will be written at location WA.
RW[2:0]	Input	Width of the read operation dataword.
WW[2:0]	Input	Width of the write operation dataword.
PIPE	Input	Sets the pipeline option to be on or off.
DEPTH[3:0]	Input	Depth of the RAM blocks, which can be cascaded up to 16 blocks

Table 2-102 • Allowable RW and WW Values

RW(2:0)	WW(2:0)	D x W
000	000	4kx1
001	001	2kx2
010	010	1kx4
011	011	512x9
100	100	256x18
101	101	128x36
11x	11x	reserved

Modes of Operation

There are two read modes and one write mode:

1. Read Nonpipelined (synchronous – one clock edge):

In the standard read mode, new data is driven onto the RD bus in the clock cycle immediately following RA and REN valid. The read address is registered on the read-port active-clock edge and data appears at read-data after the RAM access time. Setting PIPE to OFF enables this mode.

2. Read Pipelined (synchronous – two clock edges):

The pipelined mode incurs an additional clock delay from address to data, but enables operation at a much higher frequency. The read-address is registered on the read-port active-clock edge, and the read data is registered and appears at RD after the second read clock edge. Setting PIPE to ON enables this mode.

3. Write (synchronous – one clock edge):

On the write active-clock edge, the write data are written into the SRAM at the write address when WEN is high. The setup time of the write address, write enables, and write data are minimal with respect to the write clock.

Write and read transfers are described with timing requirements beginning in ["Timing Characteristics" on page 2-115](#).

Enhancing SEU Performance

SRAM structures are inherently susceptible to upsets caused by high-energy particles encountered in space. High-energy particles can cause an SRAM cell to change state, resulting in the loss or corruption of a valuable data bit. To allow users to achieve high levels of SEU performance, Microsemi has developed an intellectual property (IP) core to enhance the SEU tolerance of the embedded SRAM within RTAX-S/SL.

This IP employs two upset-mitigation techniques:

- Error Detection and Correction (EDAC)
- A background memory-refresher, or scrubber

The EDAC IP employs the use of shortened Hamming Codes to provide the user with single-error correction/double-error detection (SEC/DED) capabilities. These shortened Hamming Codes provide the user with an implementation that has a reduced number of logic levels and less complexity than traditional Hamming Codes. The SmartGen-generated EDAC IP supports RAM widths of 8, 16, and 32 bits, with a variable RAM depth from 256 to 4k words.

The memory scrubber circuitry has also been embedded in the EDAC IP as an optional block. The scrubber circuitry periodically refreshes memory in the background to ensure that no corruption of its contents has taken place while the memory was not in use. The refresh rate can be set by the user.

The use of EDAC IP combined with the embedded memory scrubber circuitry, gives the RTAX-S/SL an SEU radiation performance level of better than 10^{-10} errors/bit-day. See the application note [Using EDAC RAM for RadTolerant RTAX-S/SL FPGAs and Accelerator FPGAs](#).

Timing Model and Waveforms

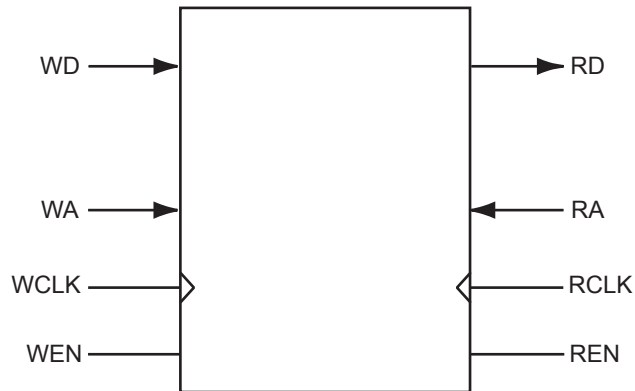

Figure 2-53 • SRAM Model

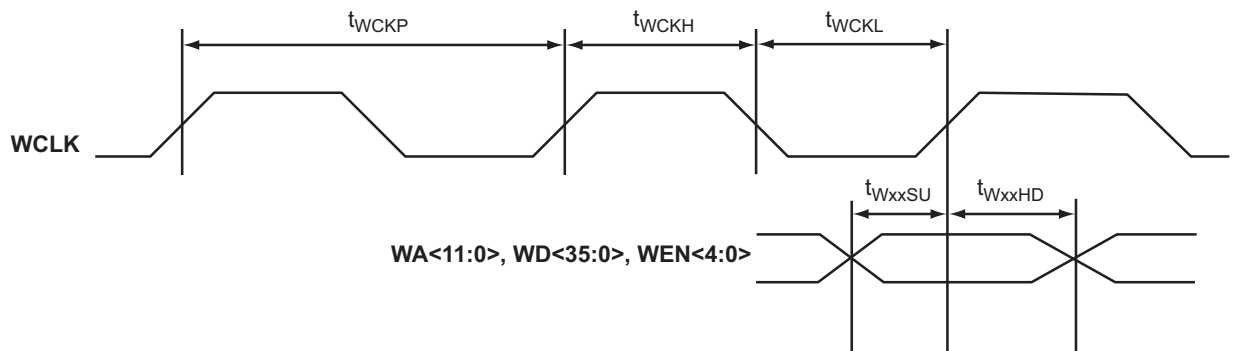

Figure 2-54 • RAM Write Timing Waveforms

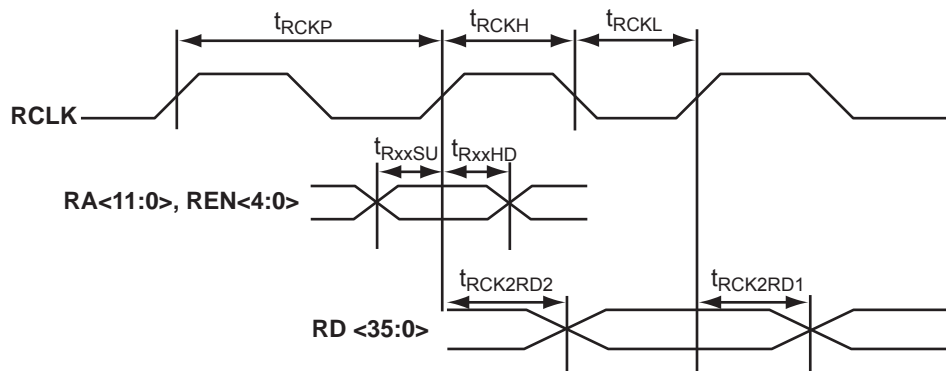

Figure 2-55 • RAM Read Timing Waveforms

Timing Characteristics

Table 2-103 • One RAM Block* (Worst-Case Military Conditions VCCA = 1.425 V, VCCI = 3.0 V, T_J = 125°C)

Parameter	Description	-1 Speed				Std. Speed		Units
		RTAX4000S/SL RTAX4000D/DL		RTAX250/1000/ 2000S/SL RTAX2000D/DL		All		
		Min.	Max.	Min.	Max.	Min.	Max.	
Write Mode								
t _{WDASU}	Write Data Setup vs. WCLK	1.51		1.42		1.67		ns
t _{WDAHD}	Write Data Hold vs. WCLK	0.31		0.29		0.34		ns
t _{WADSU}	Write Address Setup vs. WCLK	1.51		1.42		1.67		ns
t _{WADHD}	Write Address Hold vs. WCLK	0.00		0.00		0.00		ns
t _{WENSU}	Write Enable Setup vs. WCLK	1.51		1.42		1.67		ns
t _{WENHD}	Write Enable Hold vs. WCLK	0.31		0.29		0.34		ns
t _{WCKH}	WCLK Minimum High Pulse Width	0.75		0.75		0.75		ns
t _{WCLKL}	WCLK Minimum Low Pulse Width	0.88		0.88		0.88		ns
t _{WCKP}	WCLK Minimum Period	1.63		1.63		1.63		ns
Read Mode								
t _{RASU}	Read Address Setup vs. RCLK	1.13		1.06		1.25		ns
t _{RADHD}	Read Address Hold vs. RCLK	0.00		0.00		0.00		ns
t _{RENSU}	Read Enable Setup vs. RCLK	1.13		1.06		1.25		ns
t _{RENHD}	Read Enable Hold vs. RCLK	0.00		0.00		0.00		ns
t _{RCK2RD1}	RCLK-To-OUT (Pipelined)		1.85		1.74		2.05	ns
t _{RCK2RD2}	RCLK-To-OUT (Non-Pipelined)		3.02		2.85		3.35	ns
t _{RCLKH}	RCLK Minimum High Pulse Width	0.77		0.77		0.77		ns
t _{RCLKL}	RCLK Minimum Low Pulse Width	0.93		0.93		0.93		ns
t _{RCKP}	RCLK Minimum Period	1.70		1.70		1.70		ns

Note: *Timing data for this single block RAM has a depth of 4,096. For all other combinations, use Microsemi's SmartTime tool.

Table 2-104 • Two RAM Blocks* Are Cascaded (Worst-Case Military Conditions VCCA = 1.425 V, VCCI = 3.0 V, T_J = 125°C)

Parameter	Description	-1 Speed				Std. Speed		Units
		RTAX4000S/SL RTAX4000D/DL		RTAX250/1000/ 2000S/SL RTAX2000D/DL		All		
		Min.	Max.	Min.	Max.	Min.	Max.	
Write Mode								
t _{WDASU}	Write Data Setup vs. WCLK	1.95		1.83		2.16		ns
t _{WDAHD}	Write Data Hold vs. WCLK	0.00		0.00		0.00		ns
t _{WADSU}	Write Address Setup vs. WCLK	1.95		1.83		2.16		ns
t _{WADHD}	Write Address Hold vs. WCLK	0.00		0.00		0.00		ns
t _{WENSU}	Write Enable Setup vs. WCLK	1.95		1.83		2.16		ns
t _{WENHD}	Write Enable Hold vs. WCLK	0.00		0.00		0.00		ns
t _{WCKH}	WCLK Minimum High Pulse Width	0.75		0.75		0.75		ns
t _{WCLKL}	WCLK Minimum Low Pulse Width	1.76		1.76		1.76		ns
t _{WCKP}	WCLK Minimum Period	2.51		2.51		2.51		ns
Read Mode								
t _{RADSU}	Read Address Setup vs. RCLK	2.38		2.24		2.64		ns
t _{RADHD}	Read Address Hold vs. RCLK	0.00		0.00		0.00		ns
t _{RENSU}	Read Enable Setup vs. RCLK	2.38		2.24		2.64		ns
t _{RENHD}	Read Enable Hold vs. RCLK	0.00		0.00		0.00		ns
t _{RCK2RD1}	RCLK-To-OUT (Pipelined)		2.00		1.89		2.22	ns
t _{RCK2RD2}	RCLK-To-OUT (Non-Pipelined)		3.16		2.98		3.50	ns
t _{RCLKH}	RCLK Minimum High Pulse Width	0.73		0.73		0.73		ns
t _{RCLKL}	RCLK Minimum Low Pulse Width	1.89		1.89		1.89		ns
t _{RCKP}	RCLK Minimum Period	2.62		2.62		2.62		ns

Note: *Timing data for two cascaded RAM blocks uses a depth of 8,192. For all other combinations, use Microsemi's SmartTime tool.

Table 2-105 • Four RAM Blocks* Are Cascaded (Worst-Case Military Conditions VCCA = 1.425 V, VCCI = 3.0 V, T_J = 125°C)

Parameter	Description	-1 Speed				Std. Speed		Units
		RTAX4000S/SL RTAX4000D/DL		RTAX250/1000/ 2000S/SL RTAX2000D/DL		All		
		Min.	Max.	Min.	Max.	Min.	Max.	
Write Mode								
t _{WDASU}	Write Data Setup vs. WCLK	3.31		3.12		3.67		ns
t _{WDAHD}	Write Data Hold vs. WCLK	0.00		0.00		0.00		ns
t _{WADSU}	Write Address Setup vs. WCLK	3.31		3.12		3.67		ns
t _{WADHD}	Write Address Hold vs. WCLK	0.00		0.00		0.00		ns
t _{WENSU}	Write Enable Setup vs. WCLK	3.31		3.12		3.67		ns
t _{WENHD}	Write Enable Hold vs. WCLK	0.00		0.00		0.00		ns
t _{WCKH}	WCLK Minimum High Pulse Width	0.75		0.75		0.75		ns
t _{WCLKL}	WCLK Minimum Low Pulse Width	2.51		2.51		2.51		ns
t _{WCKP}	WCLK Minimum Period	3.26		3.26		3.26		ns
Read Mode								
t _{RADSU}	Read Address Setup vs. RCLK	4.31		4.06		4.77		ns
t _{RADHD}	Read Address Hold vs. RCLK	0.00		0.00		0.00		ns
t _{RENSU}	Read Enable Setup vs. RCLK	4.31		4.06		4.77		ns
t _{RENHD}	Read Enable Hold vs. RCLK	0.00		0.00		0.00		ns
t _{RCK2RD1}	RCLK-To-OUT (Pipelined)		3.30		3.11		3.66	ns
t _{RCK2RD2}	RCLK-To-OUT (Non-Pipelined)		3.96		3.73		4.38	ns
t _{RCLKH}	RCLK Minimum High Pulse Width	2.96		0.73		0.73		ns
t _{RCLKL}	RCLK Minimum Low Pulse Width	3.69		2.96		2.96		ns
t _{RCKP}	RCLK Minimum Period			3.69		3.69		ns

Note: *Timing data for four cascaded RAM blocks uses a depth of 16,384. For all other combinations, use Microsemi's SmartTime tool.

Table 2-106 • Eight RAM Blocks Are Cascaded (Worst-Case Military Conditions VCCA = 1.425 V, VCCI = 3.0 V, T_J = 125°C)

Parameter	Description	Applies to All Speed Grades				Units
		RTAX4000S/SL RTAX4000D/DL		RTAX250/1000/ 2000S/SL RTAX2000D/DL		
		Min.	Max.	Min.	Max.	
Write Mode						
t _{WDASU}	Write Data Setup vs. WCLK	11.80		11.34		ns
t _{WDAHD}	Write Data Hold vs. WCLK	0.00		0.00		ns
t _{WADSU}	Write Address Setup vs. WCLK	11.80		11.34		ns
t _{WADHD}	Write Address Hold vs. WCLK	0.00		0.00		ns
t _{WENSU}	Write Enable Setup vs. WCLK	11.80		11.34		ns
t _{WENHD}	Write Enable Hold vs. WCLK	0.00		0.00		ns
t _{WCKH}	WCLK Minimum High Pulse Width	0.75		0.75		ns
t _{WCLKL}	WCLK Minimum Low Pulse Width	5.13		5.13		ns
t _{WCKP}	WCLK Minimum Period	5.88		5.88		ns
Read Mode						
t _{RADSU}	Read Address Setup vs. RCLK	13.16		12.63		ns
t _{RADHD}	Read Address Hold vs. RCLK	0.00		0.00		ns
t _{RENSU}	Read Enable Setup vs. RCLK	13.16		12.63		ns
t _{RENHD}	Read Enable Hold vs. RCLK	0.00		0.00		ns
t _{RCK2RD1}	RCLK-To-OUT (Pipelined)		8.46		8.19	ns
t _{RCK2RD2}	RCLK-To-OUT (Non-Pipelined)		10.62		10.22	ns
t _{RCLKH}	RCLK Minimum High Pulse Width	0.73		0.73		ns
t _{RCLKL}	RCLK Minimum Low Pulse Width	5.77		5.77		ns
t _{RCKP}	RCLK Minimum Period	6.50		6.50		ns

Note: *Timing data for eight cascaded RAM blocks uses a depth of 32,768. For all other combinations, use Microsemi's SmartTime tool.

Table 2-107 • Sixteen RAM Blocks Are Cascaded (Worst-Case Military Conditions VCCA = 1.425 V, VCCI = 3.0 V, T_J = 125°C)

Parameter	Description	Applies to All Speed Grades				Units
		RTAX4000S/SL RTAX4000D/DL		RTAX250/1000/ 2000S/SL RTAX2000D/DL		
		Min.	Max.	Min.	Max.	
Write Mode						
t _{WDASU}	Write Data Setup vs. WCLK	30.80		29.47		ns
t _{WDAHD}	Write Data Hold vs. WCLK	0.00		0.00		ns
t _{WADSU}	Write Address Setup vs. WCLK	30.80		29.47		ns
t _{WADHD}	Write Address Hold vs. WCLK	0.00		0.00		ns
t _{WENSU}	Write Enable Setup vs. WCLK	30.80		29.47		ns
t _{WENHD}	Write Enable Hold vs. WCLK	0.00		0.00		ns
t _{WCKH}	WCLK Minimum High Pulse Width	0.75		0.75		ns
t _{WCKL}	WCLK Minimum Low Pulse Width	13.40		13.40		ns
t _{WCKP}	WCLK Minimum Period	14.15		14.15		ns
Read Mode						
t _{RASU}	Read Address Setup vs. RCLK	33.01		31.56		ns
t _{RADHD}	Read Address Hold vs. RCLK	0.00		0.00		ns
t _{RENSU}	Read Enable Setup vs. RCLK	33.01		31.56		ns
t _{RENHD}	Read Enable Hold vs. RCLK	0.00		0.00		ns
t _{RCK2RD1}	RCLK-To-OUT (Pipelined)		24.56		23.58	ns
t _{RCK2RD2}	RCLK-To-OUT (Non-Pipelined)		25.61		24.58	ns
t _{RCLKH}	RCLK Minimum High Pulse Width	0.73		0.73		ns
t _{RCKL}	RCLK Minimum Low Pulse Width	14.41		14.41		ns
t _{RCKP}	RCLK Minimum Period	15.14		15.14		ns

Note: Timing data for sixteen cascaded RAM blocks uses a depth of 65,536. For all other combinations, use Microsemi's SmartTime tool.

FIFO

Every memory block has its own embedded FIFO controller. Each FIFO block has one read port and one write port. This embedded FIFO controller uses no internal FPGA logic and features:

- Glitch-free FIFO Flags
- Gray-code address counters/pointers to prevent metastability problems
- Overflow and underflow control

Both ports are configurable in various size from 4kx1 to 128x36, similar to the RAM block size. Each port is fully synchronous.

Read and write operations can be completely independent. Data on the appropriate WD pins are written to the FIFO on every active WCLK edge as long as WEN is high. Data is read from the FIFO and output on the appropriate RD pins on every active RCLK edge as long as REN is asserted.

The FIFO block offers programmable Almost-Empty (AEMPTY) and Almost-Full (AFULL) flags as well as EMPTY and FULL flags ([Figure 2-56](#)):

- The FULL flag is synchronous to WCLK. It allows the FIFO to inhibit writing when full.
- The EMPTY flag is synchronous to RCLK. It allows the FIFO to inhibit reading at the empty condition.

Note: Microsemi recommends that the WCLK and the RCLK are in phase with each other. For more information refer to the application note, [EMPTY and FULL Flag Behaviors of the Axcelerator FIFO Controller](#).

Gray code counters are used to prevent metastability problems associated with flag logic. The depth of the FIFO is dependent on the data width and the number of memory blocks used to create the FIFO. The write operations to the FIFO are synchronous with respect to the WCLK, and the read operations are synchronous with respect to the RCLK.

The FIFO block may be reset to the empty state

The FIFO control unit was not implemented with SEU-hardened registers. Designs requiring high SEU tolerance should implement the FIFO control unit from hardened core logic.

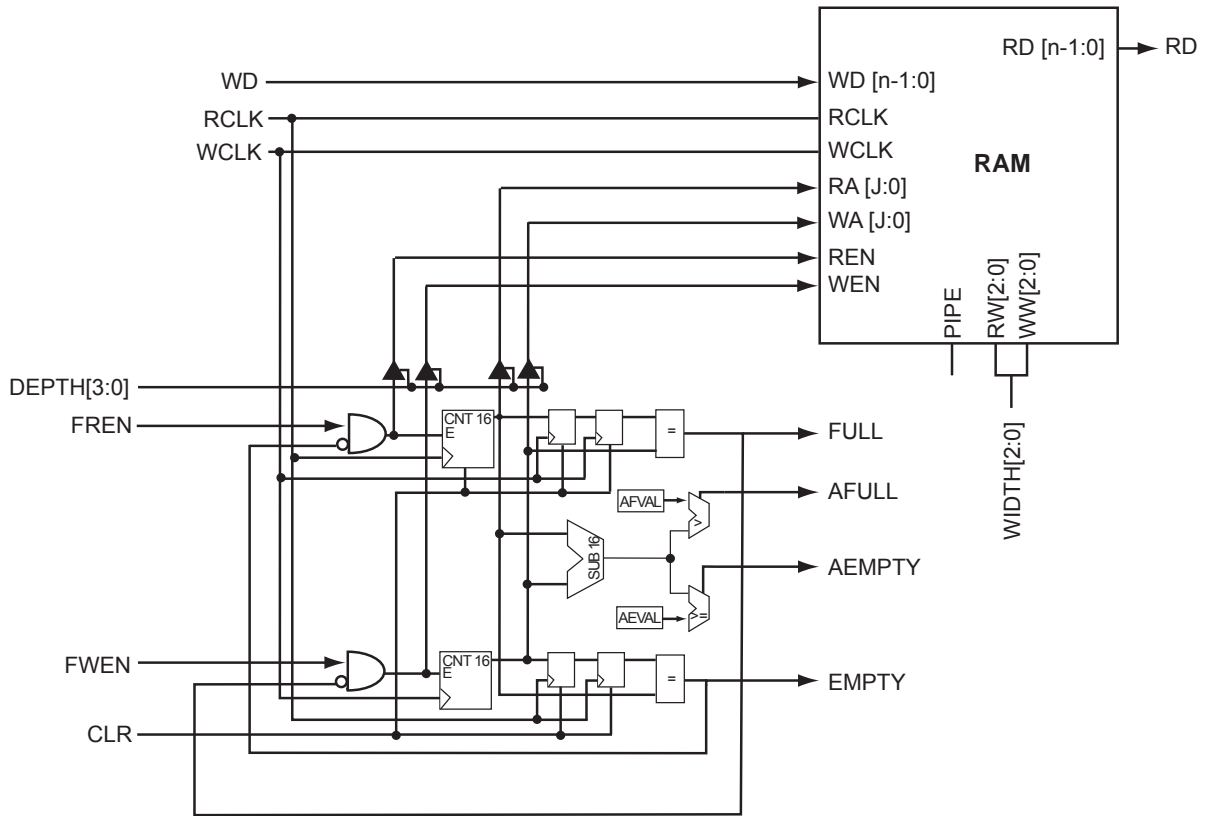

Figure 2-56 • RTAX-S/SL RAM with Embedded FIFO Controller

FIFO Flag Logic

The FIFO is user configurable into various depths and widths. Figure 2-57 shows the FIFO address counter details.

- Bits 11 to 5 are active for all modes.
- As the data word size is reduced, more least-significant bits are added to the address.
- As the number of cascaded blocks increases, the number of significant bits in the address increases.

For example, if four blocks are cascaded as a 1kx16 FIFO with each block having a 1kx4 aspect ratio, bits 11 to 2 of the address will be used to specify locations within each RAM block, whereas bits 13 and 12 will be used to specify the RAM block.

The AFULL and AEMPTY flag threshold values are programmable. The threshold values are AFVAL and AEVAL, respectively. Although the trigger threshold for each flag is defined with eight bits, the effective number of threshold bits in the comparison depends on the configuration. Note that the effective number of threshold bits corresponds to the range of active bits in the FIFO address space (Table 2-108).

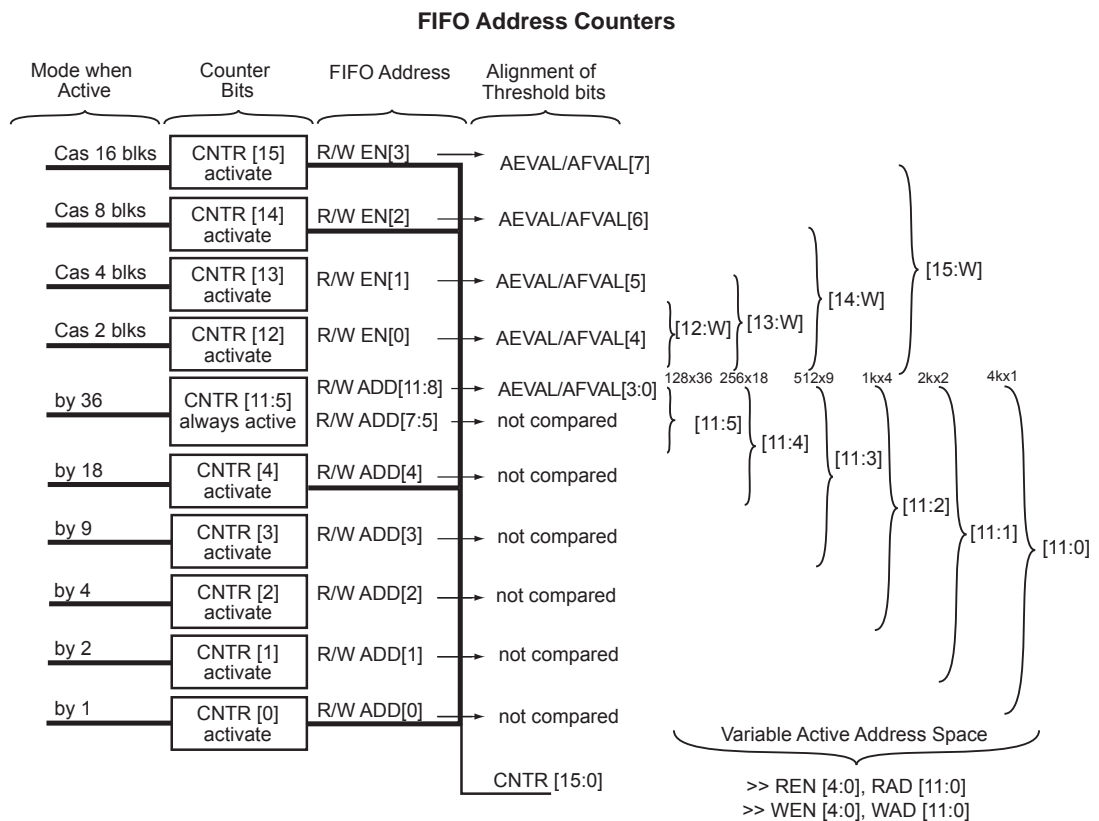

Note: Inactive counter bits are set to zero.

Figure 2-57 • FIFO Address Counters

Table 2-108 • FIFO Flag Logic

Mode	Inactive AEVAL/AFVAL bits	Inactive DIFF bits (set to 0)	DIFF comparison to AFVAL/AEVAL
Non-cascade	[7:4]	[15:12]	DIFF[11:8] with AE/FVAL[3:0]
Cascade 2 blocks	[7:5]	[15:13]	DIFF[12:8] with AE/FVAL[4:0]
Cascade 4 blocks	[7:6]	[15:14]	DIFF[13:8] with AE/FVAL[5:0]
Cascade 8 blocks	[7]	[15]	DIFF[14:8] with AE/FVAL[6:0]
Cascade 16 blocks	None	None	DIFF[15:8] with AE/FVAL[7:0]

Figure 2-58 illustrates flag generation. The Verilog statements for flag assignment are:

```
assign AF = (DIFF[15:0] >={AFVAL[7:0],8'b00000000})?1:0;
```

```
assign AE = ({AEVAL[7:0],8'b00000000}>=DIFF[15:0])?1:0;
```

The number of DIFF-bits active depends on the configuration depth and width (Table 2-109). The active-high CLR pin is used to reset the FIFO to the empty state, which sets FULL and AFULL low, and EMPTY and AEMPTY high.

Assuming that the EMPTY flag is not set, new data is read from the FIFO when REN is valid on the active edge of the clock. Write and read transfers are described with timing requirements in "Timing Characteristics" on page 2-126. For more information refer to the application note, *EMPTY and FULL Flag Behaviors of the Axcelerator FIFO Controller*.

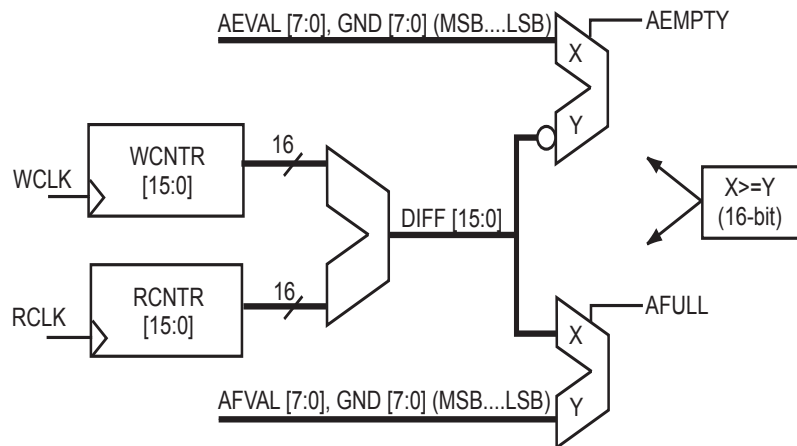

Figure 2-58 • ALMOST-EMPTY and ALMOST-FULL Logic

Table 2-109 • Number of Available Configuration Bits

Number of Blocks	Block DxW	Number of AEVAL/AFVAL Bits
1	1x1	4
2	1x2	4
2	2x1	5
4	1x4	4
4	2x2	5
4	4x1	6
8	1x8	4
8	2x4	5
8	4x2	6
8	8x1	7
16	1x16	4
16	2x8	5
16	4x4	6
16	8x2	7
16	16x1	8

Glitch Elimination

An analog filter is added to each FIFO controller to guarantee, glitch-free FIFO-flag logic.

Overflow and Underflow Control

The counter MSB keeps track of the difference between the read address (RA) and the write address (WA). The EMPTY flag is set when the read and write addresses are equal. To prevent underflow, the write address is double-sampled by the read clock prior to comparison with the read address (part A in Figure 2-59). To prevent overflow, the read address is double-sampled by the write clock prior to comparison to the write address (part B in Figure 2-59).

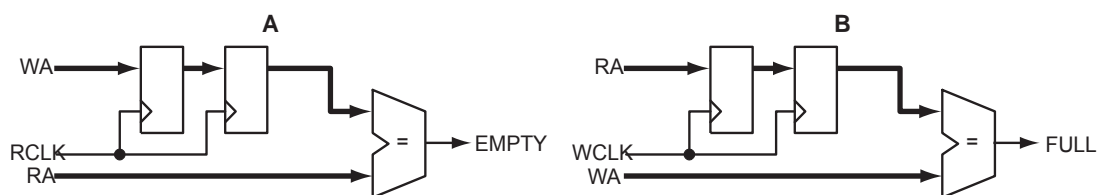

Figure 2-59 • Overflow and Underflow Control

FIFO Configurations

Unlike the RAM, the FIFO's write width and read width cannot be specified independently. For the FIFO, the write and read widths must be the same. The WIDTH pins are used to specify one of six allowable word widths, as shown in Table 2-110.

The DEPTH pins allow RAM cells to be cascaded to create larger FIFOs. The four pins allow depths of 2, 4, 8, and 16 to be specified. Table 2-100 on page 2-112 describes the FIFO depth options for various data width and memory blocks.

Interface

Figure 2-60 shows a logic block diagram of the RTAX-S/SL FIFO module.

Cascading FIFO Blocks

FIFO blocks can be cascaded to create deeper FIFO functions. When building larger FIFO blocks, if the word width can be fractured in a multi-bit FIFO, the fractured word configuration is recommended over a cascaded configuration. For example, 256x36 can be configured as two blocks of 256x18. This should be taken into account when building the FIFO blocks manually. However, when using SmartGen, the user only needs to specify the depth and width of the necessary FIFO blocks. SmartGen automatically configures these blocks to optimize performance.

Clock

As with RAM configuration, the RCLK and WCLK pins have independent polarity selection

Table 2-110 • FIFO Width Configurations

WIDTH(2:0)	WxD
000	1x4k
001	2x2k
010	4x1k
011	9x512
100	18x256
101	36x128
11x	Reserved

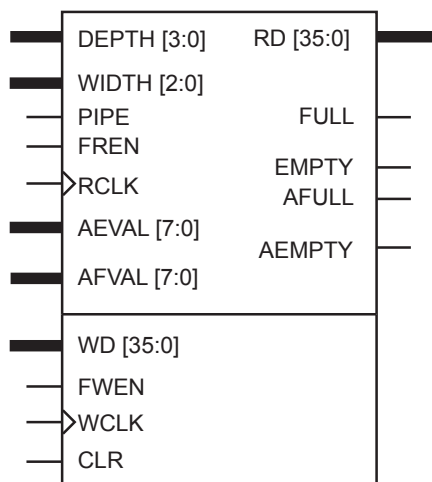

Figure 2-60 • FIFO Block Diagram

Timing Characteristics

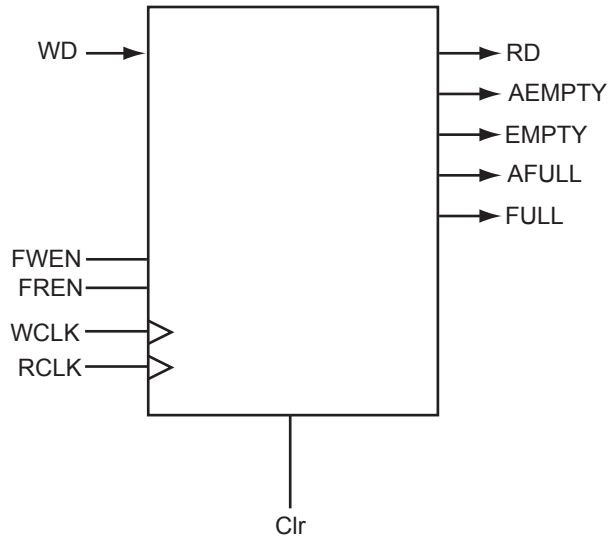

Figure 2-61 • FIFO Model

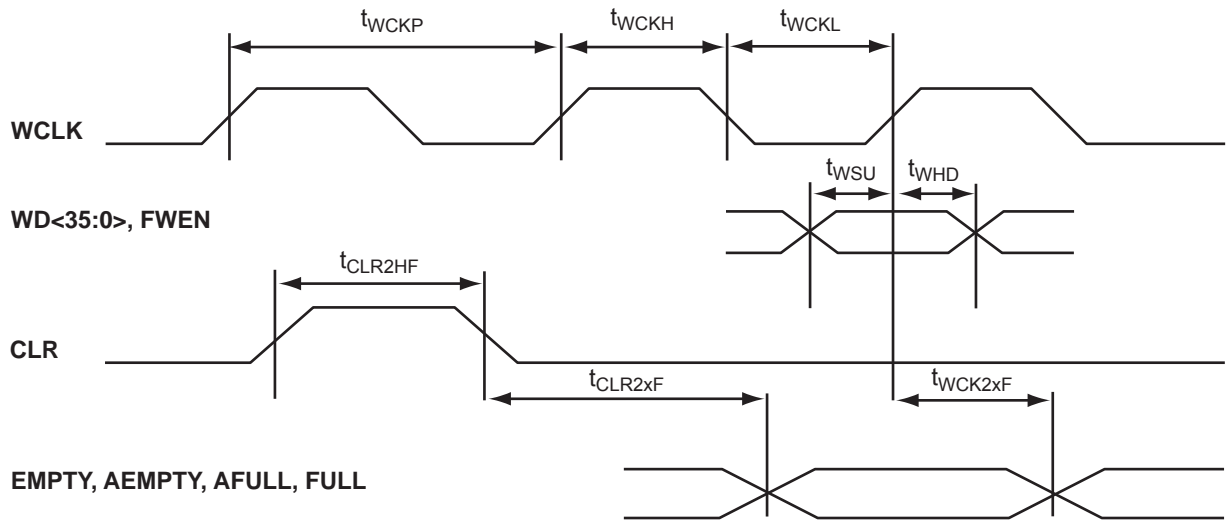

Figure 2-62 • FIFO Write Timing

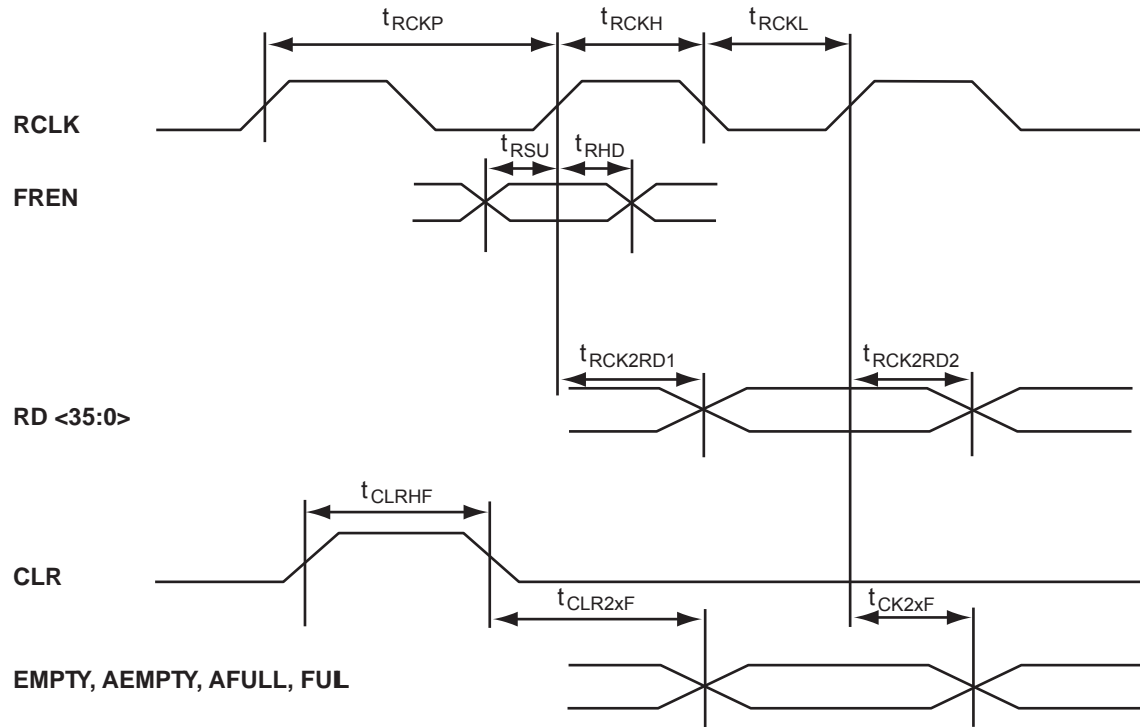

Figure 2-63 • FIFO Read Timing

Table 2-111 • One FIFO Block (Worst-Case Military Conditions VCCA = 1.425 V, VCCI = 3.0 V, T_J = 125°C)

Parameter	Description	-1 Speed				Std. Speed		Units
		RTAX4000S/SL		RTAX250/1000/ 2000S/SL		All		
		Min.	Max.	Min.	Max.	Min.	Max.	
FIFO Module Timing								
t _{WSU}	Write Setup	15.92		15.26		17.64		ns
t _{WHD}	Write Hold	0.31		0.29		0.34		ns
t _{WCKH}	WCLK High	0.75		0.75		0.75		ns
t _{WCKL}	WCLK Low	0.88		0.88		0.88		ns
t _{WCKP}	Minimum WCLK Period	1.63		1.63		1.63		ns
t _{RSU}	Read Setup	16.25		15.32		18.01		ns
t _{RHD}	Read Hold	0.00		0.00		0.00		ns
t _{RCKH}	RCLK High	0.77		0.77		0.77		ns
t _{RCKL}	RCLK Low	0.93		0.93		0.93		ns
t _{RCKP}	Minimum RCLK period	1.70		1.70		1.70		ns
t _{CLR2FF}	Clear-to-flag (EMPTY/FULL)	2.68		2.52		2.97		ns
t _{CLR2AF}	Clear-to-flag (AEMPTY/AFULL)	6.13		5.78		6.79		ns
t _{CK2FF}	Clock-to-flag (EMPTY/FULL)	2.97		2.80		3.29		ns
t _{CK2AF}	Clock-to-flag (AEMPTY/AFULL)	7.05		6.64		7.81		ns
t _{RCK2RD1}	RCLK-To-OUT (Pipelined)		1.85		1.74		2.05	ns
t _{RCK2RD2}	RCLK-To-OUT (Non-Pipelined)		3.02		3.50		4.12	ns

Note: Timing data for this single cascaded FIFO block uses a depth of 4,096. For all other combinations, please use Microsemi's Timing software.

Table 2-112 • Two FIFO Blocks Are Cascaded (Worst-Case Military Conditions VCCA = 1.425 V, VCCI = 3.0 V, T_J = 125°C)

Parameter	Description	-1 Speed				Std. Speed		Units
		RTAX4000S/SL		RTAX250/1000/ 2000S/SL		All		
		Min.	Max.	Min.	Max.	Min.	Max.	
FIFO Module Timing								
t _{WSU}	Write Setup	19.21		18.10		21.28		ns
t _{WHD}	Write Hold	0.00		0.00		0.00		ns
t _{WCKH}	WCLK High	0.75		0.75		0.75		ns
t _{WCKL}	WCLK Low	1.76		1.76		1.76		ns
t _{WCKP}	Minimum WCLK Period	2.51		2.51		2.51		ns
t _{RSU}	Read Setup	20.02		18.86		22.18		ns
t _{RHD}	Read Hold	0.00		0.00		0.00		ns
t _{RCKH}	RCLK High	0.73		0.73		0.73		ns
t _{RCKL}	RCLK Low	1.89		1.89		1.89		ns
t _{RCKP}	Minimum RCLK period	2.62		2.62		2.62		ns
t _{CLR2FF}	Clear-to-flag (EMPTY/FULL)	2.68		2.52		2.97		ns
t _{CLR2AF}	Clear-to-flag (AEMPTY/AFULL)	.6.13		5.78		6.79		ns
t _{CK2FF}	Clock-to-flag (EMPTY/FULL)	2.97		2.80		3.29		ns
t _{CK2AF}	Clock-to-flag (AEMPTY/AFULL)	7.05		6.64		7.81		ns
t _{RCK2RD1}	RCLK-To-OUT (Pipelined)		2.00		1.89		2.22	ns
t _{RCK2RD2}	RCLK-To-OUT (Non-Pipelined)		3.16		2.98		3.50	ns

Note: Timing data for two cascaded FIFO blocks uses a depth of 8,192. For all other combinations, please use Microsemi's Timing software.

Table 2-113 • Four FIFO Blocks Are Cascaded (Worst-Case Military Conditions VCCA = 1.425 V, VCCI = 3.0 V, T_J = 125°C)

Parameter	Description	-1 Speed				Std. Speed		Units
		RTAX4000S/SL		RTAX250/1000/2000S/SL		All		
		Min.	Max.	Min.	Max.	Min.	Max.	
FIFO Module Timing								
t _{WSU}	Write Setup	20.40		19.23		22.60		ns
t _{WHD}	Write Hold	0.00		0.00		0.00		ns
t _{WCKH}	WCLK High	0.75		0.75		0.75		ns
t _{WCKL}	WCLK Low	2.51		2.51		2.51		ns
t _{WCKP}	Minimum WCLK Period	3.26		3.26		3.26		ns
t _{RSU}	Read Setup	21.33		20.10		23.63		ns
t _{RHD}	Read Hold	0.00		0.00		0.00		ns
t _{RCKH}	RCLK High	0.73		0.73		0.73		ns
t _{RCKL}	RCLK Low	2.96		2.96		2.96		ns
t _{RCKP}	Minimum RCLK period	3.69		3.69		3.69		ns
t _{CLR2FF}	Clear-to-flag (EMPTY/FULL)	2.68		2.52		2.97		ns
t _{CLR2AF}	Clear-to-flag (AEMPTY/AFULL)	6.13		5.78		6.79		ns
t _{CK2FF}	Clock-to-flag (EMPTY/FULL)	2.97		2.80		3.29		ns
t _{CK2AF}	Clock-to-flag (AEMPTY/AFULL)	7.05		6.64		7.81		ns
t _{RCK2RD1}	RCLK-To-OUT (Pipelined)		3.30		3.11		3.66	ns
t _{RCK2RD2}	RCLK-To-OUT (Non-Pipelined)		3.96		3.73		4.38	ns

Note: Timing data for four cascaded FIFO blocks uses a depth of 16,384. For all other combinations, please use Microsemi's Timing software.

Table 2-114 • Eight FIFO Blocks Are Cascaded (Worst-Case Military Conditions VCCA = 1.425 V, VCCI = 3.0 V, T_J = 125°C)

Parameter	Description	-1 Speed				Std. Speed		Units
		RTAX4000S/SL		RTAX250/1000/ 2000S/SL		All		
		Min.	Max.	Min.	Max.	Min.	Max.	
FIFO Module Timing								
t _{WSU}	Write Setup	21.59		20.35		23.92		ns
t _{WHD}	Write Hold	0.00		0.00		0.00		ns
t _{WCKH}	WCLK High	0.75		0.75		0.75		ns
t _{WCKL}	WCLK Low	5.13		5.13		5.13		ns
t _{WCKP}	Minimum WCLK Period	5.88		5.88		5.88		ns
t _{RSU}	Read Setup	22.66		21.35		25.10		ns
t _{RHD}	Read Hold	0.00		0.00		0.00		ns
t _{RCKH}	RCLK High	0.73		0.73		0.73		ns
t _{RCKL}	RCLK Low	5.77		5.77		5.77		ns
t _{RCKP}	Minimum RCLK period	6.50		6.50		6.50		ns
t _{CLR2FF}	Clear-to-flag (EMPTY/FULL)	2.68		2.52		2.97		ns
t _{CLR2AF}	Clear-to-flag (AEMPTY/AFULL)	6.13		5.78		6.79		ns
t _{CK2FF}	Clock-to-flag (EMPTY/FULL)	2.97		2.80		3.29		ns
t _{CK2AF}	Clock-to-flag (AEMPTY/AFULL)	7.05		6.64		7.81		ns
t _{RCK2RD1}	RCLK-To-OUT (Pipelined)		4.73		4.46		5.24	ns
t _{RCK2RD2}	RCLK-To-OUT (Non-Pipelined)		6.89		6.49		7.63	ns

Note: Timing data for eight cascaded FIFO blocks uses a depth of 32,768. For all other combinations, please use Microsemi's Timing software.

Table 2-115 • Sixteen FIFO Blocks are Cascaded (Worst-Case Military Conditions VCCA = 1.425 V, VCCI = 3.0 V, T_J = 125°C)

Parameter	Description	-1 Speed				Std. Speed		Units
		RTAX4000S/SL		RTAX250/1000/2000S/SL		All		
		Min.	Max.	Min.	Max.	Min.	Max.	
FIFO Module Timing								
t _{WSU}	Write Setup	22.80		21.49		25.27		ns
t _{WHD}	Write Hold	0.00		0.00		0.00		ns
t _{WCKH}	WCLK High	0.75		0.75		0.75		ns
t _{WCKL}	WCLK Low	13.40		13.40		13.40		ns
t _{WCKP}	Minimum WCLK Period	14.15		14.15		14.15		ns
t _{RSU}	Read Setup	23.97		22.59		26.55		ns
t _{RHD}	Read Hold	0.00		0.00		0.00		ns
t _{RCKH}	RCLK High	0.73		0.73		0.73		ns
t _{RCKL}	RCLK Low	14.41		14.41		14.41		ns
t _{RCKP}	Minimum RCLK period	15.14		15.14		15.14		ns
t _{CLR2FF}	Clear-to-flag (EMPTY/FULL)	2.68		2.52		2.97		ns
t _{CLR2AF}	Clear-to-flag (AEMPTY/AFULL)	6.13		5.78		6.79		ns
t _{CK2FF}	Clock-to-flag (EMPTY/FULL)	2.97		2.80		3.29		ns
t _{CK2AF}	Clock-to-flag (AEMPTY/AFULL)	7.05		6.64		7.81		ns
t _{RCK2RD1}	RCLK-To-OUT (Pipelined)		16.87		15.90		18.69	ns
t _{RCK2RD2}	RCLK-To-OUT (Non-Pipelined)		17.93		16.90		19.86	ns

Note: Timing data for sixteen cascaded FIFO blocks uses a depth of 65,536. For all other combinations, please use Microsemi's Timing software.

Building RAM and FIFO Modules

RAM and FIFO modules can be generated and included in a design in two different ways:

- Using the SmartGen core generator where the user defines the depth and width of the FIFO/RAM, and then instantiates this block into the design (please refer to the [SmartGen](#), [FlashROM](#), [Analog System Builder](#), and [Flash Memory System Builder User's Guide](#) for more information).
- The alternative is to instantiate the RAM/FIFO blocks manually, using inverters for polarity control and tying all unused data bits to ground.

Other Architectural Features

Charge Pump Bypass

To reduce power consumption, the internal charge pump can be bypassed and an external power supply voltage can be used instead. This saves the internal charge-pump operating current, resulting in no DC current draw. The RTAX-S/SL family devices have a dedicated "V_{PUMP}" pin that can be used to access an external charge pump device. In normal chip operation, when using the internal charge pump, V_{PUMP} should be tied to GND. When the voltage level on V_{PUMP} is set to 3.3 V, the internal charge pump is turned off, and the V_{PUMP} voltage will be used as the charge pump voltage. Adequate voltage regulation (i.e., high drive, low output impedance, and good decoupling) should be used at V_{PUMP}.

JTAG

RTAX-S/SL offers a JTAG interface that is compliant with the IEEE 1149.1 standard except for the device ID length which is 33 bits. The user can employ the JTAG interface for probing a design and executing any JTAG public instructions as defined in the [Table 2-116](#). The JTAG pins and probes are configured as a LVTTTL standard port. Refer to the [IEEE Standard 1149.1 \(JTAG\) in the Axcelerator Family](#) application note, which also applies to the RTAX-S/SL family of devices. **The JTAG pins should not be left floating on flight systems.**

Table 2-116 • JTAG Instruction Code

Instruction (IR4:IR0)	Binary Code
EXTEST	00000
PRELOAD / SAMPLE	00001
INTEST	00010
USERCODE	00011
IDCODE	00100
HIGHZ	01110
CLAMP	01111
DIAGNOSTIC	10000
Reserved	All others
BYPASS	11111

Interface

The interface consists of four inputs: Test Mode Select (TMS), Test Data In (TDI), Test Clock (TCK), TAP Controller Reset (TRST), and an output, Test Data Out (TDO). TMS, TDI, and TRST have on-chip pull-up resistors.

TRST

The TRST pin functions as an active-low input to asynchronously initialize or reset the boundary scan circuit. The TRST pin is equipped with a programmable pull-up resistor with approximately 10 kΩ resistance. This pin must be hardwired to ground for flight.

TDO

TDO is normally tristated, and it is active only when the TAP controller is in the "Shift_DR" state or "Shift_IR" state. The least significant bit of the selected register (i.e., IR or DR) is clocked out to TDO first by the falling edge of TCK.

TAP Controller

The TAP Controller is compliant with the IEEE Standard 1149.1. It is a state machine of 16 states that controls the Instruction Register (IR) and the Data Registers (such as Boundary-Scan Register, IDCODE, USRCODE, BYPASS, etc.). The TAP Controller steps into one of the states depending on the sequence of TMS at the rising edges of TCK.

Instruction Register (IR)

The IR has five bits (IR4 to IR0). At the TRST state, IR is reset to IDCODE. Each time when IR is selected, it goes through "select IR-Scan," "Capture-IR," "Shift-IR," all the way through "Update-IR." When there is no test error, the first five data bits coming out of TDO during the "Shift-IR" will be "10111." If a test error occurs, the last three bits will contain one to three zeroes corresponding to negatively asserted signals: "TDO_ERRORB," "PROBA_ERRORB," and "PROBB_ERRORB." The error(s) will be erased when the TAP is at the "Update-IR" or the TRST state. When in user mode start-up sequence, if the micro-probe has not been used, the "PROBA_ERRORB" is used as a "Power-up done successfully" flag.

During flight, the following configurations for all JTAG and Probe pins are recommended ([Table 2-117 on page 2-134](#)).

Table 2-117 • JTAG and Probe Pin Recommendations for Flight

JTAG and Probe Pins	Configurations
TCK	<ul style="list-style-type: none"> • Can be hardwired to VCCDA or ground • Can be driven to VCCDA or ground • Must not be left unterminated
TDO	Must be left unconnected
TDI	<ul style="list-style-type: none"> • Can be hardwired or driven to VCCDA • Can be left unconnected (equipped with internal 10 k pull-up resistor)
TMS	<ul style="list-style-type: none"> • Can be hardwired or driven to VCCDA • Can be left unconnected (equipped with internal 10 k pull-up resistor)
TRST	Must be hardwired to ground (equipped with optional internal 10 k pull-up resistor)
PRA/B/C/D	May be left unconnected, or may be connected via pull-up or pull-down resistor to VCCI or GND. PRA/B/C/D are in tristate mode during normal operation. In test mode, these pins put out the logic value of the internal node they are connected to.

Data Registers (DRs)

Data registers are distributed throughout the chip. They store testing/programming vectors. The MSB of a data register is connected to TDI, while the LSB is connected to TDO. There are different types of data registers. Descriptions of the main registers are as follow:

1. IDCODE:

The IDCODE is a hard coded JTAG Silicon Signature. It is a hardwired device ID code, which contains the Microsemi identity, part number, and version number in a specific JTAG format. Refer to the *IEEE Standard 1149.1 (JTAG) in the Axcelerator Family* application note for more information. The IDCODE is 33 bits in length in the following devices: RTAX250S/SL, RTAX1000S/SL, and RTAX2000S/SL. The IDCODE is 32 bits in length in the following devices: RTAX2000D, RTAX4000S/SL, and RTAX4000D.

2. USERCODE:

The USERCODE is a programmable JTAG register. It is a supplementary identity code for the user to program information to distinguish different programmed parts. USERCODE fuses will read out as "zeroes" when not programmed, so only the "1" bits need to be programmed. Refer to the *IEEE Standard 1149.1 (JTAG) in the Axcelerator Family* application note for more information. The USERCODE physical register length is 33 bits in RTAX250S/SL, RTAX1000S/SL, and RTAX2000S/SL devices, but is 32 bits in RTAX2000D, RTAX4000S/SL, and RTAX4000D devices. Only 20 bits are allocated to the user. The rest of the bits are reserved.

3. Boundary-Scan Register (BSR):

Each I/O contains three BSR Cells. Each cell has a shift register bit, a latch, and two MUXes. The boundary-scan cells are used for the Output-enable (E), Output (O), and Input (I) registers. The bit order of the boundary-scan cells for each of them is E-O-I. The boundary-scan cells are then chained serially to form the BSR. The length of the BSR is the number of I/Os in the die (not the package) multiplied by three. This excludes special function pins (TRST, TCK, TMS, TDI, TDO, PRA, PRB, PRC, PRD, and VPUMP).

4. Bypass Register (BYR):

This is the "1-bit" register. It is used to shorten the TDI-TDO serial chain in board-level testing to only one bit per device not being tested. It is also selected for all "reserved" or unused instructions.

Probing

Internal activities of the JTAG interface can be observed via the Silicon Explorer II probes: "PRA," "PRB," "PRC," and "PRD."

Special Fuses

Security

Microsemi antifuse FPGAs, with FuseLock technology, offer the highest level of design security available in a programmable logic device. Since antifuse FPGAs are live at power-up, there is no bitstream that can be intercepted, and no bitstream or programming data is ever downloaded to the device during power-up, thus making device cloning impossible. In addition, special security fuses are hidden throughout the fabric of the device and may be programmed by the user to thwart attempts to reverse engineer the device by attempting to exploit either the programming or probing interfaces. Both invasive and noninvasive attacks against an RTAX-S/SL device that access or bypass these security fuses will destroy access to the rest of the device (refer to the [Design Security in Nonvolatile Flash and Antifuse FPGAs](#) white paper).

Look for this symbol to ensure your valuable IP is protected by the highest level of security in the industry.



Figure 2-64 • FuseLock Logo

To ensure maximum security in RTAX-S/SL devices, it is recommended that the user program the device security fuse (SFUS). When programmed, the Silicon Explorer II testing probes are disabled to prevent internal probing, and the programming interface is also disabled. All JTAG public instructions are still accessible by the user.

For more information, refer to the [Implementation of Security in Actel Antifuse FPGAs](#) application note.

Global Set Fuse

During device power-up, the Global Set Fuse option determines if all R-cells and I/O registers (InReg, OutReg, and EnReg) are either cleared (outputs set to 0) or preset (outputs set to 1) by driving the internal GCLR and GPSET input pins of all R-cells and I/O registers. Users do not have access to the GCLR and GPSET pins. The default Global Set Fuse option in software is cleared during programming file generation and will clear all registers. When this option is selected, all registers are preset.

Once the device completes power-up, the user CLR or PRESET inputs will take precedence over the Global Set Fuse. Both GCLR and GPSET pins are deactivated during normal device operation. An application note will be published to provide details on the Global Set Fuse operation. Until then, refer to the following Space Forum presentation for more information:

www.microsemi.com/document-portal/doc_download/125249-dig-f-rtax-s-sl-dsp-power-on-reset-operation-b-youssef-final

Silicon Explorer II Probe Interface

Silicon Explorer II is an integrated hardware and software solution that, in conjunction with the Designer tools, allows users to examine any of the internal nets (except I/O registers) of the device while it is operating in a prototype or a production system. The user can probe up to four nodes at a time without changing the placement and routing of the design and without using any additional device resources. Highlighted nets in Designer's ChipPlanner can be accessed using Silicon Explorer II in order to observe their real time values.

Silicon Explorer II's noninvasive method does not alter timing or loading effects, thus shortening the debug cycle. In addition, Silicon Explorer II does not require relayout or additional MUXes to bring signals out to an external pin, which is necessary when using programmable logic devices from other suppliers. By eliminating multiple place-and-route program cycles the integrity of the design is maintained throughout the debug process.

Each member of the RTAX-S/SL family has four external pads: PRA, PRB, PRC, and PRD. These can be used to bring out four probe signals from the RTAX-S/SL device. Each core tile can has up to two probe

signals. To disallow probing, the SFUS security fuse in the silicon signature has to be programmed (see "Special Fuses" on page 2-136 for more information).

Silicon Explorer II connects to the host PC using a standard serial port connector. Connections to the circuit board are achieved using a nine-pin D-Sub connector (Figure 1-15 on page 1-13). Once the design has been placed-and-routed, and the RTAX-S/SL device has been programmed, Silicon Explorer II can be connected and the Explorer software can be launched.

Silicon Explorer II comes with an additional optional PC hosted tool that emulates an 18-channel logic analyzer. Four channels are used to monitor four internal nodes, and 14 channels are available to probe external signals. The software included with the tool provides the user with an intuitive interface that allows for easy viewing and editing of signal waveforms.

Programming

Device programming is supported through the Silicon Sculptor 3, a single-site, robust and compact device programmer for the PC. Up to four Silicon Sculptor 3s can be daisy-chained and controlled from a single PC host. With standalone software for the PC, Silicon Sculptor 3 is designed to allow concurrent programming of multiple units from the same PC when daisy-chained.

Silicon Sculptor 3 programs devices independently to achieve the fastest programming times possible. Each fuse is verified by Silicon Sculptor 3 to ensure correct programming. Furthermore, at the end of programming, there are integrity tests that are run to ensure that programming was completed properly. Not only does it test programmed and nonprogrammed fuses, Silicon Sculptor 3 also provides a self-test to test its own hardware extensively.

Programming an RTAX-S/SL device using Silicon Sculptor 3 is similar to programming any other antifuse device. The procedure is as follows:

1. Load the AFM file.
2. Select the device to be programmed.
3. Begin programming.

When the design is ready to go to production, Microsemi offers device volume-programming services either through distribution partners or via our In-House Programming Center.

For more details on programming the RTAX-S/SL devices, please refer to the [Silicon Sculptor User's Guide](#).

Table 2-118 • FIFO Signal Description

Signal	Direction	Description
WCLK	Input	Write clock (active either edge).
FWEN	Input	FIFO write enable. When this signal is asserted, the WD bus data is latched into the FIFO, and the internal write counters are incremented.
WD[N-1:0]	Input	Write data bus. The value N is dependent on the RAM configuration and can be 1, 2, 4, 9, 18, or 36.
FULL	Output	Active high signal indicating that the FIFO is FULL. When this signal is set, additional write requests are ignored.
AFULL	Output	Active high signal indicating that the FIFO is AFULL.
AFVAL	Input	8-bit input defining the AFULL value of the FIFO.
RCLK	Input	Read clock (active either edge).
FREN	Input	FIFO read enable.
RD[N-1:0]	Output	Read data bus. The value N is dependent on the RAM configuration and can be 1, 2, 4, 9, 18, or 36.
EMPTY	Output	Empty flag indicating that the FIFO is EMPTY. When this signal is asserted, attempts to read the FIFO will be ignored.
AEMPTY	Output	Active high signal indicating that the FIFO is AEMPTY.
AEVAL	Input	8-bit input defining the almost-empty value of the FIFO.
PIPE	Input	Sets the pipe option on or off.
CLR	Input	Active high clear input.
DEPTH	Input	Determines the depth of the FIFO and the number of FIFOs to be cascaded.
WIDTH	Input	Determines the width of the dataword / width of the FIFO, and the number of the FIFOs to be cascaded.

3 – Package Pin Assignments

CQ208

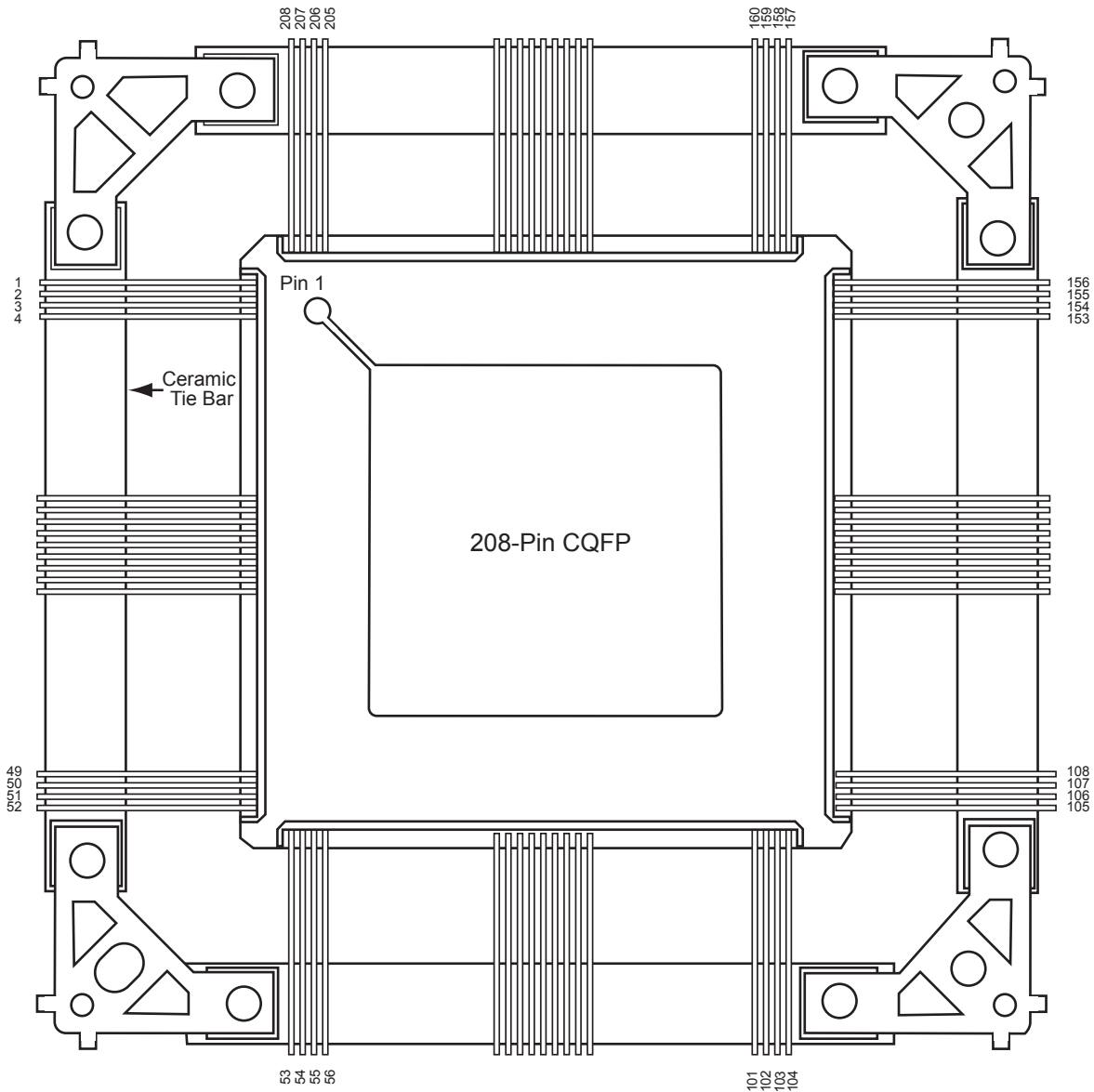

Note

For Package Manufacturing and Environmental information, visit the Resource center at <http://www.microsemi.com/soc/products/solutions/package/docs.aspx>.

CQ208	
RTAX250S/SL Function	Pin Number
Bank 0	
IO02NB0F0	197
IO03NB0F0	198
IO03PB0F0	199
IO12NB0F0/HCLKAN	191
IO12PB0F0/HCLKAP	192
IO13NB0F0/HCLKBN	185
IO13PB0F0/HCLKBP	186
Bank 1	
IO14NB1F1/HCLKCN	180
IO14PB1F1/HCLKCP	181
IO15NB1F1/HCLKDN	174
IO15PB1F1/HCLKDP	175
IO16NB1F1	170
IO16PB1F1	171
IO24NB1F1	165
IO24PB1F1	166
IO26NB1F1	161
IO26PB1F1	162
IO27NB1F1	159
IO27PB1F1	160
Bank 2	
IO29NB2F2	151
IO29PB2F2	153
IO30NB2F2	152
IO30PB2F2	154
IO31PB2F2	148
IO32NB2F2	146
IO32PB2F2	147
IO34NB2F2	144
IO34PB2F2	145
IO39NB2F2	139
IO39PB2F2	140
IO40PB2F2	141
IO41NB2F2	137
IO41PB2F2	138
IO43NB2F2	132

CQ208	
RTAX250S/SL Function	Pin Number
IO43PB2F2	134
IO44NB2F2	131
IO44PB2F2	133
Bank 3	
IO45NB3F3	127
IO45PB3F3	129
IO46NB3F3	126
IO46PB3F3	128
IO48NB3F3	122
IO48PB3F3	123
IO50NB3F3	120
IO50PB3F3	121
IO55NB3F3	116
IO55PB3F3	117
IO57NB3F3	114
IO57PB3F3	115
IO59NB3F3	110
IO59PB3F3	111
IO60NB3F3	108
IO60PB3F3	109
IO61NB3F3	106
IO61PB3F3	107
Bank 4	
IO62NB4F4	100
IO62PB4F4	103
IO63NB4F4	101
IO63PB4F4	102
IO64NB4F4	96
IO64PB4F4	97
IO72NB4F4	91
IO72PB4F4	92
IO74NB4F4/CLKEN	87
IO74PB4F4/CLKEP	88
IO75NB4F4/CLKFN	81
IO75PB4F4/CLKFP	82
Bank 5	
IO76NB5F5/CLKGN	76

CQ208	
RTAX250S/SL Function	Pin Number
IO76PB5F5/CLKGP	77
IO77NB5F5/CLKHN	70
IO77PB5F5/CLKHP	71
IO78NB5F5	66
IO78PB5F5	67
IO86NB5F5	62
IO87NB5F5	60
IO87PB5F5	61
IO88NB5F5	56
IO88PB5F5	57
IO89NB5F5	54
IO89PB5F5	55
Bank 6	
IO91NB6F6	47
IO91PB6F6	49
IO92NB6F6	48
IO92PB6F6	50
IO93NB6F6	42
IO93PB6F6	43
IO94PB6F6	44
IO96NB6F6	40
IO96PB6F6	41
IO101NB6F6	35
IO101PB6F6	36
IO102PB6F6	37
IO103NB6F6	33
IO103PB6F6	34
IO105NB6F6	28
IO105PB6F6	30
IO106NB6F6	27
IO106PB6F6	29
Bank 7	
IO107NB7F7	23
IO107PB7F7	25
IO108NB7F7	22
IO108PB7F7	24
IO110NB7F7	18

CQ208		CQ208		CQ208	
RTAX250S/SL Function	Pin Number	RTAX250S/SL Function	Pin Number	RTAX250S/SL Function	Pin Number
IO110PB7F7	19	GND	194	VCCA	156
IO112NB7F7	16	GND	196	VCCA	168
IO112PB7F7	17	GND	201	VCCA	195
IO117NB7F7	12	GND	208	VCCDA	1
IO117PB7F7	13	NC	72	VCCDA	26
IO119NB7F7	10	NC	73	VCCDA	53
IO119PB7F7	11	NC	74	VCCDA	63
IO121PB7F7	7	NC	75	VCCDA	78
IO122NB7F7	5	NC	83	VCCDA	95
IO122PB7F7	6	NC	84	VCCDA	105
IO123NB7F7	3	NC	85	VCCDA	130
IO123PB7F7	4	NC	86	VCCDA	157
Dedicated I/O		NC	176	VCCDA	167
GND	9	NC	177	VCCDA	182
GND	15	NC	178	VCCDA	202
GND	21	NC	179	VCCIB0	193
GND	32	NC	187	VCCIB0	200
GND	39	NC	188	VCCIB1	163
GND	46	NC	189	VCCIB1	172
GND	51	NC	190	VCCIB2	135
GND	59	PRA	184	VCCIB2	149
GND	65	PRB	183	VCCIB3	112
GND	69	PRC	80	VCCIB3	124
GND	90	PRD	79	VCCIB4	89
GND	94	PRD	79	VCCIB4	98
GND	99	TCK	205	VCCIB5	58
GND	104	TDI	204	VCCIB5	68
GND	113	TDO	203	VCCIB6	31
GND	119	TMS	206	VCCIB6	45
GND	125	TRST	207	VCCIB7	8
GND	136	VCCA	2	VCCIB7	20
GND	143	VCCA	14	VPUMP	158
GND	143	VCCA	38		
GND	150	VCCA	52		
GND	155	VCCA	64		
GND	164	VCCA	93		
GND	169	VCCA	118		
GND	173	VCCA	142		

CQ256

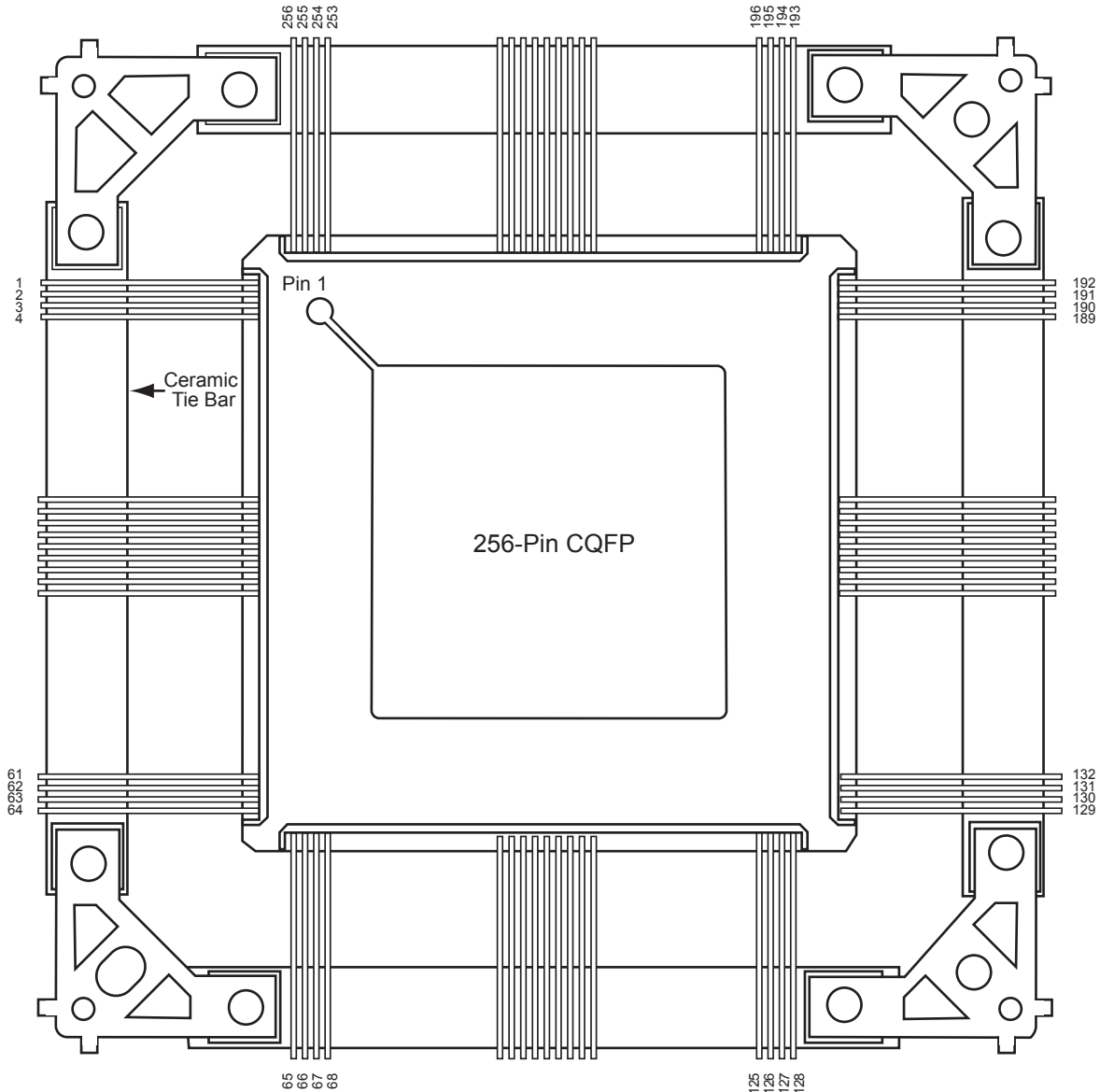

Note

For Package Manufacturing and Environmental information, visit the Resource center at <http://www.microsemi.com/soc/products/solutions/package/docs.aspx>.

CQ256		CQ256		CQ256	
RTAX2000S/SL Function	Pin Number	RTAX2000S/SL Function	Pin Number	RTAX2000S/SL Function	Pin Number
Bank 0		Bank 2		Bank 4	
IO01NB0F0	248	IO107NB2F10	184	IO167PB3F15	134
IO01PB0F0	249	IO107PB2F10	185	Bank 4	
IO04NB0F0	246	IO110NB2F10	180	IO181NB4F17	124
IO04PB0F0	247	IO110PB2F10	181	IO181PB4F17	125
IO05NB0F0	242	IO111NB2F10	178	IO182NB4F17	122
IO05PB0F0	243	IO111PB2F10	179	IO182PB4F17	123
IO08NB0F0	240	IO112NB2F10	174	IO183NB4F17	118
IO08PB0F0	241	IO112PB2F10	175	IO183PB4F17	119
Bank 0		IO113NB2F10	172	IO184NB4F17	116
IO37NB0F3	234	IO113PB2F10	173	IO184PB4F17	117
IO37PB0F3	235	IO114NB2F10	168	IO190NB4F17	112
IO41NB0F3/HCLKAN	232	IO114PB2F10	169	IO190PB4F17	113
IO41PB0F3/HCLKAP	233	IO115NB2F10	166	IO192NB4F17	110
IO42NB0F3/HCLKBN	228	IO115PB2F10	167	IO192PB4F17	111
IO42PB0F3/HCLKBP	229	IO117NB2F10	162	Bank 4	
Bank 1 -		IO117PB2F10	163	IO212NB4F19/CLKEN	104
IO43NB1F4/HCLKCN	220	Bank 3		IO212PB4F19/CLKKP	105
IO43PB1F4/HCLKCP	221	IO139NB3F13	158	IO213NB4F19/CLKFN	100
IO44NB1F4/HCLKDN	216	IO139PB3F13	159	IO213PB4F19/CLKFP	101
IO44PB1F4/HCLKDP	217	IO141NB3F13	154	Bank 5	
Bank 1		IO141PB3F13	155	IO214NB5F20/CLKGN	92
IO65NB1F6	210	IO142NB3F13	152	IO214PB5F20/CLKGP	93
IO65PB1F6	211	IO142PB3F13	153	IO215NB5F20/CLKHN	88
IO69NB1F6	208	IO145NB3F13	148	IO215PB5F20/CLKHP	89
IO69PB1F6	209	IO145PB3F13	149	Bank 5	
IO70NB1F6	199	IO146NB3F13	146	IO236NB5F22	82
IO71NB1F6	204	IO146PB3F13	147	IO236PB5F22	83
IO71PB1F6	205	IO147NB3F13	140	IO238NB5F22	80
IO73NB1F6	202	IO147PB3F13	141	IO238PB5F22	81
IO73PB1F6	203	IO148NB3F13	142	IO240NB5F22	76
IO74NB1F6	197	IO148PB3F13	143	IO240PB5F22	77
IO74PB1F6	198	IO149NB3F13	136	IO242NB5F22	74
Bank 2		IO149PB3F13	137	IO242PB5F22	75
IO87NB2F8	187	Bank 3		IO243NB5F22	70
IO87PB2F8	188	IO165NB3F15	135	IO243PB5F22	71
IO89PB2F8	186	IO167NB3F15	133	IO244NB5F22	68
				IO244PB5F22	69

CQ256	
RTAX2000S/SL Function	Pin Number
Bank 6	
IO257PB6F24	60
IO258NB6F24	58
IO258PB6F24	59
Bank 6	
IO279NB6F26	56
IO279PB6F26	57
IO280NB6F26	52
IO280PB6F26	53
IO281NB6F26	50
IO281PB6F26	51
IO282NB6F26	46
IO282PB6F26	47
IO284NB6F26	44
IO284PB6F26	45
IO285NB6F26	40
IO285PB6F26	41
IO286NB6F26	38
IO286PB6F26	39
IO287NB6F26	34
IO287PB6F26	35
Bank 7 9	
IO310NB7F29	30
IO310PB7F29	31
IO311NB7F29	26
IO311PB7F29	27
IO312NB7F29	24
IO312PB7F29	25
IO315NB7F29	20
IO315PB7F29	21
IO316NB7F29	18
IO316PB7F29	19
IO317NB7F29	14
IO317PB7F29	15
IO318NB7F29	12
IO318PB7F29	13
IO320NB7F29	8

CQ256	
RTAX2000S/SL Function	Pin Number
IO320PB7F29	9
Bank 7	
IO341NB7F31	6
IO341PB7F31	7
Dedicated I/O	
GND	1
GND	5
GND	11
GND	17
GND	23
GND	29
GND	33
GND	37
GND	43
GND	49
GND	55
GND	62
GND	64
GND	65
GND	73
GND	79
GND	85
GND	91
GND	97
GND	103
GND	109
GND	115
GND	121
GND	128
GND	129
GND	132
GND	139
GND	145
GND	151
GND	157
GND	161
GND	165

CQ256	
RTAX2000S/SL Function	Pin Number
GND	171
GND	177
GND	183
GND	190
GND	192
GND	193
GND	201
GND	207
GND	213
GND	219
GND	225
GND	231
GND	239
GND	245
GND	256
PRA	227
PRB	226
PRC	99
PRD	98
TCK	253
TDI	252
TDO	250
TMS	254
TRST	255
VCCA	3
VCCA	4
VCCA	22
VCCA	42
VCCA	61
VCCA	63
VCCA	84
VCCA	108
VCCA	127
VCCA	131
VCCA	150
VCCA	170
VCCA	189

CQ256	
RTAX2000S/SL Function	Pin Number
VCCA	191
VCCA	212
VCCA	238
VCCDA	2
VCCDA	32
VCCDA	66
VCCDA	67
VCCDA	86
VCCDA	87
VCCDA	94
VCCDA	95
VCCDA	96
VCCDA	106
VCCDA	107
VCCDA	126
VCCDA	130
VCCDA	160
VCCDA	194
VCCDA	196
VCCDA	214
VCCDA	215
VCCDA	222
VCCDA	223
VCCDA	224
VCCDA	236
VCCDA	237
VCCDA	251
VCCIB0	230
VCCIB0	244
VCCIB1	200
VCCIB1	206
VCCIB1	218
VCCIB2	164
VCCIB2	176
VCCIB2	182
VCCIB3	138
VCCIB3	144

CQ256	
RTAX2000S/SL Function	Pin Number
VCCIB3	156
VCCIB4	102
VCCIB4	114
VCCIB4	120
VCCIB5	72
VCCIB5	78
VCCIB5	90
VCCIB6	36
VCCIB6	48
VCCIB6	54
VCCIB7	10
VCCIB7	16
VCCIB7	28
VPUMP	195

CQ352

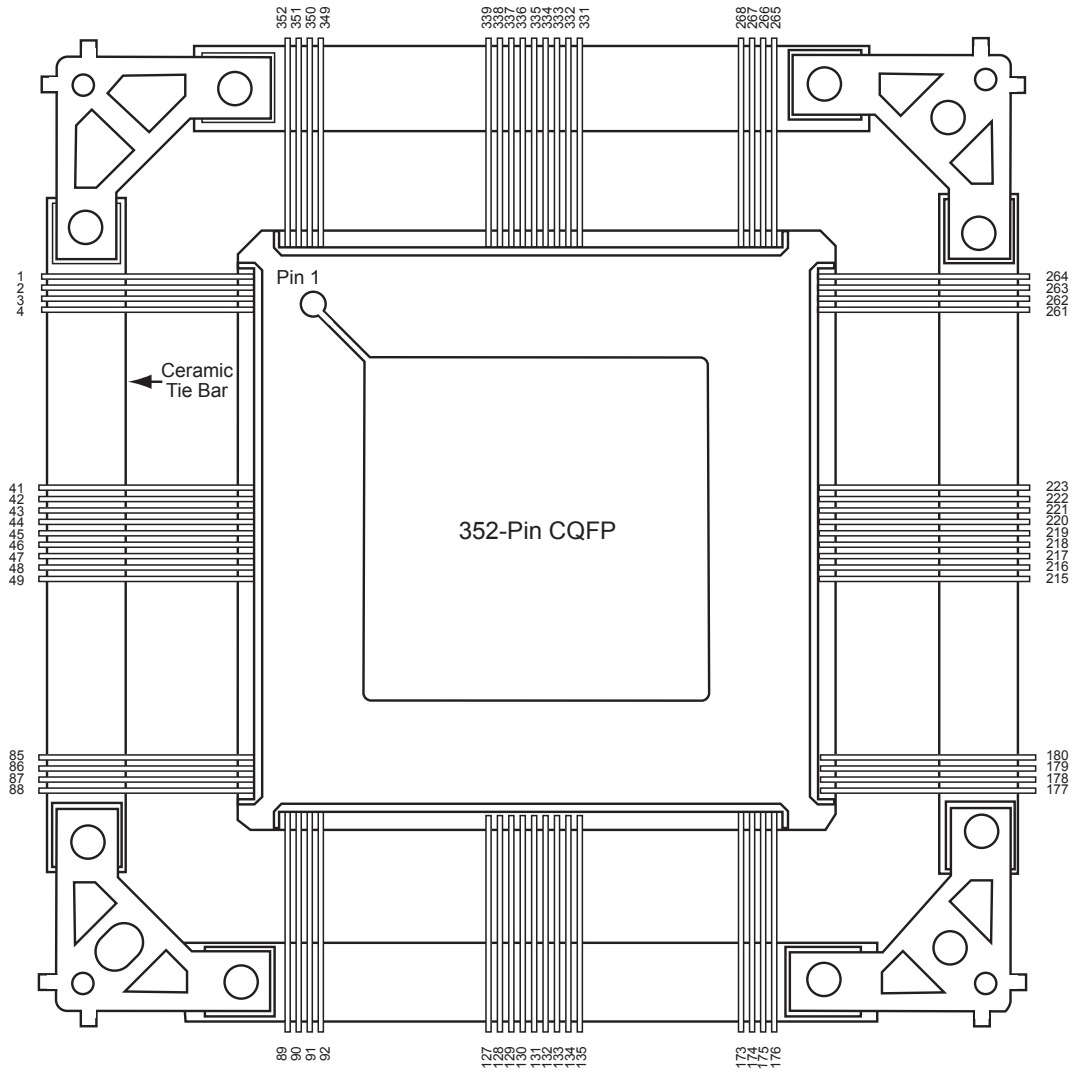

Note:

The 352-pin CQFP pin assignments for RTAX250S/SL, RTAX1000S/SL and RTAX2000S/SL are compatible except for the following pins.

	RTAX250S/SL	RTAX1000S/SL	RTAX2000S/SL	RTAX4000S/SL
RTAX250S/SL	N/A	117, 148, 294, 327, 328	91, 117, 130, 131, 148, 174, 268, 294, 307, 308, 327, 328	Not pin compatible
RTAX1000S/SL	117, 148, 294, 327, 328	N/A	91,130, 131, 174, 268, 307, 308	Not pin compatible
RTAX2000S/SL	91, 117, 130, 131, 148, 174, 268, 294, 307, 308, 327, 328	91,130, 131, 174, 268, 307, 308	NA	Not pin compatible

Where exceptions occur, the smaller density devices have those pins designated as No Connects (NC). Customers are therefore recommended to layout their board targeting the larger density device, in order to preserve interchangeability between the two devices. Note: RTAX4000S is not pin compatible with any of the smaller density devices.

For Package Manufacturing and Environmental information, visit the Resource center at <http://www.microsemi.com/soc/products/solutions/package/docs.aspx>.

CQ352	
RTAX250S/SL Function	Pin Number
Bank 0	
IO00NB0F0	341
IO00PB0F0	342
IO01NB0F0	343
IO02NB0F0	337
IO02PB0F0	338
IO04NB0F0	335
IO04PB0F0	336
IO06NB0F0	331
IO06PB0F0	332
IO08NB0F0	325
IO08PB0F0	326
IO10NB0F0	323
IO10PB0F0	324
IO12NB0F0/HCLKAN	319
IO12PB0F0/HCLKAP	320
IO13NB0F0/HCLKBN	313
IO13PB0F0/HCLKBP	314
Bank 1	
IO14NB1F1/HCLKCN	305
IO14PB1F1/HCLKCP	306
IO15NB1F1/HCLKDN	299
IO15PB1F1/HCLKDP	300
IO16NB1F1	289
IO16PB1F1	290
IO17NB1F1	295
IO17PB1F1	296
IO18NB1F1	287
IO18PB1F1	288
IO20NB1F1	283
IO20PB1F1	284
IO22NB1F1	277
IO22PB1F1	278
IO23NB1F1	281
IO23PB1F1	282

CQ352	
RTAX250S/SL Function	Pin Number
IO24NB1F1	275
IO24PB1F1	276
IO25NB1F1	271
IO25PB1F1	272
IO27NB1F1	269
IO27PB1F1	270
Bank 2	
IO29NB2F2	261
IO29PB2F2	262
IO30NB2F2	259
IO30PB2F2	260
IO31NB2F2	255
IO31PB2F2	256
IO33NB2F2	249
IO33PB2F2	250
IO34NB2F2	253
IO34PB2F2	254
IO35NB2F2	247
IO35PB2F2	248
IO36NB2F2	243
IO36PB2F2	244
IO37NB2F2	241
IO37PB2F2	242
IO38NB2F2	237
IO38PB2F2	238
IO39NB2F2	235
IO39PB2F2	236
IO41NB2F2	231
IO41PB2F2	232
IO42NB2F2	229
IO42PB2F2	230
IO43NB2F2	225
IO43PB2F2	226
IO44NB2F2	223
IO44PB2F2	224

CQ352	
RTAX250S/SL Function	Pin Number
Bank 3	
IO45NB3F3	217
IO45PB3F3	218
IO46NB3F3	219
IO46PB3F3	220
IO47NB3F3	213
IO47PB3F3	214
IO48NB3F3	211
IO48PB3F3	212
IO49NB3F3	207
IO49PB3F3	208
IO51NB3F3	205
IO51PB3F3	206
IO52NB3F3	201
IO52PB3F3	202
IO53NB3F3	199
IO53PB3F3	200
IO54NB3F3	195
IO54PB3F3	196
IO55NB3F3	193
IO55PB3F3	194
IO56NB3F3	187
IO56PB3F3	188
IO57NB3F3	189
IO57PB3F3	190
IO59NB3F3	183
IO59PB3F3	184
IO60NB3F3	181
IO60PB3F3	182
IO61NB3F3	179
IO61PB3F3	180
Bank 4	
IO62NB4F4	172
IO62PB4F4	173
IO64NB4F4	166

CQ352		CQ352		CQ352	
RTAX250S/SL Function	Pin Number	RTAX250S/SL Function	Pin Number	RTAX250S/SL Function	Pin Number
IO64PB4F4	167	IO85PB5F5	105	IO106NB6F6	46
IO65NB4F4	170	IO86NB5F5	98	IO106PB6F6	47
IO65PB4F4	171	IO86PB5F5	99	Bank 7	
IO66NB4F4	164	IO87NB5F5	94	IO107NB7F7	40
IO66PB4F4	165	IO87PB5F5	95	IO107PB7F7	41
IO67NB4F4	160	IO89NB5F5	92	IO108NB7F7	42
IO67PB4F4	161	IO89PB5F5	93	IO108PB7F7	43
IO68NB4F4	158	Bank 6		IO109NB7F7	36
IO68PB4F4	159	IO90PB6F6	86	IO109PB7F7	37
IO70NB4F4	154	IO91NB6F6	84	IO110NB7F7	34
IO70PB4F4	155	IO91PB6F6	85	IO110PB7F7	35
IO72NB4F4	152	IO92NB6F6	78	IO111NB7F7	30
IO72PB4F4	153	IO92PB6F6	79	IO111PB7F7	31
IO73NB4F4	146	IO93NB6F6	82	IO113NB7F7	28
IO73PB4F4	147	IO93PB6F6	83	IO113PB7F7	29
IO74NB4F4/CLKEN	142	IO95NB6F6	76	IO114NB7F7	24
IO74PB4F4/CLKEP	143	IO95PB6F6	77	IO114PB7F7	25
IO75NB4F4/CLKFN	136	IO96NB6F6	72	IO115NB7F7	22
IO75PB4F4/CLKFP	137	IO96PB6F6	73	IO115PB7F7	23
Bank 5		IO97NB6F6	70	IO116NB7F7	18
IO76NB5F5/CLKGN	128	IO97PB6F6	71	IO116PB7F7	19
IO76PB5F5/CLKGP	129	IO98NB6F6	66	IO117NB7F7	16
IO77NB5F5/CLKHN	122	IO98PB6F6	67	IO117PB7F7	17
IO77PB5F5/CLKHP	123	IO99NB6F6	64	IO118NB7F7	12
IO78NB5F5	112	IO99PB6F6	65	IO118PB7F7	13
IO78PB5F5	113	IO100NB6F6	60	IO119NB7F7	10
IO79NB5F5	118	IO100PB6F6	61	IO119PB7F7	11
IO79PB5F5	119	IO101NB6F6	58	IO121NB7F7	6
IO80NB5F5	110	IO101PB6F6	59	IO121PB7F7	7
IO80PB5F5	111	IO103NB6F6	54	IO123NB7F7	4
IO82NB5F5	106	IO103PB6F6	55	IO123PB7F7	5
IO82PB5F5	107	IO104NB6F6	52	Dedicated I/O	
IO84NB5F5	100	IO104PB6F6	53	GND	1
IO84PB5F5	101	IO105NB6F6	48	GND	9
IO85NB5F5	104	IO105PB6F6	49	GND	15

CQ352	
RTAX250S/SL Function	Pin Number
GND	21
GND	27
GND	33
GND	39
GND	45
GND	51
GND	57
GND	63
GND	69
GND	75
GND	81
GND	88
GND	89
GND	97
GND	103
GND	109
GND	115
GND	121
GND	133
GND	145
GND	151
GND	157
GND	163
GND	169
GND	176
GND	177
GND	186
GND	192
GND	198
GND	204
GND	210
GND	216
GND	222
GND	228
GND	234

CQ352	
RTAX250S/SL Function	Pin Number
GND	240
GND	246
GND	252
GND	258
GND	264
GND	265
GND	274
GND	280
GND	286
GND	292
GND	298
GND	310
GND	322
GND	330
GND	334
GND	340
GND	345
GND	352
NC	91
NC	117
NC	124
NC	125
NC	126
NC	127
NC	130
NC	131
NC	138
NC	139
NC	140
NC	141
NC	148
NC	174
NC	268
NC	294
NC	301

CQ352	
RTAX250S/SL Function	Pin Number
NC	302
NC	303
NC	304
NC	307
NC	308
NC	315
NC	316
NC	317
NC	318
NC	327
NC	328
PRA	312
PRB	311
PRC	135
PRD	134
TCK	349
TDI	348
TDO	347
TMS	350
TRST	351
VCCA	3
VCCA	14
VCCA	32
VCCA	56
VCCA	74
VCCA	87
VCCA	102
VCCA	114
VCCA	150
VCCA	162
VCCA	175
VCCA	191
VCCA	209
VCCA	233
VCCA	251

CQ352	
RTAX250S/SL Function	Pin Number
VCCA	263
VCCA	279
VCCA	291
VCCA	329
VCCA	339
VCCDA	2
VCCDA	44
VCCDA	90
VCCDA	116
VCCDA	132
VCCDA	149
VCCDA	178
VCCDA	221
VCCDA	266
VCCDA	293
VCCDA	309
VCCDA	346
VCCIB0	321
VCCIB0	333
VCCIB0	344
VCCIB1	273
VCCIB1	285
VCCIB1	297
VCCIB2	227
VCCIB2	239
VCCIB2	245
VCCIB2	257
VCCIB3	185
VCCIB3	197
VCCIB3	203
VCCIB3	215
VCCIB4	144
VCCIB4	156
VCCIB4	168
VCCIB5	96

CQ352	
RTAX250S/SL Function	Pin Number
VCCIB5	108
VCCIB5	120
VCCIB6	50
VCCIB6	62
VCCIB6	68
VCCIB6	80
VCCIB7	8
VCCIB7	20
VCCIB7	26
VCCIB7	38
VPUMP	267

CQ352		CQ352		CQ352	
RTAX1000S/SL Function	Pin Number	RTAX1000S/SL Function	Pin Number	RTAX1000S/SL Function	Pin Number
Bank 0		IO60NB1F5	275	Bank 3	
IO02NB0F0	341	IO60PB1F5	276	IO96NB3F9	217
IO02PB0F0	342	IO61NB1F5	271	IO96PB3F9	218
IO03PB0F0	343	IO61PB1F5	272	IO97NB3F9	219
IO04NB0F0	337	IO63NB1F5	269	IO97PB3F9	220
IO04PB0F0	338	IO63PB1F5	270	IO99NB3F9	213
IO08NB0F0	331	Bank 2		IO99PB3F9	214
IO08PB0F0	332	IO64NB2F6	259	IO108NB3F10	211
IO09NB0F0	335	IO64PB2F6	260	IO108PB3F10	212
IO09PB0F0	336	IO67NB2F6	261	IO109NB3F10	207
IO24NB0F2	325	IO67PB2F6	262	IO109PB3F10	208
IO24PB0F2	326	IO68NB2F6	255	IO111NB3F10	205
IO25NB0F2	323	IO68PB2F6	256	IO111PB3F10	206
IO25PB0F2	324	IO69NB2F6	253	IO112NB3F10	199
IO30NB0F2/HCLKAN	319	IO69PB2F6	254	IO112PB3F10	200
IO30PB0F2/HCLKAP	320	IO74NB2F7	249	IO113NB3F10	201
IO31NB0F2/HCLKBN	313	IO74PB2F7	250	IO113PB3F10	202
IO31PB0F2/HCLKBP	314	IO75NB2F7	247	IO115NB3F10	195
Bank 1		IO75PB2F7	248	IO115PB3F10	196
IO32NB1F3/HCLKCN	305	IO76NB2F7	243	IO116NB3F10	193
IO32PB1F3/HCLKCP	306	IO76PB2F7	244	IO116PB3F10	194
IO33NB1F3/HCLKDN	299	IO77NB2F7	241	IO117NB3F10	189
IO33PB1F3/HCLKDP	300	IO77PB2F7	242	IO117PB3F10	190
IO38NB1F3	295	IO78NB2F7	237	IO124NB3F11	183
IO38PB1F3	296	IO78PB2F7	238	IO124PB3F11	184
IO54NB1F5	287	IO79NB2F7	235	IO125NB3F11	187
IO54PB1F5	288	IO79PB2F7	236	IO125PB3F11	188
IO55NB1F5	289	IO82NB2F7	231	IO127NB3F11	181
IO55PB1F5	290	IO82PB2F7	232	IO127PB3F11	182
IO56NB1F5	281	IO83NB2F7	229	IO128NB3F11	179
IO56PB1F5	282	IO83PB2F7	230	IO128PB3F11	180
IO57NB1F5	283	IO94NB2F8	225	Bank 4	
IO57PB1F5	284	IO94PB2F8	226	IO130NB4F12	172
IO59NB1F5	277	IO95NB2F8	223	IO130PB4F12	173
IO59PB1F5	278	IO95PB2F8	224	IO131NB4F12	170

CQ352		CQ352		CQ352	
RTAX1000S/SL Function	Pin Number	RTAX1000S/SL Function	Pin Number	RTAX1000S/SL Function	Pin Number
IO131PB4F12	171	IO187PB5F17	99	IO224NB6F20	46
IO132NB4F12	166	IO188NB5F17	100	IO224PB6F20	47
IO132PB4F12	167	IO188PB5F17	101	Bank 7	
IO133NB4F12	164	IO190NB5F17	94	IO225NB7F21	40
IO133PB4F12	165	IO190PB5F17	95	IO225PB7F21	41
IO134NB4F12	160	IO192NB5F17	92	IO226NB7F21	42
IO134PB4F12	161	IO192PB5F17	93	IO226PB7F21	43
IO136NB4F12	158	Bank 6		IO237NB7F22	34
IO136PB4F12	159	IO193PB6F18	86	IO237PB7F22	35
IO137NB4F12	154	IO194NB6F18	84	IO238NB7F22	36
IO137PB4F12	155	IO194PB6F18	85	IO238PB7F22	37
IO138NB4F12	152	IO196NB6F18	78	IO240NB7F22	30
IO138PB4F12	153	IO196PB6F18	79	IO240PB7F22	31
IO153NB4F14	146	IO197NB6F18	82	IO241NB7F22	28
IO153PB4F14	147	IO197PB6F18	83	IO241PB7F22	29
IO159NB4F14/CLKEN	142	IO198NB6F18	76	IO242NB7F22	24
IO159PB4F14/CLKEP	143	IO198PB6F18	77	IO242PB7F22	25
IO160NB4F14/CLKFN	136	IO203NB6F19	72	IO244NB7F22	22
IO160PB4F14/CLKFP	137	IO203PB6F19	73	IO244PB7F22	23
Bank 5		IO204NB6F19	70	IO245NB7F22	18
IO161NB5F15/CLKGN	128	IO204PB6F19	71	IO245PB7F22	19
IO161PB5F15/CLKGP	129	IO205NB6F19	66	IO246NB7F22	16
IO162NB5F15/CLKHN	122	IO205PB6F19	67	IO246PB7F22	17
IO162PB5F15/CLKHP	123	IO206NB6F19	64	IO249NB7F23	12
IO167NB5F15	118	IO206PB6F19	65	IO249PB7F23	13
IO167PB5F15	119	IO207NB6F19	60	IO250NB7F23	10
IO183NB5F17	110	IO207PB6F19	61	IO250PB7F23	11
IO183PB5F17	111	IO208NB6F19	58	IO256NB7F23	4
IO184NB5F17	112	IO208PB6F19	59	IO256PB7F23	5
IO184PB5F17	113	IO211NB6F19	54	IO257NB7F23	6
IO185NB5F17	104	IO211PB6F19	55	IO257PB7F23	7
IO185PB5F17	105	IO212NB6F19	52	Dedicated I/O	
IO186NB5F17	106	IO212PB6F19	53	GND	1
IO186PB5F17	107	IO223NB6F20	48	GND	9
IO187NB5F17	98	IO223PB6F20	49	GND	15

CQ352		CQ352		CQ352	
RTAX1000S/SL Function	Pin Number	RTAX1000S/SL Function	Pin Number	RTAX1000S/SL Function	Pin Number
GND	21	GND	240	NC	307
GND	27	GND	246	NC	308
GND	33	GND	252	NC	315
GND	39	GND	258	NC	316
GND	45	GND	264	NC	317
GND	51	GND	265	NC	318
GND	57	GND	274	PRA	312
GND	63	GND	280	PRB	311
GND	69	GND	286	PRC	135
GND	75	GND	292	PRD	134
GND	81	GND	298	TCK	349
GND	88	GND	310	TDI	348
GND	89	GND	322	TDO	347
GND	97	GND	330	TMS	350
GND	103	GND	334	TRST	351
GND	109	GND	340	VCCA	3
GND	115	GND	345	VCCA	14
GND	121	GND	352	VCCA	32
GND	133	NC	91	VCCA	56
GND	145	NC	124	VCCA	74
GND	151	NC	125	VCCA	87
GND	157	NC	126	VCCA	102
GND	163	NC	127	VCCA	114
GND	169	NC	130	VCCA	150
GND	176	NC	131	VCCA	162
GND	177	NC	138	VCCA	175
GND	186	NC	139	VCCA	191
GND	192	NC	140	VCCA	209
GND	198	NC	141	VCCA	233
GND	204	NC	174	VCCA	251
GND	210	NC	268	VCCA	263
GND	216	NC	301	VCCA	279
GND	222	NC	302	VCCA	291
GND	228	NC	303	VCCA	329
GND	234	NC	304	VCCA	339

CQ352	
RTAX1000S/SL Function	Pin Number
VCCDA	2
VCCDA	44
VCCDA	90
VCCDA	116
VCCDA	117
VCCDA	132
VCCDA	148
VCCDA	149
VCCDA	178
VCCDA	221
VCCDA	266
VCCDA	293
VCCDA	294
VCCDA	309
VCCDA	327
VCCDA	328
VCCDA	346
VCCIB0	321
VCCIB0	333
VCCIB0	344
VCCIB1	273
VCCIB1	285
VCCIB1	297
VCCIB2	227
VCCIB2	239
VCCIB2	245
VCCIB2	257
VCCIB3	185
VCCIB3	197
VCCIB3	203
VCCIB3	215
VCCIB4	144
VCCIB4	156
VCCIB4	168
VCCIB5	96

CQ352	
RTAX1000S/SL Function	Pin Number
VCCIB5	108
VCCIB5	120
VCCIB6	50
VCCIB6	62
VCCIB6	68
VCCIB6	80
VCCIB7	8
VCCIB7	20
VCCIB7	26
VCCIB7	38
VPUMP	267

CQ352		CQ352		CQ352	
RTAX2000S/SL Function	Pin Number	RTAX2000S/SL Function	Pin Number	RTAX2000S/SL Function	Pin Number
Bank 0		IO71NB1F6	277	Bank 3	
IO01NB0F0	341	IO71PB1F6	278	IO129NB3F12	219
IO01PB0F0	342	IO73NB1F6	269	IO129PB3F12	220
IO02PB0F0	343	IO73PB1F6	270	IO132NB3F12	217
IO04NB0F0	337	IO74NB1F6	271	IO132PB3F12	218
IO04PB0F0	338	IO74PB1F6	272	IO137NB3F12	213
IO05NB0F0	335	Bank 2		IO137PB3F12	214
IO05PB0F0	336	IO87NB2F8	261	IO139NB3F13	211
IO08NB0F0	331	IO87PB2F8	262	IO139PB3F13	212
IO08PB0F0	332	IO88NB2F8	255	IO141NB3F13	205
IO37NB0F3	325	IO88PB2F8	256	IO141PB3F13	206
IO37PB0F3	326	IO89NB2F8	259	IO142NB3F13	207
IO38NB0F3	323	IO89PB2F8	260	IO142PB3F13	208
IO38PB0F3	324	IO91NB2F8	253	IO145NB3F13	199
IO41NB0F3/HCLKAN	319	IO91PB2F8	254	IO145PB3F13	200
IO41PB0F3/HCLKAP	320	IO99NB2F9	249	IO146NB3F13	201
IO42NB0F3/HCLKBN	313	IO99PB2F9	250	IO146PB3F13	202
IO42PB0F3/HCLKBP	314	IO100NB2F9	247	IO147NB3F13	193
Bank 1		IO100PB2F9	248	IO147PB3F13	194
IO43NB1F4/HCLKCN	305	IO107NB2F10	243	IO148NB3F13	195
IO43PB1F4/HCLKCP	306	IO107PB2F10	244	IO148PB3F13	196
IO44NB1F4/HCLKDN	299	IO110NB2F10	241	IO149NB3F13	189
IO44PB1F4/HCLKDP	300	IO110PB2F10	242	IO149PB3F13	190
IO48NB1F4	295	IO111NB2F10	237	IO161NB3F15	183
IO48PB1F4	296	IO111PB2F10	238	IO161PB3F15	184
IO65NB1F6	283	IO112NB2F10	235	IO163NB3F15	187
IO65PB1F6	284	IO112PB2F10	236	IO163PB3F15	188
IO66NB1F6	289	IO113NB2F10	231	IO165NB3F15	181
IO66PB1F6	290	IO113PB2F10	232	IO165PB3F15	182
IO68NB1F6	287	IO114NB2F10	229	IO167NB3F15	179
IO68PB1F6	288	IO114PB2F10	230	IO167PB3F15	180
IO69NB1F6	275	IO115NB2F10	225	Bank 4	
IO69PB1F6	276	IO115PB2F10	226	IO181NB4F17	172
IO70NB1F6	281	IO117NB2F10	223	IO181PB4F17	173
IO70PB1F6	282	IO117PB2F10	224	IO182NB4F17	170

CQ352		CQ352		CQ352	
RTAX2000S/SL Function	Pin Number	RTAX2000S/SL Function	Pin Number	RTAX2000S/SL Function	Pin Number
IO182PB4F17	171	IO240PB5F22	101	IO296NB6F27	46
IO183NB4F17	166	IO242NB5F22	94	IO296PB6F27	47
IO183PB4F17	167	IO242PB5F22	95	Bank 7	
IO184NB4F17	164	IO243NB5F22	98	IO300NB7F28	42
IO184PB4F17	165	IO243PB5F22	99	IO300PB7F28	43
IO185NB4F17	160	IO244NB5F22	92	IO303NB7F28	40
IO185PB4F17	161	IO244PB5F22	93	IO303PB7F28	41
IO190NB4F17	158	Bank 6		IO310NB7F29	34
IO190PB4F17	159	IO257PB6F24	86	IO310PB7F29	35
IO191NB4F17	154	IO258NB6F24	84	IO311NB7F29	36
IO191PB4F17	155	IO258PB6F24	85	IO311PB7F29	37
IO192NB4F17	152	IO261NB6F24	82	IO312NB7F29	28
IO192PB4F17	153	IO261PB6F24	83	IO312PB7F29	29
IO207NB4F19	146	IO262NB6F24	78	IO315NB7F29	30
IO207PB4F19	147	IO262PB6F24	79	IO315PB7F29	31
IO212NB4F19/CLKEN	142	IO265NB6F24	76	IO316NB7F29	22
IO212PB4F19/CLKEP	143	IO265PB6F24	77	IO316PB7F29	23
IO213NB4F19/CLKFN	136	IO279NB6F26	72	IO317NB7F29	24
IO213PB4F19/CLKFP	137	IO279PB6F26	73	IO317PB7F29	25
Bank 5		IO280NB6F26	70	IO318NB7F29	18
IO214NB5F20/CLKGN	128	IO280PB6F26	71	IO318PB7F29	19
IO214PB5F20/CLKGP	129	IO281NB6F26	66	IO320NB7F29	16
IO215NB5F20/CLKHN	122	IO281PB6F26	67	IO320PB7F29	17
IO215PB5F20/CLKHP	123	IO282NB6F26	64	IO334NB7F31	10
IO217NB5F20	118	IO282PB6F26	65	IO334PB7F31	11
IO217PB5F20	119	IO284NB6F26	60	IO335NB7F31	12
IO236NB5F22	110	IO284PB6F26	61	IO335PB7F31	13
IO236PB5F22	111	IO285NB6F26	58	IO338NB7F31	6
IO237NB5F22	112	IO285PB6F26	59	IO338PB7F31	7
IO237PB5F22	113	IO286NB6F26	54	IO341NB7F31	4
IO238NB5F22	104	IO286PB6F26	55	IO341PB7F31	5
IO238PB5F22	105	IO287NB6F26	52	Dedicated I/O	
IO239NB5F22	106	IO287PB6F26	53	GND	1
IO239PB5F22	107	IO294NB6F27	48	GND	9
IO240NB5F22	100	IO294PB6F27	49	GND	15

CQ352		CQ352		CQ352	
RTAX2000S/SL Function	Pin Number	RTAX2000S/SL Function	Pin Number	RTAX2000S/SL Function	Pin Number
GND	21	GND	240	PRB	311
GND	27	GND	246	PRC	135
GND	33	GND	252	PRD	134
GND	39	GND	258	TCK	349
GND	45	GND	264	TDI	348
GND	51	GND	265	TDO	347
GND	57	GND	274	TMS	350
GND	63	GND	280	TRST	351
GND	69	GND	286	VCCA	3
GND	75	GND	292	VCCA	14
GND	81	GND	298	VCCA	32
GND	88	GND	310	VCCA	56
GND	89	GND	322	VCCA	74
GND	97	GND	330	VCCA	87
GND	103	GND	334	VCCA	102
GND	109	GND	340	VCCA	114
GND	115	GND	345	VCCA	150
GND	121	GND	352	VCCA	162
GND	133	NC	124	VCCA	175
GND	145	NC	125	VCCA	191
GND	151	NC	126	VCCA	209
GND	157	NC	127	VCCA	233
GND	163	NC	138	VCCA	251
GND	169	NC	139	VCCA	263
GND	176	NC	140	VCCA	279
GND	177	NC	141	VCCA	291
GND	186	NC	301	VCCA	329
GND	192	NC	302	VCCA	339
GND	198	NC	303	VCCDA	2
GND	204	NC	304	VCCDA	44
GND	210	NC	315	VCCDA	90
GND	216	NC	316	VCCDA	91
GND	222	NC	317	VCCDA	116
GND	228	NC	318	VCCDA	117
GND	234	PRA	312	VCCDA	130

CQ352		CQ352	
RTAX2000S/SL Function	Pin Number	RTAX2000S/SL Function	Pin Number
VCCDA	131	VCCIB5	108
VCCDA	132	VCCIB5	120
VCCDA	148	VCCIB6	50
VCCDA	149	VCCIB6	62
VCCDA	174	VCCIB6	68
VCCDA	178	VCCIB6	80
VCCDA	221	VCCIB7	8
VCCDA	266	VCCIB7	20
VCCDA	268	VCCIB7	26
VCCDA	293	VCCIB7	38
VCCDA	294	VPUMP	267
VCCDA	307		
VCCDA	308		
VCCDA	309		
VCCDA	327		
VCCDA	328		
VCCDA	346		
VCCIB0	321		
VCCIB0	333		
VCCIB0	344		
VCCIB1	273		
VCCIB1	285		
VCCIB1	297		
VCCIB2	227		
VCCIB2	239		
VCCIB2	245		
VCCIB2	257		
VCCIB3	185		
VCCIB3	197		
VCCIB3	203		
VCCIB3	215		
VCCIB4	144		
VCCIB4	156		
VCCIB4	168		
VCCIB5	96		

CQ352	
RTAX4000S/SL Function	Pin Number
Bank 0	
IO02NB0F0	341
IO02PB0F0	342
IO03PB0F0	343
IO05NB0F0	337
IO05PB0F0	338
IO06NB0F0	335
IO06PB0F0	336
IO07NB0F0	331
IO07PB0F0	332
IO11NB0F0	329
IO11PB0F0	330
IO50NB0F4/HCLKAN	317
IO50PB0F4/HCLKAP	318
IO51NB0F4/HCLKBN	313
IO51PB0F4/HCLKBP	314
Bank 1	
IO52NB1F6/HCLKCN	303
IO52PB1F6/HCLKCP	304
IO53NB1F6/HCLKDN	299
IO53PB1F6/HCLKDP	300
IO94NB1F10	287
IO94PB1F10	288
IO97NB1F10	281
IO97PB1F10	282
IO98NB1F10	285
IO98PB1F10	286
IO99NB1F10	275
IO99PB1F10	276
IO100NB1F10	279
IO100PB1F10	280
IO102NB1F10	273
IO102PB1F10	274
IO103NB1F10	269
IO103PB1F10	270

CQ352	
RTAX4000S/SL Function	Pin Number
Bank 2	
IO104NB2F12	259
IO104PB2F12	260
IO106NB2F12	253
IO106PB2F12	254
IO107NB2F12	257
IO107PB2F12	258
IO111NB2F12	251
IO111PB2F12	252
IO139NB2F16	241
IO139PB2F16	242
IO140NB2F16	245
IO140PB2F16	246
IO141NB2F16	235
IO141PB2F16	236
IO142NB2F16	239
IO142PB2F16	240
IO143NB2F16	229
IO143PB2F16	230
IO144NB2F16	233
IO144PB2F16	234
IO145NB2F16	223
IO145PB2F16	224
IO146NB2F16	227
IO146PB2F16	228
Bank 3	
IO175NB3F20	213
IO175PB3F20	214
IO176NB3F20	217
IO176PB3F20	218
IO177NB3F20	207
IO177PB3F20	208
IO178NB3F20	211
IO178PB3F20	212
IO179NB3F20	205

CQ352	
RTAX4000S/SL Function	Pin Number
IO179PB3F20	206
IO181NB3F20	201
IO181PB3F20	202
IO182NB3F20	199
IO182PB3F20	200
IO183NB3F20	195
IO183PB3F20	196
IO203NB3F23	189
IO203PB3F23	190
IO204NB3F23	183
IO204PB3F23	184
IO206NB3F23	187
IO206PB3F23	188
IO209NB3F23	181
IO209PB3F23	182
Bank 4	
IO210NB4F24	167
IO210PB4F24	168
IO211NB4F24	173
IO213NB4F24	171
IO213PB4F24	172
IO214NB4F24	161
IO214PB4F24	162
IO215NB4F24	165
IO215PB4F24	166
IO216NB4F24	155
IO216PB4F24	156
IO217NB4F24	159
IO217PB4F24	160
IO219NB4F24	153
IO219PB4F24	154
IO260NB4F28/CLKEN	141
IO260PB4F28/CLKEP	142
IO261NB4F28/CLKFN	137
IO261PB4F28/CLKFP	138

CQ352	
RTAX4000S/SL Function	Pin Number
Bank 5	
IO262NB5F30/CLKGN	127
IO262PB5F30/CLKGP	128
IO263NB5F30/CLKHN	123
IO263PB5F30/CLKHP	124
IO304NB5F34	111
IO304PB5F34	112
IO305NB5F34	109
IO305PB5F34	110
IO307NB5F34	103
IO307PB5F34	104
IO308NB5F34	105
IO308PB5F34	106
IO309NB5F34	97
IO309PB5F34	98
IO310NB5F34	99
IO310PB5F34	100
IO312NB5F34	93
IO312PB5F34	94
IO313NB5F34	92
Bank 6	
IO314PB6F36	84
IO316NB6F36	82
IO316PB6F36	83
IO317NB6F36	78
IO317PB6F36	79
IO319NB6F36	76
IO319PB6F36	77
IO349NB6F40	66
IO349PB6F40	67
IO350NB6F40	70
IO350PB6F40	71
IO351NB6F40	60
IO351PB6F40	61
IO352NB6F40	64

CQ352	
RTAX4000S/SL Function	Pin Number
IO352PB6F40	65
IO353NB6F40	54
IO353PB6F40	55
IO354NB6F40	58
IO354PB6F40	59
IO355NB6F40	48
IO355PB6F40	49
IO356NB6F40	52
IO356PB6F40	53
Bank 7	
IO385NB7F44	42
IO385PB7F44	43
IO386NB7F44	38
IO386PB7F44	39
IO387NB7F44	36
IO387PB7F44	37
IO388NB7F44	32
IO388PB7F44	33
IO389NB7F44	30
IO389PB7F44	31
IO391NB7F44	26
IO391PB7F44	27
IO392NB7F44	24
IO392PB7F44	25
IO393NB7F44	20
IO393PB7F44	21
IO413NB7F47	14
IO413PB7F47	15
IO414NB7F47	8
IO414PB7F47	9
IO416NB7F47	12
IO416PB7F47	13
IO419NB7F47	6
IO419PB7F47	7
Dedicated I/O	

CQ352	
RTAX4000S/SL Function	Pin Number
GND	1
GND	5
GND	11
GND	17
GND	19
GND	23
GND	29
GND	35
GND	41
GND	45
GND	47
GND	51
GND	57
GND	63
GND	69
GND	73
GND	75
GND	81
GND	86
GND	88
GND	89
GND	96
GND	102
GND	108
GND	117
GND	119
GND	126
GND	132
GND	134
GND	140
GND	147
GND	149
GND	158
GND	164
GND	170

CQ352	
RTAX4000S/SL Function	Pin Number
GND	176
GND	177
GND	180
GND	186
GND	192
GND	194
GND	198
GND	204
GND	210
GND	216
GND	220
GND	222
GND	226
GND	232
GND	238
GND	244
GND	248
GND	250
GND	256
GND	262
GND	264
GND	265
GND	272
GND	278
GND	284
GND	293
GND	295
GND	302
GND	308
GND	310
GND	316
GND	323
GND	325
GND	334
GND	340

CQ352	
RTAX4000S/SL Function	Pin Number
GND	345
GND	352
PRA	312
PRB	311
PRC	136
PRD	135
TCK	349
TDI	348
TDO	347
TMS	350
TRST	351
VCCA	3
VCCA	4
VCCA	18
VCCA	34
VCCA	44
VCCA	56
VCCA	72
VCCA	85
VCCA	87
VCCA	101
VCCA	116
VCCA	129
VCCA	131
VCCA	148
VCCA	163
VCCA	175
VCCA	179
VCCA	193
VCCA	209
VCCA	219
VCCA	231
VCCA	247
VCCA	261
VCCA	263

CQ352	
RTAX4000S/SL Function	Pin Number
VCCA	277
VCCA	292
VCCA	305
VCCA	307
VCCA	324
VCCA	339
VCCDA	2
VCCDA	16
VCCDA	46
VCCDA	74
VCCDA	90
VCCDA	91
VCCDA	113
VCCDA	114
VCCDA	115
VCCDA	118
VCCDA	120
VCCDA	121
VCCDA	122
VCCDA	130
VCCDA	133
VCCDA	143
VCCDA	144
VCCDA	145
VCCDA	146
VCCDA	150
VCCDA	151
VCCDA	152
VCCDA	174
VCCDA	178
VCCDA	191
VCCDA	221
VCCDA	249
VCCDA	266
VCCDA	268

CQ352	
RTAX4000S/SL Function	Pin Number
VCCDA	289
VCCDA	290
VCCDA	291
VCCDA	294
VCCDA	296
VCCDA	297
VCCDA	298
VCCDA	306
VCCDA	309
VCCDA	319
VCCDA	320
VCCDA	321
VCCDA	322
VCCDA	326
VCCDA	327
VCCDA	328
VCCDA	346
VCCIB0	315
VCCIB0	333
VCCIB0	344
VCCIB1	271
VCCIB1	283
VCCIB1	301
VCCIB2	225
VCCIB2	237
VCCIB2	243
VCCIB2	255
VCCIB3	185
VCCIB3	197
VCCIB3	203
VCCIB3	215
VCCIB4	139
VCCIB4	157
VCCIB4	169
VCCIB5	95

CQ352	
RTAX4000S/SL Function	Pin Number
VCCIB5	107
VCCIB5	125
VCCIB6	50
VCCIB6	62
VCCIB6	68
VCCIB6	80
VCCIB7	10
VCCIB7	22
VCCIB7	28
VCCIB7	40
VPUMP	267

CQ352	
RTAX2000D Function	Pin Number
Bank 0	
IO01PB0F0	343
IO05NB0F0	341
IO05PB0F0	342
IO13NB0F1	337
IO13PB0F1	338
IO17NB0F1	335
IO17PB0F1	336
IO25NB0F2	331
IO25PB0F2	332
IO29NB0F2	329
IO29PB0F2	330
IO41NB0F3/HCLKAN	317
IO41PB0F3/HCLKAP	318
IO42NB0F3/HCLKBN	313
IO42PB0F3/HCLKBP	314
Bank 1	
IO43NB1F4/HCLKCN	303
IO43PB1F4/HCLKCP	304
IO44NB1F4/HCLKDN	299
IO44PB1F4/HCLKDP	300
IO53NB1F4	287
IO53PB1F4	288
IO57NB1F5	285
IO57PB1F5	286
IO61NB1F5	281
IO61PB1F5	282
IO65NB1F6	279
IO65PB1F6	280
IO69NB1F6	275
IO69PB1F6	276
IO77NB1F7	273
IO77PB1F7	274
IO81NB1F7	269
IO81PB1F7	270

CQ352	
RTAX2000D Function	Pin Number
Bank 2	
IO87NB2F8	259
IO87PB2F8	260
IO91NB2F8	257
IO91PB2F8	258
IO95NB2F8	253
IO95PB2F8	254
IO99NB2F9	251
IO99PB2F9	252
IO103NB2F9	245
IO103PB2F9	246
IO107NB2F10	241
IO107PB2F10	242
IO111NB2F10	239
IO111PB2F10	240
IO115NB2F10	235
IO115PB2F10	236
IO119NB2F11	233
IO119PB2F11	234
IO121NB2F11	229
IO121PB2F11	230
IO123NB2F11	227
IO123PB2F11	228
IO127NB2F11	223
IO127PB2F11	224
Bank 3	
IO131NB3F12	217
IO131PB3F12	218
IO135NB3F12	213
IO135PB3F12	214
IO137NB3F12	211
IO137PB3F12	212
IO139NB3F13	207
IO139PB3F13	208
IO143NB3F13	205

CQ352	
RTAX2000D Function	Pin Number
IO143PB3F13	206
IO147NB3F13	201
IO147PB3F13	202
IO151NB3F14	199
IO151PB3F14	200
IO155NB3F14	195
IO155PB3F14	196
IO159NB3F14	189
IO159PB3F14	190
IO163NB3F15	187
IO163PB3F15	188
IO167NB3F15	183
IO167PB3F15	184
IO170NB3F15	181
IO170PB3F15	182
Bank 4	
IO172NB4F16	173
IO176NB4F16	171
IO176PB4F16	172
IO184NB4F17	167
IO184PB4F17	168
IO188NB4F17	165
IO188PB4F17	166
IO192NB4F17	161
IO192PB4F17	162
IO196NB4F18	159
IO196PB4F18	160
IO200NB4F18	155
IO200PB4F18	156
IO208NB4F19	153
IO208PB4F19	154
IO212NB4F19/CLKEN	141
IO212PB4F19/CLKEP	142
IO213NB4F19/CLKFN	137
IO213PB4F19/CLKFP	138

CQ352		CQ352		CQ352	
RTAX2000D Function	Pin Number	RTAX2000D Function	Pin Number	RTAX2000D Function	Pin Number
Bank 5		IO282PB6F26	61	GND	1
IO214NB5F20/CLKGN	127	IO286NB6F26	58	GND	5
IO214PB5F20/CLKGP	128	IO286PB6F26	59	GND	11
IO215NB5F20/CLKHN	123	IO290NB6F27	54	GND	19
IO215PB5F20/CLKHP	124	IO290PB6F27	55	GND	23
IO218NB5F20	111	IO294NB6F27	52	GND	29
IO218PB5F20	112	IO294PB6F27	53	GND	35
IO228NB5F21	109	IO298NB6F27	48	GND	41
IO228PB5F21	110	IO298PB6F27	49	GND	47
IO232NB5F21	105	Bank 7		GND	51
IO232PB5F21	106	IO302NB7F28	42	GND	57
IO236NB5F22	103	IO302PB7F28	43	GND	63
IO236PB5F22	104	IO306NB7F28	38	GND	69
IO240NB5F22	99	IO306PB7F28	39	GND	73
IO240PB5F22	100	IO308NB7F28	32	GND	81
IO246NB5F23	97	IO308PB7F28	33	GND	86
IO246PB5F23	98	IO310NB7F29	36	GND	88
IO248NB5F23	92	IO310PB7F29	37	GND	89
IO252NB5F23	93	IO314NB7F29	30	GND	96
IO252PB5F23	94	IO314PB7F29	31	GND	102
Bank 6		IO318NB7F29	26	GND	108
IO257PB6F24	84	IO318PB7F29	27	GND	117
IO258NB6F24	82	IO322NB7F30	24	GND	126
IO258PB6F24	83	IO322PB7F30	25	GND	132
IO262NB6F24	78	IO326NB7F30	20	GND	134
IO262PB6F24	79	IO326PB7F30	21	GND	140
IO266NB6F24	76	IO330NB7F30	14	GND	149
IO266PB6F24	77	IO330PB7F30	15	GND	158
IO270NB6F25	70	IO334NB7F31	12	GND	164
IO270PB6F25	71	IO334PB7F31	13	GND	170
IO274NB6F25	66	IO338NB7F31	8	GND	176
IO274PB6F25	67	IO338PB7F31	9	GND	177
IO278NB6F26	64	IO341NB7F31	6	GND	180
IO278PB6F26	65	IO341PB7F31	7	GND	186
IO282NB6F26	60	Dedicated I/O		GND	194

CQ352	
RTAX2000D Function	Pin Number
GND	198
GND	204
GND	210
GND	216
GND	222
GND	226
GND	232
GND	238
GND	244
GND	248
GND	256
GND	262
GND	264
GND	265
GND	272
GND	278
GND	284
GND	293
GND	302
GND	308
GND	310
GND	316
GND	325
GND	334
GND	340
GND	345
GND	352
NC	16
NC	17
NC	44
NC	45
NC	74
NC	75
NC	113
NC	118

CQ352	
RTAX2000D Function	Pin Number
NC	119
NC	120
NC	122
NC	129
NC	143
NC	144
NC	146
NC	147
NC	151
NC	152
NC	191
NC	192
NC	219
NC	220
NC	249
NC	250
NC	289
NC	294
NC	295
NC	296
NC	298
NC	305
NC	319
NC	320
NC	322
NC	323
NC	327
NC	328
PRA	312
PRB	311
PRC	136
PRD	135
TCK	349
TDI	348
TDO	347

CQ352	
RTAX2000D Function	Pin Number
TMS	350
TRST	351
VCCA	3
VCCA	87
VCCA	175
VCCA	263
VCCA	4
VCCA	18
VCCA	34
VCCA	56
VCCA	72
VCCA	85
VCCA	101
VCCA	116
VCCA	131
VCCA	148
VCCA	163
VCCA	179
VCCA	193
VCCA	209
VCCA	231
VCCA	247
VCCA	261
VCCA	277
VCCA	292
VCCA	307
VCCA	324
VCCA	339
VCCDA	2
VCCDA	46
VCCDA	90
VCCDA	91
VCCDA	114
VCCDA	115
VCCDA	121

CQ352	
RTAX2000D Function	Pin Number
VCCDA	130
VCCDA	133
VCCDA	145
VCCDA	150
VCCDA	174
VCCDA	178
VCCDA	221
VCCDA	266
VCCDA	268
VCCDA	290
VCCDA	291
VCCDA	297
VCCDA	306
VCCDA	309
VCCDA	321
VCCDA	326
VCCDA	346
VCCIB0	315
VCCIB0	333
VCCIB0	344
VCCIB1	271
VCCIB1	283
VCCIB1	301
VCCIB2	225
VCCIB2	237
VCCIB2	243
VCCIB2	255
VCCIB3	185
VCCIB3	197
VCCIB3	203
VCCIB3	215
VCCIB4	139
VCCIB4	157
VCCIB4	169
VCCIB5	95

CQ352	
RTAX2000D Function	Pin Number
VCCIB5	107
VCCIB5	125
VCCIB6	50
VCCIB6	62
VCCIB6	68
VCCIB6	80
VCCIB7	10
VCCIB7	22
VCCIB7	28
VCCIB7	40
VPUMP	267

CQ352	
RTAX4000D Function	Pin Number
Bank 0	
IO02NB0F0	341
IO02PB0F0	342
IO03PB0F0	343
IO05NB0F0	337
IO05PB0F0	338
IO06NB0F0	335
IO06PB0F0	336
IO07NB0F0	331
IO07PB0F0	332
IO11NB0F0	329
IO11PB0F0	330
IO50NB0F4/HCLKAN	317
IO50PB0F4/HCLKAP	318
IO51NB0F4/HCLKBN	313
IO51PB0F4/HCLKBP	314
Bank 1	
IO52NB1F6/HCLKCN	303
IO52PB1F6/HCLKCP	304
IO53NB1F6/HCLKDN	299
IO53PB1F6/HCLKDP	300
IO94NB1F10	287
IO94PB1F10	288
IO97NB1F10	281
IO97PB1F10	282
IO98NB1F10	285
IO98PB1F10	286
IO99NB1F10	275
IO99PB1F10	276
IO100NB1F10	279
IO100PB1F10	280
IO102NB1F10	273
IO102PB1F10	274
IO103NB1F10	269
IO103PB1F10	270

CQ352	
RTAX4000D Function	Pin Number
Bank 2	
IO104NB2F12	259
IO104PB2F12	260
IO106NB2F12	253
IO106PB2F12	254
IO107NB2F12	257
IO107PB2F12	258
IO111NB2F12	251
IO111PB2F12	252
IO139NB2F16	241
IO139PB2F16	242
IO140NB2F16	245
IO140PB2F16	246
IO141NB2F16	235
IO141PB2F16	236
IO142NB2F16	239
IO142PB2F16	240
IO143NB2F16	229
IO143PB2F16	230
IO144NB2F16	233
IO144PB2F16	234
IO145NB2F16	223
IO145PB2F16	224
IO146NB2F16	227
IO146PB2F16	228
Bank 3	
IO175NB3F20	213
IO175PB3F20	214
IO176NB3F20	217
IO176PB3F20	218
IO177NB3F20	207
IO177PB3F20	208
IO178NB3F20	211
IO178PB3F20	212
IO179NB3F20	205

CQ352	
RTAX4000D Function	Pin Number
IO179PB3F20	206
IO181NB3F20	201
IO181PB3F20	202
IO182NB3F20	199
IO182PB3F20	200
IO183NB3F20	195
IO183PB3F20	196
IO203NB3F23	189
IO203PB3F23	190
IO204NB3F23	183
IO204PB3F23	184
IO206NB3F23	187
IO206PB3F23	188
IO209NB3F23	181
IO209PB3F23	182
Bank 4	
IO210NB4F24	167
IO210PB4F24	168
IO211NB4F24	173
IO213NB4F24	171
IO213PB4F24	172
IO214NB4F24	161
IO214PB4F24	162
IO215NB4F24	165
IO215PB4F24	166
IO216NB4F24	155
IO216PB4F24	156
IO217NB4F24	159
IO217PB4F24	160
IO219NB4F24	153
IO219PB4F24	154
IO260NB4F28/CLKEN	141
IO260PB4F28/CLKEP	142
IO261NB4F28/CLKFN	137
IO261PB4F28/CLKFP	138

CQ352		CQ352		CQ352	
RTAX4000D Function	Pin Number	RTAX4000D Function	Pin Number	RTAX4000D Function	Pin Number
Bank 5		IO352PB6F40	65	GND	1
IO262NB5F30/CLKGN	127	IO353NB6F40	54	GND	5
IO262PB5F30/CLKGP	128	IO353PB6F40	55	GND	11
IO263NB5F30/CLKHN	123	IO354NB6F40	58	GND	17
IO263PB5F30/CLKHP	124	IO354PB6F40	59	GND	19
IO304NB5F34	111	IO355NB6F40	48	GND	23
IO304PB5F34	112	IO355PB6F40	49	GND	29
IO305NB5F34	109	IO356NB6F40	52	GND	35
IO305PB5F34	110	IO356PB6F40	53	GND	41
IO307NB5F34	103	Bank 7		GND	45
IO307PB5F34	104	IO385NB7F44	42	GND	47
IO308NB5F34	105	IO385PB7F44	43	GND	51
IO308PB5F34	106	IO386NB7F44	38	GND	57
IO309NB5F34	97	IO386PB7F44	39	GND	63
IO309PB5F34	98	IO387NB7F44	36	GND	69
IO310NB5F34	99	IO387PB7F44	37	GND	73
IO310PB5F34	100	IO388NB7F44	32	GND	75
IO312NB5F34	93	IO388PB7F44	33	GND	81
IO312PB5F34	94	IO389NB7F44	30	GND	86
IO313NB5F34	92	IO389PB7F44	31	GND	88
Bank 6		IO391NB7F44	26	GND	89
IO314PB6F36	84	IO391PB7F44	27	GND	96
IO316NB6F36	82	IO392NB7F44	24	GND	102
IO316PB6F36	83	IO392PB7F44	25	GND	108
IO317NB6F36	78	IO393NB7F44	20	GND	117
IO317PB6F36	79	IO393PB7F44	21	GND	119
IO319NB6F36	76	IO413NB7F47	14	GND	126
IO319PB6F36	77	IO413PB7F47	15	GND	132
IO349NB6F40	66	IO414NB7F47	8	GND	134
IO349PB6F40	67	IO414PB7F47	9	GND	140
IO350NB6F40	70	IO416NB7F47	12	GND	147
IO350PB6F40	71	IO416PB7F47	13	GND	149
IO351NB6F40	60	IO419NB7F47	6	GND	158
IO351PB6F40	61	IO419PB7F47	7	GND	164
IO352NB6F40	64	Dedicated I/O		GND	170

CQ352	
RTAX4000D Function	Pin Number
GND	176
GND	177
GND	180
GND	186
GND	192
GND	194
GND	198
GND	204
GND	210
GND	216
GND	220
GND	222
GND	226
GND	232
GND	238
GND	244
GND	248
GND	250
GND	256
GND	262
GND	264
GND	265
GND	272
GND	278
GND	284
GND	293
GND	295
GND	302
GND	308
GND	310
GND	316
GND	323
GND	325
GND	334
GND	340

CQ352	
RTAX4000D Function	Pin Number
GND	345
GND	352
PRA	312
PRB	311
PRC	136
PRD	135
TCK	349
TDI	348
TDO	347
TMS	350
TRST	351
VCCA	3
VCCA	44
VCCA	87
VCCA	129
VCCA	175
VCCA	219
VCCA	263
VCCA	305
VCCA	4
VCCA	18
VCCA	34
VCCA	56
VCCA	72
VCCA	85
VCCA	101
VCCA	116
VCCA	131
VCCA	148
VCCA	163
VCCA	179
VCCA	193
VCCA	209
VCCA	231
VCCA	247

CQ352	
RTAX4000D Function	Pin Number
VCCA	261
VCCA	277
VCCA	292
VCCA	307
VCCA	324
VCCA	339
VCCDA	2
VCCDA	16
VCCDA	46
VCCDA	74
VCCDA	90
VCCDA	91
VCCDA	113
VCCDA	114
VCCDA	115
VCCDA	118
VCCDA	120
VCCDA	121
VCCDA	122
VCCDA	130
VCCDA	133
VCCDA	143
VCCDA	144
VCCDA	145
VCCDA	146
VCCDA	150
VCCDA	151
VCCDA	152
VCCDA	174
VCCDA	178
VCCDA	191
VCCDA	221
VCCDA	249
VCCDA	266
VCCDA	268

CQ352	
RTAX4000D Function	Pin Number
VCCDA	289
VCCDA	290
VCCDA	291
VCCDA	294
VCCDA	296
VCCDA	297
VCCDA	298
VCCDA	306
VCCDA	309
VCCDA	319
VCCDA	320
VCCDA	321
VCCDA	322
VCCDA	326
VCCDA	327
VCCDA	328
VCCDA	346
VCCIB0	315
VCCIB0	333
VCCIB0	344
VCCIB1	271
VCCIB1	283
VCCIB1	301
VCCIB2	225
VCCIB2	237
VCCIB2	243
VCCIB2	255
VCCIB3	185
VCCIB3	197
VCCIB3	203
VCCIB3	215
VCCIB4	139
VCCIB4	157
VCCIB4	169
VCCIB5	95

CQ352	
RTAX4000D Function	Pin Number
VCCIB5	107
VCCIB5	125
VCCIB6	50
VCCIB6	62
VCCIB6	68
VCCIB6	80
VCCIB7	10
VCCIB7	22
VCCIB7	28
VCCIB7	40
VPUMP	267

CG624/LG624

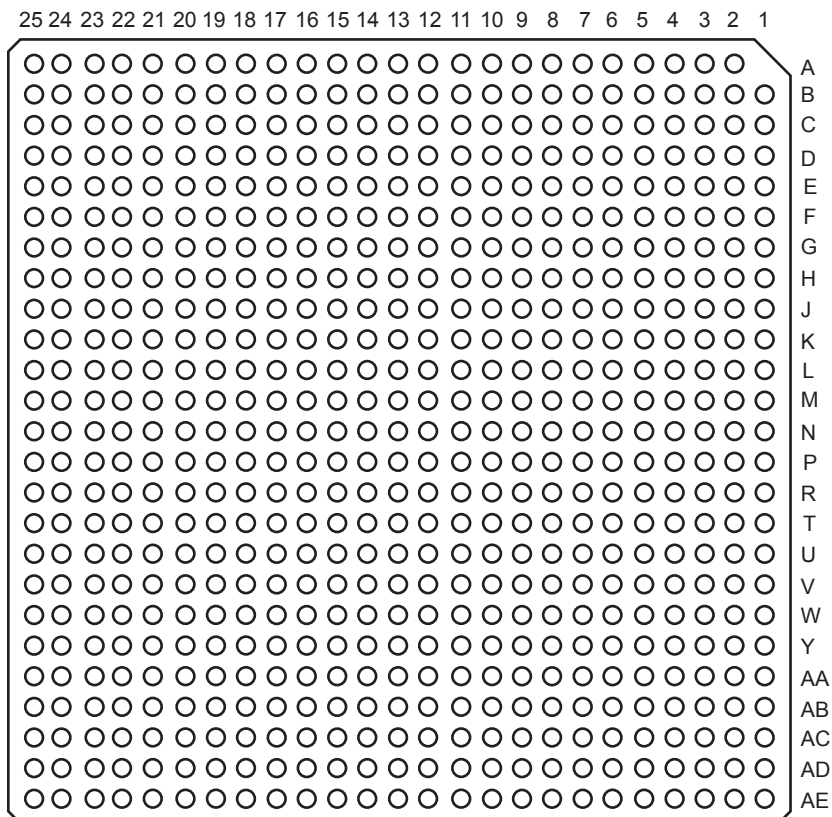

Note:

The 624-pin CCGA pin assignments for RTAX250S/SL, RTAX1000S/SL and RTAX2000S/SL are compatible except for the following pins.

Table 1 • Compatibility Table for the CGA/LGA 624 Package

	RTAX250S/SL	RTAX1000S/SL	RTAX2000S/SL
RTAX250S/SL	NA	A12, AD11, AE17, B15, D13	A12, A14, AA20, AB13, AD11, AD4, AE12, B15, D13, F21, G10
RTAX1000S/SL	A12, AD11, AE17, B15, D13	NA	A14, AA20, AB13, AD4, AE12, F21, G10
RTAX2000S/SL	A12, A14, AA20, AB13, AD11, AD4, AE12, B15, D13, F21, G10	A14, AA20, AB13, AD4, AE12, F21, G10	NA

Where exceptions occur, the smaller density devices have those pins designated as No Connects (NC). Customers are therefore recommended to layout their board targeting the larger density device, in order to preserve interchangeability between the two devices. Note: RTAX4000S is not pin compatible with any of the smaller density devices.

For Package Manufacturing and Environmental information, visit the Resource center at <http://www.microsemi.com/soc/products/solutions/package/docs.aspx>.

CG624/LG624		CG624/LG624		CG624/LG624	
RTAX250S/SL Function	Pin Number	RTAX250S/SL Function	Pin Number	RTAX250S/SL Function	Pin Number
Bank 0		IO21PB1F1	A19	IO37PB2F2	K24
IO00NB0F0	C9	IO22NB1F1	D18	IO38NB2F2	J24
IO00PB0F0	C8	IO22PB1F1	D17	IO38PB2F2	H24
IO01NB0F0	B5	IO23NB1F1	A22	IO39NB2F2	N22
IO01PB0F0	B4	IO23PB1F1	A21	IO39PB2F2	M22
IO02NB0F0	D10	IO24NB1F1	G17	IO40NB2F2	N24
IO02PB0F0	D9	IO24PB1F1	H17	IO40PB2F2	M24
IO03NB0F0	A5	IO25NB1F1	C21	IO41NB2F2	N19
IO03PB0F0	A4	IO25PB1F1	C20	IO41PB2F2	N18
IO04NB0F0	H8	IO26NB1F1	C19	IO42NB2F2	L25
IO04PB0F0	H7	IO26PB1F1	C18	IO42PB2F2	K25
IO05NB0F0	A7	IO27NB1F1	D20	IO43NB2F2	N23
IO05PB0F0	A6	IO27PB1F1	D19	IO43PB2F2	M23
IO06NB0F0	H10	IO14NB1F1/HCLKCN	G15	IO44NB2F2	N25
IO06PB0F0	H9	IO14PB1F1/HCLKCP	G14	IO44PB2F2	M25
IO07NB0F0	B11	IO15NB1F1/HCLKDN	B14	Bank 3	
IO07PB0F0	B10	IO15PB1F1/HCLKDP	B13	IO45NB3F3	R22
IO08NB0F0	J8	Bank 2		IO45PB3F3	P22
IO08PB0F0	J7	IO28NB2F2	J22	IO46NB3F3	R25
IO09NB0F0	A9	IO28PB2F2	H22	IO46PB3F3	P25
IO09PB0F0	B9	IO29NB2F2	L18	IO47NB3F3	R23
IO12NB0F0/HCLKAN	G13	IO29PB2F2	K18	IO47PB3F3	P23
IO12PB0F0/HCLKAP	G12	IO30NB2F2	F23	IO48NB3F3	Y25
IO13NB0F0/HCLKBN	C13	IO30PB2F2	E23	IO48PB3F3	W25
IO13PB0F0/HCLKBP	C12	IO31NB2F2	J21	IO49NB3F3	U24
Bank 1		IO31PB2F2	J20	IO49PB3F3	U23
IO16NB1F1	D14	IO32NB2F2	E25	IO50NB3F3	T24
IO16PB1F1	C14	IO32PB2F2	D25	IO50PB3F3	R24
IO17NB1F1	A16	IO33NB2F2	M19	IO51NB3F3	Y23
IO17PB1F1	A15	IO33PB2F2	M18	IO51PB3F3	AA23
IO18NB1F1	H20	IO34NB2F2	H23	IO52NB3F3	V23
IO18PB1F1	H19	IO34PB2F2	G23	IO52PB3F3	V24
IO19NB1F1	B17	IO35NB2F2	L22	IO53NB3F3	P20
IO19PB1F1	B16	IO35PB2F2	K22	IO53PB3F3	P19
IO20NB1F1	D16	IO36NB2F2	G25	IO54NB3F3	U25
IO20PB1F1	D15	IO36PB2F2	F25	IO54PB3F3	T25
IO21NB1F1	A20	IO37NB2F2	L24	IO55NB3F3	V22

CG624/LG624	
RTAX250S/SL Function	Pin Number
IO55PB3F3	U22
IO56NB3F3	AA24
IO56PB3F3	Y24
IO57NB3F3	V20
IO57PB3F3	U20
IO58NB3F3	AB25
IO58PB3F3	AA25
IO59NB3F3	Y22
IO59PB3F3	Y21
IO60NB3F3	W22
IO60PB3F3	W23
IO61NB3F3	T18
IO61PB3F3	R18
Bank 4	
IO62NB4F4	V19
IO62PB4F4	W19
IO63NB4F4	AE19
IO63PB4F4	AE20
IO64NB4F4	W18
IO64PB4F4	V18
IO65NB4F4	AC20
IO65PB4F4	AC21
IO66NB4F4	AD14
IO66PB4F4	AC14
IO67NB4F4	AD21
IO67PB4F4	AD22
IO68NB4F4	AD15
IO68PB4F4	AD16
IO69NB4F4	AD19
IO69PB4F4	AD20
IO70NB4F4	AB14
IO70PB4F4	AB15
IO71NB4F4	AD17
IO71PB4F4	AD18
IO72NB4F4	V15
IO72PB4F4	V16
IO73NB4F4	AE15

CG624/LG624	
RTAX250S/SL Function	Pin Number
IO73PB4F4	AE16
IO74NB4F4/CLKEN	W14
IO74PB4F4/CLKEP	W15
IO75NB4F4/CLKFN	AC13
IO75PB4F4/CLKFP	AD13
Bank 5	
IO78NB5F5	AE10
IO78PB5F5	AE11
IO79NB5F5	AD9
IO79PB5F5	AD10
IO80NB5F5	V9
IO80PB5F5	V10
IO81NB5F5	AD7
IO81PB5F5	AD8
IO82NB5F5	AB10
IO82PB5F5	AB11
IO83NB5F5	AE6
IO83PB5F5	AE7
IO84NB5F5	AB8
IO84PB5F5	AC8
IO85NB5F5	AE4
IO85PB5F5	AE5
IO86NB5F5	U13
IO86PB5F5	V13
IO87NB5F5	AC5
IO87PB5F5	AC6
IO88NB5F5	Y7
IO88PB5F5	W7
IO89NB5F5	AB7
IO89PB5F5	AC7
IO76NB5F5/CLKGN	W13
IO76PB5F5/CLKGP	Y13
IO77NB5F5/CLKHN	AC12
IO77PB5F5/CLKHP	AD12
Bank 6	
IO90NB6F6	Y3
IO90PB6F6	AA3

CG624/LG624	
RTAX250S/SL Function	Pin Number
IO91NB6F6	U4
IO91PB6F6	V4
IO92NB6F6	AA1
IO92PB6F6	AB1
IO93NB6F6	W2
IO93PB6F6	Y2
IO94NB6F6	V3
IO94PB6F6	W3
IO95NB6F6	R4
IO95PB6F6	T4
IO96NB6F6	W1
IO96PB6F6	Y1
IO97NB6F6	Y5
IO97PB6F6	W5
IO98NB6F6	T2
IO98PB6F6	U2
IO99NB6F6	N3
IO99PB6F6	P3
IO100NB6F6	T1
IO100PB6F6	U1
IO101NB6F6	N4
IO101PB6F6	P4
IO102NB6F6	P2
IO102PB6F6	R2
IO103NB6F6	R8
IO103PB6F6	T8
IO104NB6F6	P1
IO104PB6F6	R1
IO105NB6F6	M2
IO105PB6F6	N2
IO106NB6F6	M1
IO106PB6F6	N1
Bank 7	
IO107NB7F7	H4
IO107PB7F7	J4
IO108NB7F7	K1
IO108PB7F7	L1

CG624/LG624		CG624/LG624		CG624/LG624	
RTAX250S/SL Function	Pin Number	RTAX250S/SL Function	Pin Number	RTAX250S/SL Function	Pin Number
IO109NB7F7	L3	GND	V5	GND	C10
IO109PB7F7	M3	GND	AA10	GND	C16
IO10NB0F0	D12	GND	AA16	GND	C23
IO10PB0F0	D11	GND	AA18	GND	C3
IO110NB7F7	J2	GND	T21	GND	D22
IO110PB7F7	J1	GND	K21	GND	D4
IO111NB7F7	N10	GND	H21	GND	E21
IO111PB7F7	N9	GND	E16	GND	E5
IO112NB7F7	K2	GND	E10	GND	H1
IO112PB7F7	L2	GND	E8	GND	H25
IO113NB7F7	K8	GND	A18	GND	K23
IO113PB7F7	L8	GND	A2	GND	K3
IO114NB7F7	F1	GND	A24	GND	L11
IO114PB7F7	G1	GND	A25	GND	L12
IO115NB7F7	J6	GND	A8	GND	L13
IO115PB7F7	J5	GND	AA21	GND	L14
IO116NB7F7	H3	GND	AA5	GND	L15
IO116PB7F7	H2	GND	AB22	GND	M11
IO117NB7F7	K4	GND	AB4	GND	M12
IO117PB7F7	L4	GND	AC10	GND	M13
IO118NB7F7	E2	GND	AC16	GND	M14
IO118PB7F7	F2	GND	AC23	GND	M15
IO119NB7F7	M9	GND	AC3	GND	N11
IO119PB7F7	M8	GND	AD1	GND	N12
IO11NB0F0	A11	GND	AD2	GND	N13
IO11PB0F0	A10	GND	AD24	GND	N14
IO120NB7F7	D1	GND	AD25	GND	N15
IO120PB7F7	E1	GND	AE1	GND	P11
IO121NB7F7	F3	GND	AE18	GND	P12
IO121PB7F7	E3	GND	AE2	GND	P13
IO122NB7F7	G4	GND	AE24	GND	P14
IO122PB7F7	G3	GND	AE25	GND	P15
IO123NB7F7	H5	GND	AE8	GND	R11
IO123PB7F7	H6	GND	B1	GND	R12
Dedicated I/O		GND	B2	GND	R13
GND	K5	GND	B24	GND	R14
GND	T5	GND	B25	GND	R15

CG624/LG624	
RTAX250S/SL Function	Pin Number
GND	T23
GND	T3
GND	V1
GND	V25
NC	A12
NC	A14
NC	A17
NC	AA11
NC	AA12
NC	AA14
NC	AA17
NC	AA19
NC	AA2
NC	AA20
NC	AA6
NC	AA8
NC	AA9
NC	AB13
NC	AB16
NC	AB17
NC	AB18
NC	AB19
NC	AB2
NC	AB24
NC	AB6
NC	AB9
NC	AC15
NC	AC17
NC	AC18
NC	AC19
NC	AC9
NC	AD11
NC	AD4
NC	AD5
NC	AD6
NC	AE12
NC	AE14

CG624/LG624	
RTAX250S/SL Function	Pin Number
NC	AE17
NC	AE21
NC	AE22
NC	AE9
NC	B12
NC	B15
NC	B18
NC	B19
NC	B20
NC	B21
NC	B22
NC	B6
NC	B7
NC	B8
NC	C11
NC	C17
NC	C7
NC	D13
NC	D2
NC	D24
NC	D7
NC	D8
NC	E11
NC	E12
NC	E14
NC	E15
NC	E17
NC	E18
NC	E24
NC	E7
NC	E9
NC	F10
NC	F11
NC	F12
NC	F14
NC	F15
NC	F16

CG624/LG624	
RTAX250S/SL Function	Pin Number
NC	F17
NC	F18
NC	F19
NC	F20
NC	F21
NC	F24
NC	F7
NC	F8
NC	F9
NC	G10
NC	G11
NC	G16
NC	G18
NC	G19
NC	G2
NC	G20
NC	G21
NC	G22
NC	G24
NC	G6
NC	G7
NC	G8
NC	G9
NC	H11
NC	H12
NC	H13
NC	H14
NC	H15
NC	H16
NC	H18
NC	J12
NC	J13
NC	J14
NC	J18
NC	J19
NC	J23
NC	J25

CG624/LG624		CG624/LG624		CG624/LG624	
RTAX250S/SL Function	Pin Number	RTAX250S/SL Function	Pin Number	RTAX250S/SL Function	Pin Number
NC	J3	NC	R21	NC	W4
NC	K13	NC	R3	NC	W6
NC	K19	NC	R5	NC	W8
NC	K20	NC	R6	NC	W9
NC	K6	NC	R7	NC	Y10
NC	K7	NC	T13	NC	Y11
NC	L19	NC	T19	NC	Y12
NC	L20	NC	T20	NC	Y14
NC	L21	NC	T22	NC	Y15
NC	L23	NC	T6	NC	Y16
NC	L5	NC	T7	NC	Y17
NC	L6	NC	U12	NC	Y18
NC	L7	NC	U14	NC	Y19
NC	M17	NC	U18	NC	Y20
NC	M20	NC	U19	NC	Y6
NC	M21	NC	U21	NC	Y8
NC	M4	NC	U3	NC	Y9
NC	M5	NC	U5	PRA	F13
NC	M6	NC	U6	PRB	A13
NC	M7	NC	U7	PRC	AB12
NC	N16	NC	U8	PRD	AE13
NC	N17	NC	V11	TCK	F5
NC	N20	NC	V12	TDI	C5
NC	N6	NC	V14	TDO	F6
NC	N7	NC	V17	TMS	D6
NC	N8	NC	V2	TRST	E6
NC	P17	NC	V21	VCCA	F4
NC	P18	NC	V6	VCCA	Y4
NC	P21	NC	V7	VCCA	AB20
NC	P24	NC	V8	VCCA	F22
NC	P5	NC	W10	VCCA	J17
NC	P6	NC	W11	VCCA	J9
NC	P7	NC	W12	VCCA	K10
NC	P8	NC	W16	VCCA	K11
NC	P9	NC	W17	VCCA	K15
NC	R19	NC	W20	VCCA	K16
NC	R20	NC	W24	VCCA	L10

CG624/LG624	
RTAX250S/SL Function	Pin Number
VCCA	L16
VCCA	R10
VCCA	R16
VCCA	T10
VCCA	T11
VCCA	T15
VCCA	T16
VCCA	U17
VCCA	U9
VCCDA	G5
VCCDA	N5
VCCDA	AA7
VCCDA	AC11
VCCDA	AA13
VCCDA	AA15
VCCDA	W21
VCCDA	N21
VCCDA	E19
VCCDA	C15
VCCDA	E13
VCCDA	C6
VCCIB0	A3
VCCIB0	B3
VCCIB0	C4
VCCIB0	D5
VCCIB0	J10
VCCIB0	J11
VCCIB0	K12
VCCIB1	A23
VCCIB1	B23
VCCIB1	C22
VCCIB1	D21
VCCIB1	J15
VCCIB1	J16
VCCIB1	K14
VCCIB2	C24
VCCIB2	C25

CG624/LG624	
RTAX250S/SL Function	Pin Number
VCCIB2	D23
VCCIB2	E22
VCCIB2	K17
VCCIB2	L17
VCCIB2	M16
VCCIB3	AA22
VCCIB3	AB23
VCCIB3	AC24
VCCIB3	AC25
VCCIB3	P16
VCCIB3	R17
VCCIB3	T17
VCCIB4	AB21
VCCIB4	AC22
VCCIB4	AD23
VCCIB4	AE23
VCCIB4	T14
VCCIB4	U15
VCCIB4	U16
VCCIB5	AB5
VCCIB5	AC4
VCCIB5	AD3
VCCIB5	AE3
VCCIB5	T12
VCCIB5	U10
VCCIB5	U11
VCCIB6	AA4
VCCIB6	AB3
VCCIB6	AC1
VCCIB6	AC2
VCCIB6	P10
VCCIB6	R9
VCCIB6	T9
VCCIB7	C1
VCCIB7	C2
VCCIB7	D3
VCCIB7	E4

CG624/LG624	
RTAX250S/SL Function	Pin Number
VCCIB7	K9
VCCIB7	L9
VCCIB7	M10
VPUMP	E20

CG624/LG624		CG624/LG624		CG624/LG624	
RTAX1000S/SL Function	Pin Number	RTAX1000S/SL Function	Pin Number	RTAX1000S/SL Function	Pin Number
Bank 0		IO23PB0F2	F11	IO43NB1F4	A16
IO00NB0F0	F8	IO24NB0F2	D7	IO43PB1F4	A15
IO00PB0F0	F7	IO24PB0F2	E7	IO44NB1F4	A20
IO02NB0F0	G7	IO25PB0F2	B12	IO44PB1F4	A19
IO02PB0F0	G6	IO26NB0F2	H11	IO45NB1F4	B17
IO04NB0F0	E9	IO26PB0F2	G11	IO45PB1F4	B16
IO04PB0F0	D8	IO27NB0F2	C11	IO46NB1F4	G17
IO06NB0F0	G9	IO27PB0F2	B8	IO46PB1F4	H17
IO06PB0F0	G8	IO28NB0F2	J13	IO47NB1F4	A17
IO07PB0F0	B6	IO28PB0F2	K13	IO48NB1F4	C19
IO08NB0F0	F10	IO29NB0F2	J8	IO48PB1F4	C18
IO08PB0F0	F9	IO29PB0F2	J7	IO49NB1F4	B20
IO09PB0F0	C7	IO30NB0F2/HCLKAN	G13	IO49PB1F4	B19
IO10NB0F0	H8	IO30PB0F2/HCLKAP	G12	IO50NB1F4	H20
IO10PB0F0	H7	IO31NB0F2/HCLKBN	C13	IO50PB1F4	H19
IO11NB0F0	D10	IO31PB0F2/HCLKBP	C12	IO51NB1F4	A22
IO11PB0F0	D9	Bank 1		IO51PB1F4	A21
IO12NB0F1	B5	IO32NB1F3/HCLKCN	G15	IO52NB1F4	C21
IO12PB0F1	B4	IO32PB1F3/HCLKCP	G14	IO52PB1F4	C20
IO13NB0F1	A7	IO33NB1F3/HCLKDN	B14	IO53NB1F4	B22
IO13PB0F1	A6	IO33PB1F3/HCLKDP	B13	IO53PB1F4	B21
IO14NB0F1	C9	IO34NB1F3	G16	IO54NB1F5	J18
IO14PB0F1	C8	IO34PB1F3	H16	IO54PB1F5	J19
IO15PB0F1	B7	IO35NB1F3	C17	IO55NB1F5	D18
IO16NB0F1	A5	IO35PB1F3	B18	IO55PB1F5	D17
IO16PB0F1	A4	IO36NB1F3	H18	IO56NB1F5	F20
IO17NB0F1	A9	IO36PB1F3	H15	IO56PB1F5	F19
IO17PB0F1	B9	IO37NB1F3	H13	IO58NB1F5	E17
IO18NB0F1	D12	IO38NB1F3	E15	IO58PB1F5	F17
IO18PB0F1	D11	IO38PB1F3	F15	IO60NB1F5	D20
IO20NB0F1	B11	IO39NB1F3	D14	IO60PB1F5	D19
IO20PB0F1	B10	IO39PB1F3	C14	IO62NB1F5	E18
IO21NB0F1	A11	IO40NB1F3	D16	IO62PB1F5	F18
IO21PB0F1	A10	IO40PB1F3	D15	IO63NB1F5	G19
IO22NB0F2	H10	IO41NB1F4	F16	IO63PB1F5	G18
IO22PB0F2	H9	IO42NB1F4	G21	Bank 2	
IO23NB0F2	E11	IO42PB1F4	G20	IO64NB2F6	M17

CG624/LG624		CG624/LG624		CG624/LG624	
RTAX1000S/SL Function	Pin Number	RTAX1000S/SL Function	Pin Number	RTAX1000S/SL Function	Pin Number
IO64PB2F6	G22	IO87NB2F8	L24	IO108NB3F10	R25
IO65NB2F6	J21	IO87PB2F8	K24	IO108PB3F10	P25
IO65PB2F6	J20	IO88NB2F8	G24	IO109NB3F10	U25
IO66NB2F6	L23	IO88PB2F8	F24	IO109PB3F10	T25
IO66PB2F6	K20	IO89NB2F8	J25	IO110NB3F10	U24
IO67NB2F6	F23	IO90NB2F8	G25	IO110PB3F10	U23
IO67PB2F6	E23	IO90PB2F8	F25	IO112NB3F10	T24
IO68NB2F6	L18	IO91NB2F8	L25	IO112PB3F10	R24
IO68PB2F6	K18	IO91PB2F8	K25	IO113NB3F10	Y25
IO70NB2F6	E24	IO92NB2F8	J24	IO113PB3F10	W25
IO70PB2F6	D24	IO92PB2F8	H24	IO114NB3F10	V23
IO71NB2F6	H23	IO93PB2F8	J23	IO114PB3F10	V24
IO71PB2F6	G23	IO94NB2F8	N24	IO116NB3F10	AA24
IO72NB2F6	L19	IO94PB2F8	M24	IO116PB3F10	Y24
IO72PB2F6	K19	IO95NB2F8	N25	IO117NB3F10	AB25
IO74NB2F7	J22	IO95PB2F8	M25	IO117PB3F10	AA25
IO74PB2F7	H22	Bank 3		IO118NB3F11	T20
IO75NB2F7	N23	IO96NB3F9	T18	IO118PB3F11	R21
IO75PB2F7	M23	IO96PB3F9	R18	IO120NB3F11	W22
IO76NB2F7	N17	IO97NB3F9	N20	IO120PB3F11	W23
IO76PB2F7	N16	IO97PB3F9	P24	IO122NB3F11	V22
IO77NB2F7	L22	IO98NB3F9	P20	IO122PB3F11	U22
IO77PB2F7	K22	IO98PB3F9	P19	IO124NB3F11	Y23
IO78NB2F7	M19	IO99NB3F9	P21	IO124PB3F11	AA23
IO78PB2F7	M18	IO100NB3F9	T22	IO126NB3F11	V21
IO79NB2F7	N19	IO100PB3F9	W24	IO126PB3F11	U21
IO79PB2F7	N18	IO101NB3F9	R22	IO128NB3F11	Y22
IO80NB2F7	L21	IO101PB3F9	P22	IO128PB3F11	Y21
IO80PB2F7	L20	IO102NB3F9	U19	Bank 4	
IO82NB2F7	P18	IO102PB3F9	T19	IO129NB4F12	W20
IO82PB2F7	P17	IO104NB3F9	V20	IO129PB4F12	Y20
IO83NB2F7	N22	IO104PB3F9	U20	IO131NB4F12	V19
IO83PB2F7	M22	IO105NB3F9	R23	IO131PB4F12	W19
IO84NB2F7	M20	IO105PB3F9	P23	IO133NB4F12	Y18
IO84PB2F7	M21	IO106NB3F9	R19	IO133PB4F12	Y19
IO86NB2F8	E25	IO106PB3F9	R20	IO135NB4F12	W18
IO86PB2F8	D25	IO107NB3F10	AB24	IO135PB4F12	V18

CG624/LG624		CG624/LG624		CG624/LG624	
RTAX1000S/SL Function	Pin Number	RTAX1000S/SL Function	Pin Number	RTAX1000S/SL Function	Pin Number
IO137NB4F12	Y17	IO157PB4F14	AC18	IO178PB5F16	W6
IO137PB4F12	AA17	IO158NB4F14	AC15	IO179NB5F16	Y10
IO138NB4F12	AB19	IO158PB4F14	AC19	IO179PB5F16	W10
IO138PB4F12	AB18	IO159NB4F14/CLKEN	W14	IO180NB5F16	Y7
IO139NB4F13	AA19	IO159PB4F14/CLKEP	W15	IO180PB5F16	W7
IO139PB4F13	U18	IO160NB4F14/CLKFN	AC13	IO181NB5F17	AD9
IO140NB4F13	AC20	IO160PB4F14/CLKFP	AD13	IO181PB5F17	AD10
IO140PB4F13	AC21	Bank 5		IO182NB5F17	AE10
IO141NB4F13	AD17	IO161NB5F15/CLKGN	W13	IO182PB5F17	AE11
IO141PB4F13	AD18	IO161PB5F15/CLKGP	Y13	IO183NB5F17	AD7
IO142NB4F13	AD21	IO162NB5F15/CLKHN	AC12	IO183PB5F17	AD8
IO142PB4F13	AD22	IO162PB5F15/CLKHP	AD12	IO184NB5F17	AB9
IO143NB4F13	AB17	IO163NB5F15	V9	IO185NB5F17	AE6
IO143PB4F13	AC17	IO163PB5F15	V10	IO185PB5F17	AE7
IO144PB4F13	AE22	IO164NB5F15	V11	IO186NB5F17	AE4
IO145NB4F13	AE15	IO164PB5F15	T13	IO186PB5F17	AE5
IO145PB4F13	AE16	IO165NB5F15	U13	IO187NB5F17	AA9
IO146NB4F13	AD19	IO165PB5F15	V13	IO187PB5F17	Y9
IO146PB4F13	AD20	IO167NB5F15	W11	IO188NB5F17	U8
IO147NB4F13	AD15	IO167PB5F15	W12	IO189NB5F17	AD5
IO147PB4F13	AD16	IO168NB5F15	AB6	IO189PB5F17	AD6
IO148PB4F13	AE21	IO168PB5F15	AA6	IO191NB5F17	AC5
IO149NB4F13	AD14	IO169NB5F15	V8	IO191PB5F17	AC6
IO149PB4F13	AC14	IO169PB5F15	V7	IO192NB5F17	AB7
IO150NB4F13	AE19	IO171NB5F16	W8	IO192PB5F17	AC7
IO150PB4F13	AE20	IO171PB5F16	W9	Bank 6	
IO151NB4F13	V17	IO172NB5F16	AB8	IO193NB6F18	U6
IO151PB4F13	W17	IO172PB5F16	AC8	IO193PB6F18	U5
IO152NB4F14	AB16	IO173NB5F16	AA11	IO194NB6F18	Y3
IO152PB4F14	W16	IO173PB5F16	Y11	IO194PB6F18	AA3
IO153NB4F14	Y15	IO174NB5F16	AB10	IO195NB6F18	V6
IO153PB4F14	Y16	IO174PB5F16	AB11	IO195PB6F18	W4
IO155NB4F14	V15	IO175NB5F16	AC9	IO197NB6F18	R5
IO155PB4F14	V16	IO175PB5F16	AE9	IO197PB6F18	U3
IO156NB4F14	AB14	IO177NB5F16	AA8	IO198NB6F18	P6
IO156PB4F14	AB15	IO177PB5F16	Y8	IO199NB6F18	Y5
IO157NB4F14	AE14	IO178NB5F16	Y6	IO199PB6F18	W5

CG624/LG624		CG624/LG624		CG624/LG624	
RTAX1000S/SL Function	Pin Number	RTAX1000S/SL Function	Pin Number	RTAX1000S/SL Function	Pin Number
IO200NB6F18	V3	IO221PB6F20	P4	IO244NB7F22	P9
IO200PB6F18	W3	IO223NB6F20	M2	IO244PB7F22	N6
IO201NB6F18	T7	IO223PB6F20	N2	IO245NB7F22	K8
IO201PB6F18	U7	IO224NB6F20	N3	IO245PB7F22	L8
IO202NB6F18	V2	IO224PB6F20	P3	IO246NB7F22	F3
IO203NB6F19	W2	Bank 7		IO246PB7F22	E3
IO203PB6F19	Y2	IO225NB7F21	J2	IO247NB7F23	K7
IO204NB6F19	AA1	IO225PB7F21	J1	IO247PB7F23	K6
IO204PB6F19	AB1	IO226PB7F21	G2	IO248NB7F23	D2
IO205NB6F19	R6	IO227NB7F21	H3	IO249NB7F23	G4
IO205PB6F19	T6	IO227PB7F21	H2	IO249PB7F23	G3
IO206NB6F19	W1	IO229NB7F21	K2	IO251NB7F23	N10
IO206PB6F19	Y1	IO229PB7F21	L2	IO251PB7F23	N9
IO207NB6F19	T2	IO230NB7F21	K1	IO253NB7F23	H4
IO207PB6F19	U2	IO230PB7F21	L1	IO253PB7F23	J4
IO208NB6F19	T1	IO231NB7F21	E2	IO255NB7F23	J6
IO208PB6F19	U1	IO231PB7F21	F2	IO255PB7F23	J5
IO209NB6F19	AA2	IO232NB7F21	F1	IO257NB7F23	H5
IO209PB6F19	AB2	IO232PB7F21	G1	IO257PB7F23	H6
IO210NB6F19	P5	IO233NB7F21	L3	Dedicated I/O	
IO211NB6F19	M1	IO233PB7F21	M3	GND	K5
IO211PB6F19	N1	IO234NB7F21	D1	GND	A18
IO212NB6F19	P1	IO234PB7F21	E1	GND	A2
IO212PB6F19	R1	IO235NB7F21	K4	GND	A24
IO213NB6F19	R8	IO235PB7F21	L4	GND	A25
IO213PB6F19	T8	IO236NB7F22	M6	GND	A8
IO215NB6F20	U4	IO237NB7F22	N8	GND	AA10
IO215PB6F20	V4	IO237PB7F22	N7	GND	AA16
IO216NB6F20	P8	IO238NB7F22	M5	GND	AA18
IO216PB6F20	R3	IO239NB7F22	L6	GND	AA21
IO217NB6F20	P7	IO239PB7F22	L5	GND	AA5
IO217PB6F20	R7	IO240NB7F22	M4	GND	AB22
IO219NB6F20	R4	IO241NB7F22	L7	GND	AB4
IO219PB6F20	T4	IO241PB7F22	M7	GND	AC10
IO220NB6F20	P2	IO242NB7F22	J3	GND	AC16
IO220PB6F20	R2	IO243NB7F22	M9	GND	AC23
IO221NB6F20	N4	IO243PB7F22	M8	GND	AC3

CG624/LG624		CG624/LG624		CG624/LG624	
RTAX1000S/SL Function	Pin Number	RTAX1000S/SL Function	Pin Number	RTAX1000S/SL Function	Pin Number
GND	AD1	GND	M12	NC	F21
GND	AD2	GND	M13	NC	G10
GND	AD24	GND	M14	NC	H12
GND	AD25	GND	M15	NC	H14
GND	AE1	GND	N11	NC	J12
GND	AE18	GND	N12	NC	J14
GND	AE2	GND	N13	NC	U12
GND	AE24	GND	N14	NC	U14
GND	AE25	GND	N15	NC	V12
GND	AE8	GND	P11	NC	V14
GND	B1	GND	P12	NC	Y12
GND	B2	GND	P13	NC	Y14
GND	B24	GND	P14	PRA	F13
GND	B25	GND	P15	PRB	A13
GND	C10	GND	R11	PRC	AB12
GND	C16	GND	R12	PRD	AE13
GND	C23	GND	R13	TCK	F5
GND	C3	GND	R14	TDI	C5
GND	D22	GND	R15	TDO	F6
GND	D4	GND	T21	TMS	D6
GND	E10	GND	T23	TRST	E6
GND	E16	GND	T3	VCCA	AB20
GND	E21	GND	T5	VCCA	F22
GND	E5	GND	V1	VCCA	F4
GND	E8	GND	V25	VCCA	J17
GND	H1	GND	V5	VCCA	J9
GND	H21	NC	A14	VCCA	K10
GND	H25	NC	AA12	VCCA	K11
GND	K21	NC	AA14	VCCA	K15
GND	K23	NC	AA20	VCCA	K16
GND	K3	NC	AB13	VCCA	L10
GND	L11	NC	AD4	VCCA	L16
GND	L12	NC	AE12	VCCA	R10
GND	L13	NC	E12	VCCA	R16
GND	L14	NC	E14	VCCA	T10
GND	L15	NC	F12	VCCA	T11
GND	M11	NC	F14	VCCA	T15

CG624/LG624	
RTAX1000S/SL Function	Pin Number
VCCA	T16
VCCA	U17
VCCA	U9
VCCA	Y4
VCCDA	A12
VCCDA	AA13
VCCDA	AA15
VCCDA	AA7
VCCDA	AC11
VCCDA	AD11
VCCDA	AE17
VCCDA	B15
VCCDA	C15
VCCDA	C6
VCCDA	D13
VCCDA	E13
VCCDA	E19
VCCDA	G5
VCCDA	N21
VCCDA	N5
VCCDA	W21
VCCIB0	A3
VCCIB0	B3
VCCIB0	C4
VCCIB0	D5
VCCIB0	J10
VCCIB0	J11
VCCIB0	K12
VCCIB1	A23
VCCIB1	B23
VCCIB1	C22
VCCIB1	D21
VCCIB1	J15
VCCIB1	J16
VCCIB1	K14
VCCIB2	C24
VCCIB2	C25

CG624/LG624	
RTAX1000S/SL Function	Pin Number
VCCIB2	D23
VCCIB2	E22
VCCIB2	K17
VCCIB2	L17
VCCIB2	M16
VCCIB3	AA22
VCCIB3	AB23
VCCIB3	AC24
VCCIB3	AC25
VCCIB3	P16
VCCIB3	R17
VCCIB3	T17
VCCIB4	AB21
VCCIB4	AC22
VCCIB4	AD23
VCCIB4	AE23
VCCIB4	T14
VCCIB4	U15
VCCIB4	U16
VCCIB5	AB5
VCCIB5	AC4
VCCIB5	AD3
VCCIB5	AE3
VCCIB5	T12
VCCIB5	U10
VCCIB5	U11
VCCIB6	AA4
VCCIB6	AB3
VCCIB6	AC1
VCCIB6	AC2
VCCIB6	P10
VCCIB6	R9
VCCIB6	T9
VCCIB7	C1
VCCIB7	C2
VCCIB7	D3
VCCIB7	E4

CG624/LG624	
RTAX1000S/SL Function	Pin Number
VCCIB7	K9
VCCIB7	L9
VCCIB7	M10
VPUMP	E20

CG624/LG624		CG624/LG624		CG624/LG624	
RTAX2000S/SL Function	Pin Number	RTAX2000S/SL Function	Pin Number	RTAX2000S/SL Function	Pin Number
Bank 0		IO30PB0F2	B10	IO58PB1F5	A21
IO00NB0F0	D7	IO31NB0F2	E11	IO59NB1F5	F16
IO00PB0F0	E7	IO31PB0F2	F11	IO61NB1F5	G17
IO01NB0F0	G7	IO33NB0F2	D12	IO61PB1F5	H17
IO01PB0F0	G6	IO33PB0F2	D11	IO62NB1F5	B17
IO02NB0F0	B5	IO34NB0F3	A11	IO62PB1F5	B16
IO02PB0F0	B4	IO34PB0F3	A10	IO63NB1F5	H18
IO04PB0F0	C7	IO37NB0F3	J13	IO65NB1F6	C17
IO05NB0F0	F8	IO37PB0F3	K13	IO66PB1F6	B18
IO05PB0F0	F7	IO38NB0F3	H11	IO67NB1F6	J18
IO06NB0F0	H8	IO38PB0F3	G11	IO67PB1F6	J19
IO06PB0F0	H7	IO40PB0F3	B12	IO68NB1F6	B20
IO11NB0F0	J8	IO41NB0F3/HCLKAN	G13	IO68PB1F6	B19
IO11PB0F0	J7	IO41PB0F3/HCLKAP	G12	IO69NB1F6	E17
IO12PB0F1	B6	IO42NB0F3/HCLKBN	C13	IO69PB1F6	F17
IO13NB0F1	E9	IO42PB0F3/HCLKBP	C12	IO70NB1F6	B22
IO13PB0F1	D8	Bank 1		IO70PB1F6	B21
IO15NB0F1	C9	IO43NB1F4/HCLKCN	G15	IO71PB1F6	G18
IO15PB0F1	C8	IO43PB1F4/HCLKCP	G14	IO73NB1F6	G19
IO16NB0F1	A5	IO44NB1F4/HCLKDN	B14	IO74NB1F6	C19
IO16PB0F1	A4	IO44PB1F4/HCLKDP	B13	IO74PB1F6	C18
IO17NB0F1	D10	IO45NB1F4	H13	IO75NB1F6	D18
IO17PB0F1	D9	IO47NB1F4	D14	IO75PB1F6	D17
IO18NB0F1	A7	IO47PB1F4	C14	IO76NB1F7	C21
IO18PB0F1	A6	IO48NB1F4	A16	IO76PB1F7	C20
IO19NB0F1	G9	IO48PB1F4	A15	IO79NB1F7	H20
IO19PB0F1	G8	IO49PB1F4	H15	IO79PB1F7	H19
IO20PB0F1	B7	IO51NB1F4	E15	IO80NB1F7	E18
IO23NB0F2	F10	IO51PB1F4	F15	IO80PB1F7	F18
IO23PB0F2	F9	IO52NB1F4	A17	IO81NB1F7	G21
IO26NB0F2	C11	IO55NB1F5	G16	IO81PB1F7	G20
IO26PB0F2	B8	IO55PB1F5	H16	IO82NB1F7	F20
IO27NB0F2	H10	IO56NB1F5	A20	IO82PB1F7	F19
IO27PB0F2	H9	IO56PB1F5	A19	IO85NB1F7	D20
IO28NB0F2	A9	IO57NB1F5	D16	IO85PB1F7	D19
IO28PB0F2	B9	IO57PB1F5	D15	Bank 2	
IO30NB0F2	B11	IO58NB1F5	A22	IO86NB2F8	F23

CG624/LG624		CG624/LG624		CG624/LG624	
RTAX2000S/SL Function	Pin Number	RTAX2000S/SL Function	Pin Number	RTAX2000S/SL Function	Pin Number
IO86PB2F8	E23	IO115PB2F10	M21	IO148PB3F13	T25
IO87NB2F8	H23	IO117NB2F10	N19	IO149NB3F13	T22
IO87PB2F8	G23	IO117PB2F10	N18	IO153NB3F14	U19
IO88NB2F8	E24	IO118NB2F11	J25	IO153PB3F14	T19
IO88PB2F8	D24	IO121NB2F11	N24	IO154NB3F14	Y25
IO89NB2F8	M17	IO121PB2F11	M24	IO154PB3F14	W25
IO89PB2F8	G22	IO122NB2F11	L25	IO157NB3F14	V20
IO91NB2F8	J22	IO122PB2F11	K25	IO157PB3F14	U20
IO91PB2F8	H22	IO123NB2F11	N22	IO158NB3F14	AB25
IO92NB2F8	L18	IO123PB2F11	M22	IO158PB3F14	AA25
IO92PB2F8	K18	IO124NB2F11	N23	IO160PB3F14	W24
IO96NB2F9	G24	IO124PB2F11	M23	IO161NB3F15	U24
IO96PB2F9	F24	IO127NB2F11	P18	IO161PB3F15	U23
IO97NB2F9	J21	IO127PB2F11	P17	IO162NB3F15	AA24
IO97PB2F9	J20	IO128NB2F11	N25	IO162PB3F15	Y24
IO98PB2F9	J23	IO128PB2F11	M25	IO163NB3F15	V22
IO99NB2F9	L19	Bank 3		IO163PB3F15	U22
IO99PB2F9	K19	IO129NB3F12	N20	IO164NB3F15	V23
IO100NB2F9	E25	IO130PB3F12	P24	IO164PB3F15	V24
IO100PB2F9	D25	IO131NB3F12	P21	IO166NB3F15	AB24
IO103PB2F9	K20	IO133NB3F12	P20	IO167NB3F15	V21
IO105NB2F9	M19	IO133PB3F12	P19	IO167PB3F15	U21
IO105PB2F9	M18	IO138NB3F12	R23	IO168NB3F15	Y23
IO106NB2F9	J24	IO138PB3F12	P23	IO168PB3F15	AA23
IO106PB2F9	H24	IO139NB3F13	R22	IO169NB3F15	W22
IO107NB2F10	L23	IO139PB3F13	P22	IO169PB3F15	W23
IO107PB2F10	N16	IO141NB3F13	R19	IO170NB3F15	Y22
IO109NB2F10	L22	IO142NB3F13	R25	IO170PB3F15	Y21
IO109PB2F10	K22	IO142PB3F13	P25	Bank 4	
IO110NB2F10	G25	IO143PB3F13	R21	IO171NB4F16	AC20
IO110PB2F10	F25	IO145NB3F13	T18	IO171PB4F16	AC21
IO111NB2F10	L21	IO145PB3F13	R18	IO172NB4F16	W20
IO111PB2F10	L20	IO146NB3F13	T24	IO172PB4F16	Y20
IO112NB2F10	L24	IO146PB3F13	R24	IO173NB4F16	AD21
IO112PB2F10	K24	IO147NB3F13	T20	IO173PB4F16	AD22
IO113NB2F10	N17	IO147PB3F13	R20	IO174NB4F16	AA19
IO115NB2F10	M20	IO148NB3F13	U25	IO176NB4F16	Y18

CG624/LG624		CG624/LG624		CG624/LG624	
RTAX2000S/SL Function	Pin Number	RTAX2000S/SL Function	Pin Number	RTAX2000S/SL Function	Pin Number
IO176PB4F16	Y19	IO210PB4F19	V16	IO238PB5F22	W9
IO177NB4F16	AB19	IO211NB4F19	AD14	IO239NB5F22	AE4
IO177PB4F16	AB18	IO211PB4F19	AC14	IO239PB5F22	AE5
IO182NB4F17	V19	IO212NB4F19/CLKEN	W14	IO240NB5F22	AB9
IO182PB4F17	W19	IO212PB4F19/CLKEP	W15	IO242NB5F22	AA9
IO183PB4F17	AC19	IO213NB4F19/CLKFN	AC13	IO242PB5F22	Y9
IO184NB4F17	AB17	IO213PB4F19/CLKFP	AD13	IO243NB5F22	AD5
IO184PB4F17	AC17	Bank 5		IO243PB5F22	AD6
IO185NB4F17	AD19	IO214NB5F20/CLKGN	W13	IO244NB5F22	U8
IO185PB4F17	AD20	IO214PB5F20/CLKGP	Y13	IO246NB5F23	AB8
IO187PB4F17	AC18	IO215NB5F20/CLKHN	AC12	IO246PB5F23	AC8
IO188NB4F17	Y17	IO215PB5F20/CLKHP	AD12	IO247NB5F23	AB7
IO188PB4F17	AA17	IO216NB5F20	U13	IO247PB5F23	AC7
IO189PB4F17	AE22	IO216PB5F20	V13	IO250NB5F23	AA8
IO191NB4F17	W18	IO217NB5F20	AE10	IO250PB5F23	Y8
IO191PB4F17	V18	IO217PB5F20	AE11	IO251NB5F23	V8
IO192PB4F17	U18	IO218NB5F20	W11	IO251PB5F23	V7
IO195PB4F18	AE21	IO218PB5F20	W12	IO252NB5F23	Y7
IO196NB4F18	AB16	IO222NB5F20	AA11	IO252PB5F23	W7
IO197NB4F18	AD17	IO222PB5F20	Y11	IO253NB5F23	AC5
IO197PB4F18	AD18	IO223PB5F21	AE9	IO253PB5F23	AC6
IO198NB4F18	V17	IO225NB5F21	AE6	IO254NB5F23	Y6
IO198PB4F18	W17	IO225PB5F21	AE7	IO254PB5F23	W6
IO199NB4F18	AE19	IO226NB5F21	Y10	IO256NB5F23	AB6
IO199PB4F18	AE20	IO226PB5F21	W10	IO256PB5F23	AA6
IO200NB4F18	AC15	IO227PB5F21	T13	Bank 6	
IO201NB4F18	AD15	IO228NB5F21	AB10	IO257NB6F24	Y3
IO201PB4F18	AD16	IO228PB5F21	AB11	IO257PB6F24	AA3
IO202NB4F18	Y15	IO229NB5F21	AD9	IO258NB6F24	V3
IO202PB4F18	Y16	IO229PB5F21	AD10	IO258PB6F24	W3
IO206NB4F19	AB14	IO230NB5F21	V11	IO259NB6F24	AA2
IO206PB4F19	AB15	IO233NB5F21	AD7	IO259PB6F24	AB2
IO207NB4F19	AE15	IO233PB5F21	AD8	IO260NB6F24	V6
IO207PB4F19	AE16	IO234NB5F21	V9	IO260PB6F24	W4
IO208PB4F19	W16	IO234PB5F21	V10	IO262NB6F24	U4
IO209NB4F19	AE14	IO236NB5F22	AC9	IO262PB6F24	V4
IO210NB4F19	V15	IO238NB5F22	W8	IO263NB6F24	Y5

CG624/LG624		CG624/LG624		CG624/LG624	
RTAX2000S/SL Function	Pin Number	RTAX2000S/SL Function	Pin Number	RTAX2000S/SL Function	Pin Number
IO263PB6F24	W5	IO296PB6F27	P3	IO329PB7F30	E1
IO268NB6F25	U6	IO298NB6F27	N4	IO331PB7F30	G2
IO268PB6F25	U5	IO298PB6F27	P4	IO332NB7F31	H3
IO269PB6F25	U3	IO299NB6F27	M2	IO332PB7F31	H2
IO272NB6F25	T2	IO299PB6F27	N2	IO333NB7F31	E2
IO272PB6F25	U2	Bank 7		IO333PB7F31	F2
IO273NB6F25	W2	IO300NB7F28	P9	IO334NB7F31	H4
IO273PB6F25	Y2	IO300PB7F28	N6	IO334PB7F31	J4
IO274NB6F25	R6	IO302NB7F28	M6	IO335NB7F31	H5
IO274PB6F25	T6	IO304NB7F28	N8	IO335PB7F31	H6
IO275NB6F25	T7	IO304PB7F28	N7	IO337NB7F31	D2
IO275PB6F25	U7	IO308NB7F28	M4	IO338NB7F31	J6
IO277NB6F25	V2	IO309NB7F28	L3	IO338PB7F31	J5
IO278NB6F26	R4	IO309PB7F28	M3	IO339NB7F31	F3
IO278PB6F26	T4	IO310NB7F29	N10	IO339PB7F31	E3
IO279PB6F26	R3	IO310PB7F29	N9	IO340NB7F31	G4
IO280NB6F26	R5	IO311NB7F29	K1	IO340PB7F31	G3
IO281NB6F26	AA1	IO311PB7F29	L1	IO341NB7F31	K8
IO281PB6F26	AB1	IO313NB7F29	M5	IO341PB7F31	L8
IO284NB6F26	R8	IO316NB7F29	L6	Dedicated I/O	
IO284PB6F26	T8	IO316PB7F29	L5	GND	K5
IO285NB6F26	W1	IO317NB7F29	K2	GND	A18
IO285PB6F26	Y1	IO317PB7F29	L2	GND	A2
IO286NB6F26	P2	IO318NB7F29	K4	GND	A24
IO286PB6F26	R2	IO318PB7F29	L4	GND	A25
IO287NB6F26	T1	IO320NB7F29	J3	GND	A8
IO287PB6F26	U1	IO321NB7F30	J2	GND	AA10
IO288NB6F26	P5	IO321PB7F30	J1	GND	AA16
IO290NB6F27	P6	IO323NB7F30	L7	GND	AA18
IO291NB6F27	P1	IO323PB7F30	M7	GND	AA21
IO291PB6F27	R1	IO324NB7F30	M9	GND	AA5
IO292NB6F27	P7	IO324PB7F30	M8	GND	AB22
IO292PB6F27	R7	IO327NB7F30	F1	GND	AB4
IO293NB6F27	M1	IO327PB7F30	G1	GND	AC10
IO293PB6F27	N1	IO328NB7F30	K7	GND	AC16
IO294NB6F27	P8	IO328PB7F30	K6	GND	AC23
IO296NB6F27	N3	IO329NB7F30	D1	GND	AC3

CG624/LG624		CG624/LG624		CG624/LG624	
RTAX2000S/SL Function	Pin Number	RTAX2000S/SL Function	Pin Number	RTAX2000S/SL Function	Pin Number
GND	AD1	GND	M12	NC	U14
GND	AD2	GND	M13	NC	V12
GND	AD24	GND	M14	NC	V14
GND	AD25	GND	M15	NC	Y12
GND	AE1	GND	N11	NC	Y14
GND	AE18	GND	N12	PRA	F13
GND	AE2	GND	N13	PRB	A13
GND	AE24	GND	N14	PRC	AB12
GND	AE25	GND	N15	PRD	AE13
GND	AE8	GND	P11	TCK	F5
GND	B1	GND	P12	TDI	C5
GND	B2	GND	P13	TDO	F6
GND	B24	GND	P14	TMS	D6
GND	B25	GND	P15	TRST	E6
GND	C10	GND	R11	VCCA	AB20
GND	C16	GND	R12	VCCA	F22
GND	C23	GND	R13	VCCA	F4
GND	C3	GND	R14	VCCA	J17
GND	D22	GND	R15	VCCA	J9
GND	D4	GND	T21	VCCA	K10
GND	E10	GND	T23	VCCA	K11
GND	E16	GND	T3	VCCA	K15
GND	E21	GND	T5	VCCA	K16
GND	E5	GND	V1	VCCA	L10
GND	E8	GND	V25	VCCA	L16
GND	H1	GND	V5	VCCA	R10
GND	H21	NC	AA12	VCCA	R16
GND	H25	NC	AA14	VCCA	T10
GND	K21	NC	E12	VCCA	T11
GND	K23	NC	E14	VCCA	T15
GND	K3	NC	F12	VCCA	T16
GND	L11	NC	F14	VCCA	U17
GND	L12	NC	H12	VCCA	U9
GND	L13	NC	H14	VCCA	Y4
GND	L14	NC	J12	VCCDA	A12
GND	L15	NC	J14	VCCDA	A14
GND	M11	NC	U12	VCCDA	AA13

CG624/LG624	
RTAX2000S/SL Function	Pin Number
VCCDA	AA15
VCCDA	AA20
VCCDA	AA7
VCCDA	AB13
VCCDA	AC11
VCCDA	AD11
VCCDA	AD4
VCCDA	AE12
VCCDA	AE17
VCCDA	B15
VCCDA	C15
VCCDA	C6
VCCDA	D13
VCCDA	E13
VCCDA	E19
VCCDA	F21
VCCDA	G10
VCCDA	G5
VCCDA	N21
VCCDA	N5
VCCDA	W21
VCCIB0	A3
VCCIB0	B3
VCCIB0	C4
VCCIB0	D5
VCCIB0	J10
VCCIB0	J11
VCCIB0	K12
VCCIB1	A23
VCCIB1	B23
VCCIB1	C22
VCCIB1	D21
VCCIB1	J15
VCCIB1	J16
VCCIB1	K14
VCCIB2	C24
VCCIB2	C25

CG624/LG624	
RTAX2000S/SL Function	Pin Number
VCCIB2	D23
VCCIB2	E22
VCCIB2	K17
VCCIB2	L17
VCCIB2	M16
VCCIB3	AA22
VCCIB3	AB23
VCCIB3	AC24
VCCIB3	AC25
VCCIB3	P16
VCCIB3	R17
VCCIB3	T17
VCCIB4	AB21
VCCIB4	AC22
VCCIB4	AD23
VCCIB4	AE23
VCCIB4	T14
VCCIB4	U15
VCCIB4	U16
VCCIB5	AB5
VCCIB5	AC4
VCCIB5	AD3
VCCIB5	AE3
VCCIB5	T12
VCCIB5	U10
VCCIB5	U11
VCCIB6	AA4
VCCIB6	AB3
VCCIB6	AC1
VCCIB6	AC2
VCCIB6	P10
VCCIB6	R9
VCCIB6	T9
VCCIB7	C1
VCCIB7	C2
VCCIB7	D3
VCCIB7	E4

CG624/LG624	
RTAX2000S/SL Function	Pin Number
VCCIB7	K9
VCCIB7	L9
VCCIB7	M10
VPUMP	E20

CG1152/LG1152

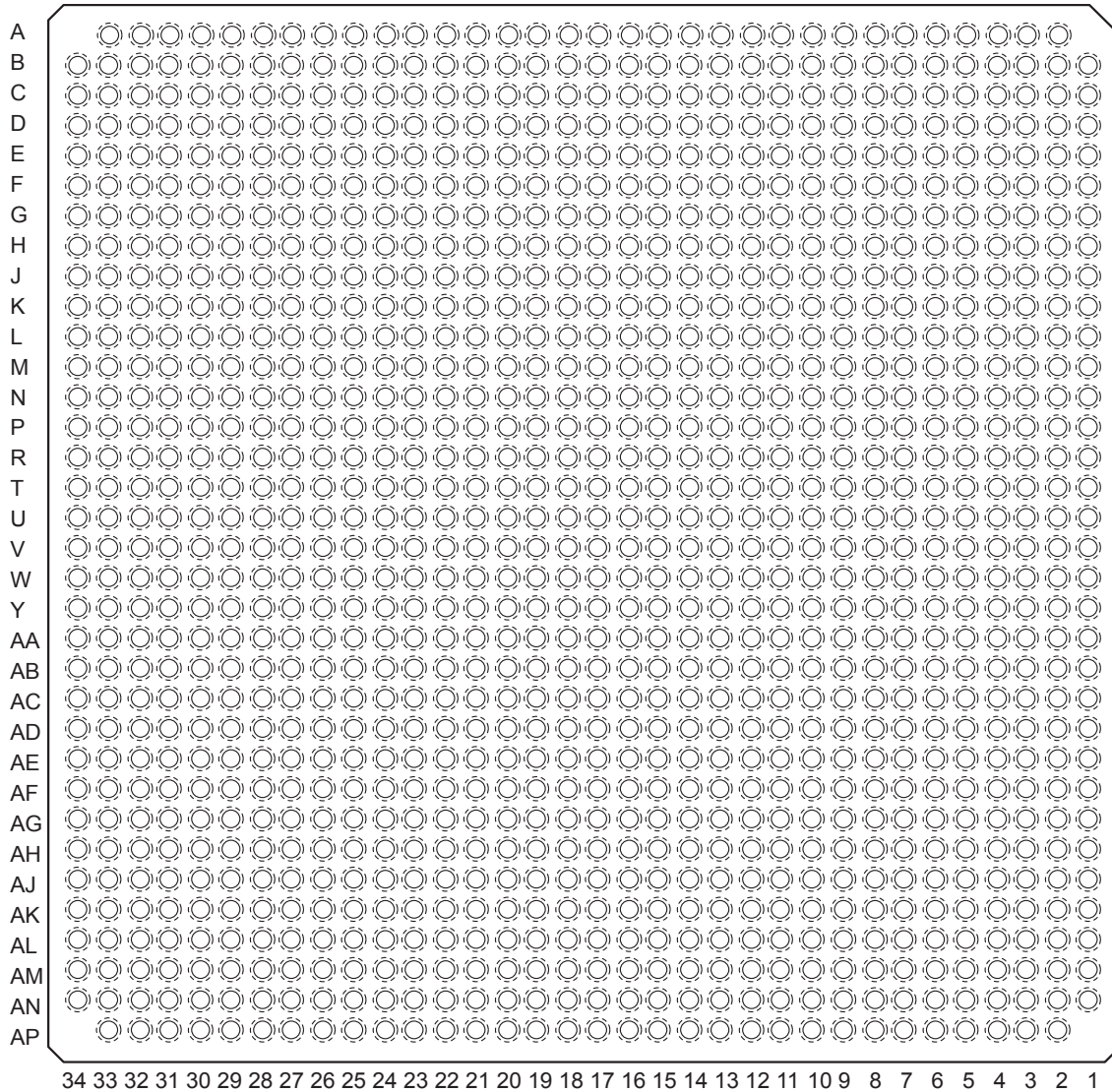

Note

For Package Manufacturing and Environmental information, visit the Resource center at <http://www.microsemi.com/soc/products/solutions/package/docs.aspx>.

CG1152/LG1152	
RTAX2000S/SL Function	Pin Number
Bank 0	
IO00NB0F0	D6
IO00PB0F0	C6
IO01NB0F0	H10
IO01PB0F0	H9
IO02NB0F0	F8
IO02PB0F0	G8
IO03NB0F0	A6
IO03PB0F0	B6
IO04NB0F0	C7
IO04PB0F0	D7
IO05NB0F0	K10
IO05PB0F0	J10
IO06NB0F0	F9
IO06PB0F0	G9
IO07NB0F0	F10
IO07PB0F0	G10
IO08NB0F0	E9
IO08PB0F0	E8
IO09NB0F0	J11
IO09PB0F0	K11
IO10NB0F0	C8
IO10PB0F0	D8
IO11NB0F0	K12
IO11PB0F0	J12
IO12NB0F1	G11
IO12PB0F1	H11
IO13NB0F1	G12
IO13PB0F1	H12
IO14NB0F1	A7
IO14PB0F1	B7
IO15NB0F1	H13
IO15PB0F1	J13
IO16NB0F1	C9
IO16PB0F1	D9
IO17NB0F1	F12
IO17PB0F1	F11

CG1152/LG1152	
RTAX2000S/SL Function	Pin Number
IO18NB0F1	E11
IO18PB0F1	E10
IO19NB0F1	F13
IO19PB0F1	G13
IO20NB0F1	A10
IO20PB0F1	A9
IO21NB0F1	K14
IO21PB0F1	K13
IO22NB0F2	B11
IO22PB0F2	B10
IO23NB0F2	C12
IO23PB0F2	C11
IO24NB0F2	A12
IO24PB0F2	A11
IO25NB0F2	H14
IO25PB0F2	J14
IO26NB0F2	D13
IO26PB0F2	D12
IO27NB0F2	F14
IO27PB0F2	G14
IO28NB0F2	E14
IO28PB0F2	E13
IO29NB0F2	B13
IO29PB0F2	B12
IO30NB0F2	C14
IO30PB0F2	C13
IO31NB0F2	H15
IO31PB0F2	J15
IO32NB0F2	A14
IO32PB0F2	B14
IO33NB0F2	K15
IO33PB0F2	L15
IO34NB0F3	D15
IO34PB0F3	D14
IO35NB0F3	A15
IO35PB0F3	B15
IO36NB0F3	B16

CG1152/LG1152	
RTAX2000S/SL Function	Pin Number
IO36PB0F3	A16
IO37NB0F3	G16
IO37PB0F3	G15
IO38NB0F3	D16
IO38PB0F3	C16
IO39NB0F3	K16
IO39PB0F3	L16
IO40NB0F3	D17
IO40PB0F3	C17
IO41NB0F3/HCLKAN	E16
IO41PB0F3/HCLKAP	F16
IO42NB0F3/HCLKBN	G17
IO42PB0F3/HCLKBP	F17
Bank 1	
IO43NB1F4/HCLKCN	G19
IO43PB1F4/HCLKCP	G18
IO44NB1F4/HCLKDN	E19
IO44PB1F4/HCLKDP	F19
IO45NB1F4	C18
IO45PB1F4	D18
IO46NB1F4	A18
IO46PB1F4	B18
IO47NB1F4	K19
IO47PB1F4	L19
IO48NB1F4	C19
IO48PB1F4	D19
IO49NB1F4	K20
IO49PB1F4	L20
IO50NB1F4	A19
IO50PB1F4	B19
IO51NB1F4	H20
IO51PB1F4	J20
IO52NB1F4	B20
IO52PB1F4	A20
IO53NB1F4	F20
IO53PB1F4	E20
IO54NB1F5	B21

CG1152/LG1152	
RTAX2000S/SL Function	Pin Number
IO54PB1F5	A21
IO55NB1F5	K21
IO55PB1F5	J21
IO56NB1F5	D21
IO56PB1F5	C21
IO57NB1F5	G22
IO57PB1F5	G21
IO58NB1F5	E22
IO58PB1F5	E21
IO59NB1F5	D22
IO59PB1F5	C22
IO60NB1F5	B23
IO60PB1F5	A23
IO61NB1F5	H22
IO61PB1F5	H21
IO62NB1F5	C24
IO62PB1F5	C23
IO63NB1F5	F23
IO63PB1F5	F22
IO64NB1F6	B24
IO64PB1F6	A24
IO65NB1F6	J22
IO65PB1F6	K22
IO66NB1F6	B25
IO66PB1F6	A25
IO67NB1F6	K23
IO67PB1F6	J23
IO68NB1F6	F24
IO68PB1F6	E24
IO69NB1F6	C27
IO69PB1F6	C26
IO70NB1F6	H24
IO70PB1F6	G24
IO71NB1F6	H23
IO71PB1F6	G23
IO72NB1F6	B28
IO72PB1F6	A28

CG1152/LG1152	
RTAX2000S/SL Function	Pin Number
IO73NB1F6	E26
IO73PB1F6	E25
IO74NB1F6	F26
IO74PB1F6	F25
IO75NB1F6	K25
IO75PB1F6	K24
IO76NB1F7	D27
IO76PB1F7	D26
IO77NB1F7	B29
IO77PB1F7	A29
IO78NB1F7	D28
IO78PB1F7	C28
IO79NB1F7	H25
IO79PB1F7	G25
IO80NB1F7	F27
IO80PB1F7	E27
IO81NB1F7	J25
IO81PB1F7	J24
IO82NB1F7	D29
IO82PB1F7	C29
IO83NB1F7	H26
IO83PB1F7	G26
IO84NB1F7	F28
IO84PB1F7	E28
IO85NB1F7	H27
IO85PB1F7	G27
Bank 2	
IO86NB2F8	J28
IO86PB2F8	J27
IO87NB2F8	M25
IO87PB2F8	L25
IO88NB2F8	L26
IO88PB2F8	K26
IO89NB2F8	G31
IO89PB2F8	F31
IO90NB2F8	H29
IO90PB2F8	G29

CG1152/LG1152	
RTAX2000S/SL Function	Pin Number
IO91NB2F8	K28
IO91PB2F8	K27
IO92NB2F8	J30
IO92PB2F8	H30
IO93NB2F8	L28
IO93PB2F8	L27
IO94NB2F8	K29
IO94PB2F8	J29
IO95NB2F8	K31
IO95PB2F8	J31
IO96NB2F9	J32
IO96PB2F9	H32
IO97NB2F9	M27
IO97PB2F9	M26
IO98NB2F9	L30
IO98PB2F9	K30
IO99NB2F9	N25
IO99PB2F9	N26
IO100NB2F9	M29
IO100PB2F9	L29
IO101NB2F9	L33
IO101PB2F9	L32
IO102NB2F9	K34
IO102PB2F9	K33
IO103NB2F9	N28
IO103PB2F9	M28
IO104NB2F9	M34
IO104PB2F9	L34
IO105NB2F9	P27
IO105PB2F9	N27
IO106NB2F9	M32
IO106PB2F9	M31
IO107NB2F10	P25
IO107PB2F10	P26
IO108NB2F10	N33
IO108PB2F10	M33
IO109NB2F10	P29

CG1152/LG1152	
RTAX2000S/SL Function	Pin Number
IO109PB2F10	N29
IO110NB2F10	P30
IO110PB2F10	N30
IO111NB2F10	R24
IO111PB2F10	R25
IO112NB2F10	P31
IO112PB2F10	N31
IO113NB2F10	R28
IO113PB2F10	P28
IO114NB2F10	P32
IO114PB2F10	N32
IO115NB2F10	R30
IO115PB2F10	R29
IO116NB2F10	P34
IO116PB2F10	P33
IO117NB2F10	R27
IO117PB2F10	R26
IO118NB2F11	R34
IO118PB2F11	R33
IO119NB2F11	T24
IO119PB2F11	T25
IO120NB2F11	T33
IO120PB2F11	T34
IO121NB2F11	T27
IO121PB2F11	T26
IO122NB2F11	T30
IO122PB2F11	T29
IO123NB2F11	U28
IO123PB2F11	T28
IO124NB2F11	T31
IO124PB2F11	T32
IO125NB2F11	U24
IO125PB2F11	U25
IO126NB2F11	U33
IO126PB2F11	U34
IO127NB2F11	U26
IO127PB2F11	U27

CG1152/LG1152	
RTAX2000S/SL Function	Pin Number
IO128NB2F11	U31
IO128PB2F11	U32
Bank 3	
IO129NB3F12	V29
IO129PB3F12	U29
IO130NB3F12	V31
IO130PB3F12	V32
IO131NB3F12	V24
IO131PB3F12	V25
IO132NB3F12	W28
IO132PB3F12	V28
IO133NB3F12	W26
IO133PB3F12	V26
IO134NB3F12	W33
IO134PB3F12	V33
IO135NB3F12	W25
IO135PB3F12	W24
IO136NB3F12	W31
IO136PB3F12	W32
IO137NB3F12	Y30
IO137PB3F12	W30
IO138NB3F12	Y29
IO138PB3F12	W29
IO139NB3F13	Y27
IO139PB3F13	W27
IO140NB3F13	AA33
IO140PB3F13	Y33
IO141NB3F13	Y25
IO141PB3F13	Y24
IO142NB3F13	AA31
IO142PB3F13	Y31
IO143NB3F13	AA28
IO143PB3F13	Y28
IO144NB3F13	AA34
IO144PB3F13	Y34
IO145NB3F13	AA26
IO145PB3F13	Y26

CG1152/LG1152	
RTAX2000S/SL Function	Pin Number
IO146NB3F13	AA29
IO146PB3F13	AA30
IO147NB3F13	AB30
IO147PB3F13	AB29
IO148NB3F13	AB32
IO148PB3F13	AA32
IO149NB3F13	AB27
IO149PB3F13	AA27
IO150NB3F14	AC31
IO150PB3F14	AB31
IO151NB3F14	AD33
IO151PB3F14	AC33
IO152NB3F14	AC28
IO152PB3F14	AB28
IO153NB3F14	AB25
IO153PB3F14	AA25
IO154NB3F14	AD32
IO154PB3F14	AC32
IO155NB3F14	AD29
IO155PB3F14	AC29
IO156NB3F14	AE30
IO156PB3F14	AD30
IO157NB3F14	AC26
IO157PB3F14	AB26
IO158NB3F14	AH33
IO158PB3F14	AG33
IO159NB3F14	AD27
IO159PB3F14	AC27
IO160NB3F14	AG32
IO160PB3F14	AF32
IO161NB3F15	AG31
IO161PB3F15	AF31
IO162NB3F15	AF29
IO162PB3F15	AE29
IO163NB3F15	AE28
IO163PB3F15	AD28
IO164NB3F15	AG30

CG1152/LG1152	
RTAX2000S/SL Function	Pin Number
IO164PB3F15	AF30
IO165NB3F15	AE26
IO165PB3F15	AD26
IO166NB3F15	AJ30
IO166PB3F15	AH30
IO167NB3F15	AG28
IO167PB3F15	AF28
IO168NB3F15	AF27
IO168PB3F15	AE27
IO169NB3F15	AH29
IO169PB3F15	AG29
IO170NB3F15	AD25
IO170PB3F15	AC25
Bank 4	
IO171NB4F16	AP29
IO171PB4F16	AN29
IO172NB4F16	AH26
IO172PB4F16	AH27
IO173NB4F16	AJ27
IO173PB4F16	AJ28
IO174NB4F16	AL27
IO174PB4F16	AL28
IO175NB4F16	AM28
IO175PB4F16	AM29
IO176NB4F16	AG25
IO176PB4F16	AG26
IO177NB4F16	AK26
IO177PB4F16	AK27
IO178NB4F16	AF25
IO178PB4F16	AE25
IO179NB4F16	AP28
IO179PB4F16	AN28
IO180NB4F16	AJ25
IO180PB4F16	AJ26
IO181NB4F17	AM26
IO181PB4F17	AM27
IO182NB4F17	AF24

CG1152/LG1152	
RTAX2000S/SL Function	Pin Number
IO182PB4F17	AE24
IO183NB4F17	AH24
IO183PB4F17	AH25
IO184NB4F17	AG23
IO184PB4F17	AG24
IO185NB4F17	AL25
IO185PB4F17	AL26
IO186NB4F17	AP25
IO186PB4F17	AP26
IO187NB4F17	AK24
IO187PB4F17	AK25
IO188NB4F17	AF23
IO188PB4F17	AE23
IO189NB4F17	AN24
IO189PB4F17	AM24
IO190NB4F17	AH22
IO190PB4F17	AH23
IO191NB4F17	AJ23
IO191PB4F17	AJ24
IO192NB4F17	AG21
IO192PB4F17	AG22
IO193NB4F18	AP23
IO193PB4F18	AP24
IO194NB4F18	AN22
IO194PB4F18	AN23
IO195NB4F18	AM23
IO195PB4F18	AL23
IO196NB4F18	AF21
IO196PB4F18	AF22
IO197NB4F18	AL22
IO197PB4F18	AM22
IO198NB4F18	AE21
IO198PB4F18	AE22
IO199NB4F18	AJ21
IO199PB4F18	AJ22
IO200NB4F18	AK21
IO200PB4F18	AK22

CG1152/LG1152	
RTAX2000S/SL Function	Pin Number
IO201NB4F18	AM21
IO201PB4F18	AL21
IO202NB4F18	AE20
IO202PB4F18	AD20
IO203NB4F19	AN21
IO203PB4F19	AP21
IO204NB4F19	AP20
IO204PB4F19	AN20
IO205NB4F19	AN19
IO205PB4F19	AP19
IO206NB4F19	AG20
IO206PB4F19	AF20
IO207NB4F19	AL19
IO207PB4F19	AL20
IO208NB4F19	AG19
IO208PB4F19	AF19
IO209NB4F19	AN18
IO209PB4F19	AP18
IO210NB4F19	AE19
IO210PB4F19	AD19
IO211NB4F19	AL18
IO211PB4F19	AM18
IO212NB4F19/CLKEN	AJ20
IO212PB4F19/CLKEP	AK20
IO213NB4F19/CLKFN	AJ18
IO213PB4F19/CLKFP	AJ19
Bank 5	
IO214NB5F20/CLKGN	AJ16
IO214PB5F20/CLKGP	AJ17
IO215NB5F20/CLKHN	AJ15
IO215PB5F20/CLKHP	AK15
IO216NB5F20	AD16
IO216PB5F20	AE17
IO217NB5F20	AM17
IO217PB5F20	AL17
IO218NB5F20	AG16
IO218PB5F20	AF16

CG1152/LG1152	
RTAX2000S/SL Function	Pin Number
IO219NB5F20	AM16
IO219PB5F20	AL16
IO220NB5F20	AP16
IO220PB5F20	AN16
IO221NB5F20	AN15
IO221PB5F20	AP15
IO222NB5F20	AD15
IO222PB5F20	AE16
IO223NB5F21	AL14
IO223PB5F21	AL15
IO224NB5F21	AN14
IO224PB5F21	AP14
IO225NB5F21	AK13
IO225PB5F21	AK14
IO226NB5F21	AE15
IO226PB5F21	AF15
IO227NB5F21	AG14
IO227PB5F21	AG15
IO228NB5F21	AJ13
IO228PB5F21	AJ14
IO229NB5F21	AM13
IO229PB5F21	AM14
IO230NB5F21	AE14
IO230PB5F21	AF14
IO231NB5F21	AN12
IO231PB5F21	AP12
IO232NB5F21	AG13
IO232PB5F21	AH13
IO233NB5F21	AL12
IO233PB5F21	AL13
IO234NB5F21	AE13
IO234PB5F21	AF13
IO235NB5F22	AN11
IO235PB5F22	AP11
IO236NB5F22	AM11
IO236PB5F22	AM12
IO237NB5F22	AJ11

CG1152/LG1152	
RTAX2000S/SL Function	Pin Number
IO237PB5F22	AJ12
IO238NB5F22	AH11
IO238PB5F22	AH12
IO239NB5F22	AK10
IO239PB5F22	AK11
IO240NB5F22	AE12
IO240PB5F22	AF12
IO241NB5F22	AN10
IO241PB5F22	AP10
IO242NB5F22	AG11
IO242PB5F22	AG12
IO243NB5F22	AL9
IO243PB5F22	AL10
IO244NB5F22	AM8
IO244PB5F22	AM9
IO245NB5F23	AH10
IO245PB5F23	AJ10
IO246NB5F23	AF10
IO246PB5F23	AF11
IO247NB5F23	AJ9
IO247PB5F23	AK9
IO248NB5F23	AN7
IO248PB5F23	AP7
IO249NB5F23	AL7
IO249PB5F23	AL8
IO250NB5F23	AE10
IO250PB5F23	AE11
IO251NB5F23	AK8
IO251PB5F23	AJ8
IO252NB5F23	AH8
IO252PB5F23	AH9
IO253NB5F23	AN6
IO253PB5F23	AP6
IO254NB5F23	AG9
IO254PB5F23	AG10
IO255NB5F23	AJ7
IO255PB5F23	AK7

CG1152/LG1152	
RTAX2000S/SL Function	Pin Number
IO256NB5F23	AL6
IO256PB5F23	AM6
Bank 6	
IO257NB6F24	AG6
IO257PB6F24	AH6
IO258NB6F24	AD9
IO258PB6F24	AE9
IO259NB6F24	AF7
IO259PB6F24	AG7
IO260NB6F24	AH3
IO260PB6F24	AH4
IO261NB6F24	AH5
IO261PB6F24	AJ5
IO262NB6F24	AE6
IO262PB6F24	AF6
IO263NB6F24	AF5
IO263PB6F24	AG5
IO264NB6F24	AD8
IO264PB6F24	AE8
IO265NB6F24	AF3
IO265PB6F24	AG3
IO266NB6F24	AC10
IO266PB6F24	AD10
IO267NB6F25	AD7
IO267PB6F25	AE7
IO268NB6F25	AD5
IO268PB6F25	AE5
IO269NB6F25	AE4
IO269PB6F25	AF4
IO270NB6F25	AB9
IO270PB6F25	AC9
IO271NB6F25	AC6
IO271PB6F25	AD6
IO272NB6F25	AB8
IO272PB6F25	AC8
IO273NB6F25	AE1
IO273PB6F25	AE2

CG1152/LG1152		CG1152/LG1152		CG1152/LG1152	
RTAX2000S/SL Function	Pin Number	RTAX2000S/SL Function	Pin Number	RTAX2000S/SL Function	Pin Number
IO274NB6F25	AA10	IO292PB6F27	W7	IO310PB7F29	T8
IO274PB6F25	AB10	IO293NB6F27	W4	IO311NB7F29	N3
IO275NB6F25	AB7	IO293PB6F27	Y4	IO311PB7F29	P3
IO275PB6F25	AC7	IO294NB6F27	V10	IO312NB7F29	P7
IO276NB6F25	AD1	IO294PB6F27	V11	IO312PB7F29	R7
IO276PB6F25	AD2	IO295NB6F27	Y1	IO313NB7F29	P6
IO277NB6F25	AC4	IO295PB6F27	Y2	IO313PB7F29	R6
IO277PB6F25	AC3	IO296NB6F27	W1	IO314NB7F29	M2
IO278NB6F26	AA8	IO296PB6F27	W2	IO314PB7F29	N2
IO278PB6F26	AA9	IO297NB6F27	V1	IO315NB7F29	N4
IO279NB6F26	AB5	IO297PB6F27	V2	IO315PB7F29	P4
IO279PB6F26	AB6	IO298NB6F27	V9	IO316NB7F29	R9
IO280NB6F26	Y10	IO298PB6F27	V8	IO316PB7F29	R8
IO280PB6F26	Y11	IO299NB6F27	U4	IO317NB7F29	N5
IO281NB6F26	AB3	IO299PB6F27	V4	IO317PB7F29	P5
IO281PB6F26	AB4	Bank 7		IO318NB7F29	R10
IO282NB6F26	Y7	IO300NB7F28	U10	IO318PB7F29	R11
IO282PB6F26	AA7	IO300PB7F28	U11	IO319NB7F29	L2
IO283NB6F26	AC2	IO301NB7F28	U2	IO319PB7F29	L1
IO283PB6F26	AC1	IO301PB7F28	U1	IO320NB7F29	N8
IO284NB6F26	Y9	IO302NB7F28	U6	IO320PB7F29	P8
IO284PB6F26	Y8	IO302PB7F28	U7	IO321NB7F30	M6
IO285NB6F26	AA5	IO303NB7F28	T3	IO321PB7F30	N6
IO285PB6F26	AA6	IO303PB7F28	U3	IO322NB7F30	P10
IO286NB6F26	W10	IO304NB7F28	U9	IO322PB7F30	P9
IO286PB6F26	W11	IO304PB7F28	U8	IO323NB7F30	L3
IO287NB6F26	AA3	IO305NB7F28	R2	IO323PB7F30	M3
IO287PB6F26	AA4	IO305PB7F28	R1	IO324NB7F30	M7
IO288NB6F26	W9	IO306NB7F28	R4	IO324PB7F30	N7
IO288PB6F26	W8	IO306PB7F28	T4	IO325NB7F30	K2
IO289NB6F27	AA1	IO307NB7F28	R5	IO325PB7F30	K1
IO289PB6F27	AA2	IO307PB7F28	T5	IO326NB7F30	G2
IO290NB6F27	W6	IO308NB7F28	T11	IO326PB7F30	H2
IO290PB6F27	Y6	IO308PB7F28	T10	IO327NB7F30	L6
IO291NB6F27	W5	IO309NB7F28	T6	IO327PB7F30	L5
IO291PB6F27	Y5	IO309PB7F28	T7	IO328NB7F30	N10
IO292NB6F27	V7	IO310NB7F29	T9	IO328PB7F30	N9

CG1152/LG1152	
RTAX2000S/SL Function	Pin Number
IO329NB7F30	J4
IO329PB7F30	K4
IO330NB7F30	J5
IO330PB7F30	K5
IO331NB7F30	M10
IO331PB7F30	M9
IO332NB7F31	L8
IO332PB7F31	M8
IO333NB7F31	F2
IO333PB7F31	F1
IO334NB7F31	J6
IO334PB7F31	K6
IO335NB7F31	H4
IO335PB7F31	H3
IO336NB7F31	K7
IO336PB7F31	L7
IO337NB7F31	G4
IO337PB7F31	G3
IO338NB7F31	K9
IO338PB7F31	L9
IO339NB7F31	H6
IO339PB7F31	H5
IO340NB7F31	H7
IO340PB7F31	J7
IO341NB7F31	J8
IO341PB7F31	K8
Dedicated I/O	
GND	A13
GND	A2
GND	A22
GND	A27
GND	A3
GND	A31
GND	A32
GND	A33
GND	A4
GND	A8

CG1152/LG1152	
RTAX2000S/SL Function	Pin Number
GND	AA14
GND	AA15
GND	AA16
GND	AA17
GND	AA18
GND	AA19
GND	AA20
GND	AA21
GND	AB1
GND	AB13
GND	AB22
GND	AB34
GND	AC12
GND	AC23
GND	AC30
GND	AC5
GND	AD11
GND	AD24
GND	AD31
GND	AD4
GND	AE3
GND	AE32
GND	AF2
GND	AF33
GND	AG1
GND	AG27
GND	AG34
GND	AG8
GND	AH28
GND	AH7
GND	AJ29
GND	AJ6
GND	AK12
GND	AK17
GND	AK18
GND	AK23
GND	AK30

CG1152/LG1152	
RTAX2000S/SL Function	Pin Number
GND	AK5
GND	AL1
GND	AL11
GND	AL2
GND	AL24
GND	AL3
GND	AL31
GND	AL32
GND	AL33
GND	AL34
GND	AL4
GND	AM1
GND	AM10
GND	AM15
GND	AM2
GND	AM20
GND	AM25
GND	AM3
GND	AM31
GND	AM32
GND	AM33
GND	AM34
GND	AM4
GND	AN1
GND	AN2
GND	AN26
GND	AN3
GND	AN31
GND	AN32
GND	AN33
GND	AN34
GND	AN4
GND	AN9
GND	AP13
GND	AP2
GND	AP22
GND	AP27

CG1152/LG1152	
RTAX2000S/SL Function	Pin Number
GND	AP3
GND	AP31
GND	AP32
GND	AP33
GND	AP4
GND	AP8
GND	B1
GND	B2
GND	B26
GND	B3
GND	B31
GND	B32
GND	B33
GND	B34
GND	B4
GND	B9
GND	C1
GND	C10
GND	C15
GND	C2
GND	C20
GND	C25
GND	C3
GND	C31
GND	C32
GND	C33
GND	C34
GND	C4
GND	D1
GND	D11
GND	D2
GND	D24
GND	D3
GND	D31
GND	D32
GND	D33
GND	D34

CG1152/LG1152	
RTAX2000S/SL Function	Pin Number
GND	D4
GND	E12
GND	E17
GND	E18
GND	E23
GND	E30
GND	E5
GND	F29
GND	F30
GND	F6
GND	G28
GND	G6
GND	G7
GND	H1
GND	H34
GND	J2
GND	J33
GND	K3
GND	K32
GND	L11
GND	L24
GND	L31
GND	L4
GND	M12
GND	M23
GND	M30
GND	M5
GND	N1
GND	N13
GND	N22
GND	N34
GND	P14
GND	P15
GND	P16
GND	P17
GND	P18
GND	P19

CG1152/LG1152	
RTAX2000S/SL Function	Pin Number
GND	P20
GND	P21
GND	R14
GND	R15
GND	R16
GND	R17
GND	R18
GND	R19
GND	R20
GND	R21
GND	R3
GND	R32
GND	T14
GND	T15
GND	T16
GND	T17
GND	T18
GND	T19
GND	T20
GND	T21
GND	U14
GND	U15
GND	U16
GND	U17
GND	U18
GND	U19
GND	U20
GND	U21
GND	U30
GND	U5
GND	V14
GND	V15
GND	V16
GND	V17
GND	V18
GND	V19
GND	V20

CG1152/LG1152	
RTAX2000S/SL Function	Pin Number
GND	V21
GND	V30
GND	V5
GND	W14
GND	W15
GND	W16
GND	W17
GND	W18
GND	W19
GND	W20
GND	W21
GND	Y14
GND	Y15
GND	Y16
GND	Y17
GND	Y18
GND	Y19
GND	Y20
GND	Y21
GND	Y3
GND	Y32
NC	A17
NC	A26
NC	AB2
NC	AB33
NC	AC34
NC	AD17
NC	AD3
NC	AD34
NC	AE18
NC	AE31
NC	AE33
NC	AE34
NC	AF1
NC	AF17
NC	AF18
NC	AF34

CG1152/LG1152	
RTAX2000S/SL Function	Pin Number
NC	AG2
NC	AG4
NC	AH1
NC	AH16
NC	AH19
NC	AH2
NC	AH31
NC	AH32
NC	AH34
NC	AJ1
NC	AJ2
NC	AJ3
NC	AJ31
NC	AJ32
NC	AJ33
NC	AJ34
NC	AJ4
NC	AK16
NC	AK19
NC	AL29
NC	AM19
NC	AM7
NC	AN13
NC	AN17
NC	AN25
NC	AN27
NC	AN8
NC	AP17
NC	AP9
NC	B17
NC	B22
NC	B27
NC	B8
NC	D10
NC	D20
NC	D23
NC	D25

CG1152/LG1152	
RTAX2000S/SL Function	Pin Number
NC	F3
NC	F32
NC	F33
NC	F34
NC	F4
NC	G1
NC	G32
NC	G33
NC	G34
NC	H16
NC	H19
NC	H31
NC	H33
NC	J1
NC	J16
NC	J19
NC	J3
NC	J34
NC	K17
NC	K18
NC	L17
NC	L18
NC	M1
NC	M4
NC	P1
NC	P2
NC	R31
NC	T1
NC	T2
NC	V3
NC	V34
NC	W3
NC	W34
PRA	J17
PRB	F18
PRC	AD18
PRD	AH18

CG1152/LG1152		CG1152/LG1152		CG1152/LG1152	
RTAX2000S/SL Function	Pin Number	RTAX2000S/SL Function	Pin Number	RTAX2000S/SL Function	Pin Number
TCK	J9	VCCA	W13	VCCIB0	M15
TDI	F7	VCCA	W22	VCCIB0	M16
TDO	L10	VCCA	Y13	VCCIB0	M17
TMS	H8	VCCA	Y22	VCCIB1	A30
TRST	E6	VCCDA	AF26	VCCIB1	B30
VCCA	AA13	VCCDA	AF9	VCCIB1	C30
VCCA	AA22	VCCDA	AG17	VCCIB1	D30
VCCA	AB14	VCCDA	AG18	VCCIB1	L21
VCCA	AB15	VCCDA	AH14	VCCIB1	L22
VCCA	AB16	VCCDA	AH15	VCCIB1	L23
VCCA	AB17	VCCDA	AH17	VCCIB1	M18
VCCA	AB18	VCCDA	AH20	VCCIB1	M19
VCCA	AB19	VCCDA	AH21	VCCIB1	M20
VCCA	AB20	VCCDA	AK29	VCCIB1	M21
VCCA	AB21	VCCDA	AK6	VCCIB1	M22
VCCA	AF8	VCCDA	E15	VCCIB2	E31
VCCA	AK28	VCCDA	E29	VCCIB2	E32
VCCA	G30	VCCDA	E7	VCCIB2	E33
VCCA	G5	VCCDA	F15	VCCIB2	E34
VCCA	N14	VCCDA	F21	VCCIB2	M24
VCCA	N15	VCCDA	F5	VCCIB2	N23
VCCA	N16	VCCDA	G20	VCCIB2	N24
VCCA	N17	VCCDA	H17	VCCIB2	P23
VCCA	N18	VCCDA	H18	VCCIB2	P24
VCCA	N19	VCCDA	H28	VCCIB2	R23
VCCA	N20	VCCDA	J18	VCCIB2	T23
VCCA	N21	VCCDA	V27	VCCIB2	U23
VCCA	P13	VCCDA	V6	VCCIB3	AA23
VCCA	P22	VCCIB0	A5	VCCIB3	AA24
VCCA	R13	VCCIB0	B5	VCCIB3	AB23
VCCA	R22	VCCIB0	C5	VCCIB3	AB24
VCCA	T13	VCCIB0	D5	VCCIB3	AC24
VCCA	T22	VCCIB0	L12	VCCIB3	AK31
VCCA	U13	VCCIB0	L13	VCCIB3	AK32
VCCA	U22	VCCIB0	L14	VCCIB3	AK33
VCCA	V13	VCCIB0	M13	VCCIB3	AK34
VCCA	V22	VCCIB0	M14	VCCIB3	V23

CG1152/LG1152	
RTAX2000S/SL Function	Pin Number
VCCIB3	W23
VCCIB3	Y23
VCCIB4	AC18
VCCIB4	AC19
VCCIB4	AC20
VCCIB4	AC21
VCCIB4	AC22
VCCIB4	AD21
VCCIB4	AD22
VCCIB4	AD23
VCCIB4	AL30
VCCIB4	AM30
VCCIB4	AN30
VCCIB4	AP30
VCCIB5	AC13
VCCIB5	AC14
VCCIB5	AC15
VCCIB5	AC16
VCCIB5	AC17
VCCIB5	AD12
VCCIB5	AD13
VCCIB5	AD14
VCCIB5	AL5
VCCIB5	AM5
VCCIB5	AN5
VCCIB5	AP5
VCCIB6	AA11
VCCIB6	AA12
VCCIB6	AB11
VCCIB6	AB12
VCCIB6	AC11
VCCIB6	AK1
VCCIB6	AK2
VCCIB6	AK3
VCCIB6	AK4
VCCIB6	V12
VCCIB6	W12

CG1152/LG1152	
RTAX2000S/SL Function	Pin Number
VCCIB6	Y12
VCCIB7	E1
VCCIB7	E2
VCCIB7	E3
VCCIB7	E4
VCCIB7	M11
VCCIB7	N11
VCCIB7	N12
VCCIB7	P11
VCCIB7	P12
VCCIB7	R12
VCCIB7	T12
VCCIB7	U12
VPUMP	J26

CG1272/LG1272

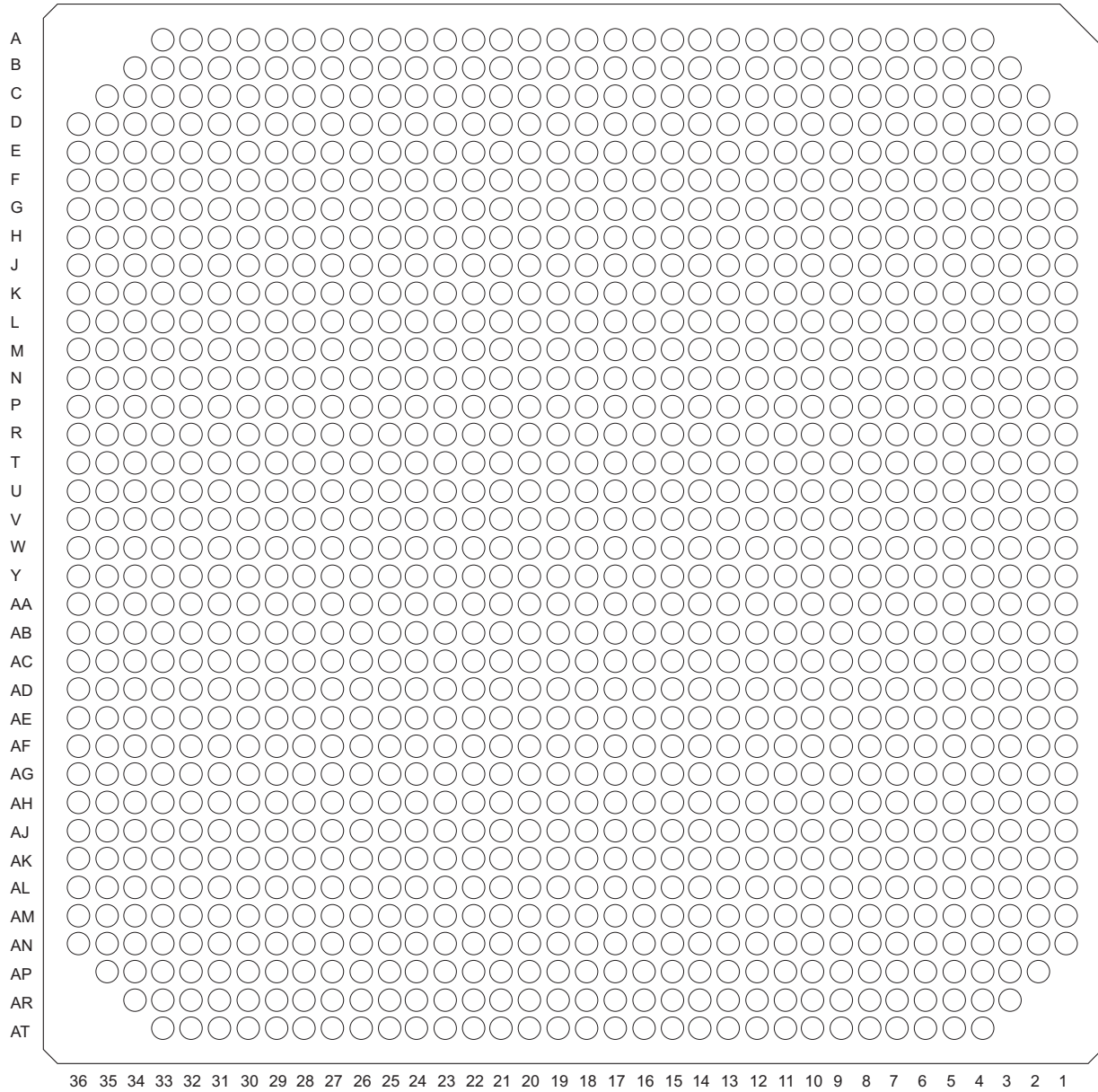

Note

For Package Manufacturing and Environmental information, visit the Resource center at <http://www.microsemi.com/soc/products/solutions/package/docs.aspx>.

CG1272/LG1272	
RTAX4000S/SL Function	Pin Number
Bank 0	
IO00NB0F0	E9
IO00PB0F0	D9
IO01NB0F0	D8
IO01PB0F0	D7
IO02NB0F0	J10
IO02PB0F0	J9
IO03NB0F0	E7
IO03PB0F0	E8
IO04NB0F0	F9
IO04PB0F0	G9
IO05NB0F0	B7
IO05PB0F0	B6
IO06NB0F0	L13
IO06PB0F0	L12
IO07NB0F0	C7
IO07PB0F0	C6
IO08NB0F0	F10
IO08PB0F0	G10
IO09NB0F0	D10
IO09PB0F0	E10
IO10NB0F0	H11
IO10PB0F0	H10
IO11NB0F0	A5
IO11PB0F0	A4
IO12NB0F1	D6
IO12PB0F1	D5
IO13NB0F1	A7
IO13PB0F1	A6
IO14NB0F1	J12
IO14PB0F1	J11
IO15NB0F1	D12
IO15PB0F1	D11
IO16NB0F1	F12
IO16PB0F1	G12

CG1272/LG1272	
RTAX4000S/SL Function	Pin Number
IO17NB0F1	E12
IO17PB0F1	E11
IO18NB0F1	K13
IO18PB0F1	K12
IO19NB0F1	B4
IO19PB0F1	C4
IO20NB0F1	H13
IO20PB0F1	H12
IO21NB0F2	C13
IO21PB0F2	C12
IO22NB0F2	M14
IO22PB0F2	M13
IO23NB0F2	B10
IO23PB0F2	B9
IO24NB0F2	J14
IO24PB0F2	J13
IO25NB0F2	A8
IO25PB0F2	A9
IO26NB0F2	G13
IO26PB0F2	F13
IO27NB0F2	D14
IO27PB0F2	D13
IO28NB0F2	L16
IO28PB0F2	L15
IO29NB0F2	B13
IO29PB0F2	B12
IO30NB0F2	C10
IO30PB0F2	C9
IO31NB0F2	E15
IO31PB0F2	E14
IO32NB0F2	K15
IO32PB0F2	K16
IO33NB0F3	A13
IO33PB0F3	A12
IO34NB0F3	G15

CG1272/LG1272	
RTAX4000S/SL Function	Pin Number
IO34PB0F3	F15
IO35NB0F3	C15
IO35PB0F3	D15
IO36NB0F3	J16
IO36PB0F3	J15
IO37NB0F3	A11
IO37PB0F3	A10
IO38NB0F3	H15
IO38PB0F3	H14
IO39NB0F3	B16
IO39PB0F3	B15
IO40NB0F3	M16
IO40PB0F3	M17
IO41NB0F3	E16
IO41PB0F3	F16
IO42NB0F4	H17
IO42PB0F4	J17
IO43NB0F4	A14
IO43PB0F4	A15
IO44NB0F4	G16
IO44PB0F4	H16
IO45NB0F4	A17
IO45PB0F4	A16
IO46NB0F4	M18
IO46PB0F4	M19
IO47NB0F4	E18
IO47PB0F4	E17
IO48NB0F4	G18
IO48PB0F4	H18
IO49NB0F4	C18
IO49PB0F4	B18
IO50NB0F4/HCLKAN	J18
IO50PB0F4/HCLKAP	K18
IO51NB0F4/HCLKBN	D18
IO51PB0F4/HCLKBP	D17

CG1272/LG1272		CG1272/LG1272		CG1272/LG1272	
RTAX4000S/SL Function	Pin Number	RTAX4000S/SL Function	Pin Number	RTAX4000S/SL Function	Pin Number
Bank 1		IO69NB1F7	A27	IO86PB1F9	F25
IO52NB1F6/HCLKCN	K19	IO69PB1F7	A26	IO87NB1F9	E26
IO52PB1F6/HCLKCP	J19	IO70NB1F7	F22	IO87PB1F9	E25
IO53NB1F6/HCLKDN	D20	IO70PB1F7	G22	IO88NB1F9	J26
IO53PB1F6/HCLKDP	D19	IO71NB1F7	E23	IO88PB1F9	J25
IO54NB1F6	H19	IO71PB1F7	E22	IO89NB1F9	D26
IO54PB1F6	G19	IO72NB1F8	L22	IO89PB1F9	D25
IO55NB1F6	B19	IO72PB1F8	L21	IO90NB1F9	E31
IO55PB1F6	C19	IO73NB1F8	A25	IO90PB1F9	E32
IO56NB1F6	M20	IO73PB1F8	A24	IO91NB1F9	A31
IO56PB1F6	M21	IO74NB1F8	C28	IO91PB1F9	A30
IO57NB1F6	E20	IO74PB1F8	C27	IO92NB1F9	H27
IO57PB1F6	E19	IO75NB1F8	D24	IO92PB1F9	H26
IO58NB1F6	H21	IO75PB1F8	D23	IO93NB1F9	C33
IO58PB1F6	G21	IO76NB1F8	J24	IO93PB1F9	B33
IO59NB1F6	A21	IO76PB1F8	J23	IO94NB1F10	G27
IO59PB1F6	A20	IO77NB1F8	B25	IO94PB1F10	F27
IO60NB1F7	H20	IO77PB1F8	B24	IO95NB1F10	E27
IO60PB1F7	J20	IO78NB1F8	F24	IO95PB1F10	D27
IO61NB1F7	A22	IO78PB1F8	G24	IO96NB1F10	L24
IO61PB1F7	A23	IO79NB1F8	A28	IO96PB1F10	L25
IO62NB1F7	D32	IO79PB1F8	A29	IO97NB1F10	C31
IO62PB1F7	D31	IO80NB1F8	M24	IO97PB1F10	C30
IO63NB1F7	F21	IO80PB1F8	M23	IO98NB1F10	F28
IO63PB1F7	E21	IO81NB1F8	B28	IO98PB1F10	G28
IO64NB1F7	J22	IO81PB1F8	B27	IO99NB1F10	B31
IO64PB1F7	J21	IO82NB1F9	H25	IO99PB1F10	B30
IO65NB1F7	B22	IO82PB1F9	H24	IO100NB1F10	J28
IO65PB1F7	B21	IO83NB1F9	C25	IO100PB1F10	J27
IO66NB1F7	H23	IO83PB1F9	C24	IO101NB1F10	E29
IO66PB1F7	H22	IO84NB1F9	K25	IO101PB1F10	E30
IO67NB1F7	D22	IO84PB1F9	K24	IO102NB1F10	D28
IO67PB1F7	C22	IO85NB1F9	A33	IO102PB1F10	E28
IO68NB1F7	K22	IO85PB1F9	A32	IO103NB1F10	D30
IO68PB1F7	K21	IO86NB1F9	G25	IO103PB1F10	D29

CG1272/LG1272	
RTAX4000S/SL Function	Pin Number
Bank 2	
IO104NB2F12	L29
IO104PB2F12	L28
IO105NB2F12	D35
IO105PB2F12	D34
IO106NB2F12	H33
IO106PB2F12	J33
IO107NB2F12	F34
IO107PB2F12	F33
IO108NB2F12	G33
IO108PB2F12	G32
IO109NB2F12	M28
IO109PB2F12	M27
IO110NB2F12	K33
IO110PB2F12	K32
IO111NB2F12	K31
IO111PB2F12	K30
IO112NB2F13	K34
IO112PB2F13	J34
IO113NB2F13	N26
IO113PB2F13	M26
IO114NB2F13	K28
IO114PB2F13	K29
IO115NB2F13	H32
IO115PB2F13	J32
IO116NB2F13	G35
IO116PB2F13	G34
IO117NB2F13	M29
IO117PB2F13	M30
IO118NB2F13	E33
IO118PB2F13	D33
IO119NB2F13	M32
IO119PB2F13	M31
IO120NB2F13	E36
IO120PB2F13	D36

CG1272/LG1272	
RTAX4000S/SL Function	Pin Number
IO121NB2F14	N28
IO121PB2F14	N27
IO122NB2F14	L33
IO122PB2F14	L32
IO123NB2F14	N30
IO123PB2F14	N29
IO124NB2F14	K35
IO124PB2F14	J35
IO125NB2F14	P25
IO125PB2F14	N25
IO126NB2F14	H36
IO126PB2F14	G36
IO127NB2F14	N32
IO127PB2F14	N31
IO128NB2F14	N34
IO128PB2F14	M34
IO129NB2F14	P29
IO129PB2F14	P28
IO130NB2F15	N33
IO130PB2F15	M33
IO131NB2F15	R26
IO131PB2F15	R25
IO132NB2F15	K36
IO132PB2F15	J36
IO133NB2F15	R29
IO133PB2F15	R28
IO134NB2F15	N35
IO134PB2F15	M35
IO135NB2F15	F35
IO135PB2F15	F36
IO136NB2F15	M36
IO136PB2F15	L36
IO137NB2F15	T26
IO137PB2F15	T25
IO138NB2F15	P33

CG1272/LG1272	
RTAX4000S/SL Function	Pin Number
IO138PB2F15	P32
IO139NB2F16	R31
IO139PB2F16	R30
IO140NB2F16	P36
IO140PB2F16	N36
IO141NB2F16	T28
IO141PB2F16	T27
IO142NB2F16	R35
IO142PB2F16	R34
IO143NB2F16	T32
IO143PB2F16	T31
IO144NB2F16	T35
IO144PB2F16	T34
IO145NB2F16	T30
IO145PB2F16	T29
IO146NB2F16	R33
IO146PB2F16	R32
IO147NB2F16	V25
IO147PB2F16	U25
IO148NB2F17	T36
IO148PB2F17	R36
IO149NB2F17	U29
IO149PB2F17	U28
IO150NB2F17	U33
IO150PB2F17	T33
IO151NB2F17	W25
IO151PB2F17	Y25
IO152NB2F17	V36
IO152PB2F17	U36
IO153NB2F17	V31
IO153PB2F17	V30
IO154NB2F17	V32
IO154PB2F17	U32
IO155NB2F17	V27
IO155PB2F17	V28

CG1272/LG1272		CG1272/LG1272		CG1272/LG1272	
RTAX4000S/SL Function	Pin Number	RTAX4000S/SL Function	Pin Number	RTAX4000S/SL Function	Pin Number
IO156NB2F17	W34	IO173NB3F19	AA27	IO190PB3F21	AK36
IO156PB2F17	V34	IO173PB3F19	AA28	IO191NB3F21	AE32
Bank 3		IO174NB3F19	AB34	IO191PB3F21	AE31
IO157NB3F18	W29	IO174PB3F19	AB35	IO192NB3F21	AN36
IO157PB3F18	V29	IO175NB3F20	AL35	IO192PB3F21	AM36
IO158NB3F18	W35	IO175PB3F20	AL36	IO193NB3F22	AD27
IO158PB3F18	V35	IO176NB3F20	AG36	IO193PB3F22	AD28
IO159NB3F18	W30	IO176PB3F20	AF36	IO194NB3F22	AF32
IO159PB3F18	W31	IO177NB3F20	AB25	IO194PB3F22	AF33
IO160NB3F18	AA36	IO177PB3F20	AB26	IO195NB3F22	AE30
IO160PB3F18	Y36	IO178NB3F20	AC32	IO195PB3F22	AE29
IO161NB3F18	W27	IO178PB3F20	AC33	IO196NB3F22	AK34
IO161PB3F18	W28	IO179NB3F20	AB29	IO196PB3F22	AL34
IO162NB3F18	Y32	IO179PB3F20	AB28	IO197NB3F22	AE28
IO162PB3F18	W32	IO180NB3F20	AJ36	IO197PB3F22	AE27
IO163NB3F18	Y28	IO180PB3F20	AH36	IO198NB3F22	AN33
IO163PB3F18	Y29	IO181NB3F20	AC25	IO198PB3F22	AM33
IO164NB3F18	AC36	IO181PB3F20	AD25	IO199NB3F22	AH31
IO164PB3F18	AB36	IO182NB3F20	AE35	IO199PB3F22	AH30
IO165NB3F18	AA26	IO182PB3F20	AD35	IO200NB3F22	AH34
IO165PB3F18	AA25	IO183NB3F20	AC29	IO200PB3F22	AG34
IO166NB3F19	AA33	IO183PB3F20	AC28	IO201NB3F22	AF29
IO166PB3F19	Y33	IO184NB3F21	AE34	IO201PB3F22	AF28
IO167NB3F19	AA32	IO184PB3F21	AD34	IO202NB3F23	AG32
IO167PB3F19	AA31	IO185NB3F21	AE26	IO202PB3F23	AG33
IO168NB3F19	AA34	IO185PB3F21	AD26	IO203NB3F23	AG31
IO168PB3F19	AA35	IO186NB3F21	AE33	IO203PB3F23	AG30
IO169NB3F19	AA29	IO186PB3F21	AD33	IO204NB3F23	AL33
IO169PB3F19	AA30	IO187NB3F21	AD30	IO204PB3F23	AK33
IO170NB3F19	AB32	IO187PB3F21	AD29	IO205NB3F23	AK32
IO170PB3F19	AB33	IO188NB3F21	AH35	IO205PB3F23	AK31
IO171NB3F19	AB31	IO188PB3F21	AG35	IO206NB3F23	AH33
IO171PB3F19	AB30	IO189NB3F21	AD32	IO206PB3F23	AJ33
IO172NB3F19	AE36	IO189PB3F21	AD31	IO207NB3F23	AN34
IO172PB3F19	AD36	IO190NB3F21	AK35	IO207PB3F23	AN35

CG1272/LG1272	
RTAX4000S/SL Function	Pin Number
IO208NB3F23	AG29
IO208PB3F23	AG28
IO209NB3F23	AJ32
IO209PB3F23	AH32
Bank 4	
IO210NB4F24	AM28
IO210PB4F24	AN28
IO211NB4F24	AN29
IO211PB4F24	AN30
IO212NB4F24	AH27
IO212PB4F24	AH28
IO213NB4F24	AM30
IO213PB4F24	AM29
IO214NB4F24	AL28
IO214PB4F24	AK28
IO215NB4F24	AR30
IO215PB4F24	AR31
IO216NB4F24	AF24
IO216PB4F24	AF25
IO217NB4F24	AP30
IO217PB4F24	AP31
IO218NB4F24	AL27
IO218PB4F24	AK27
IO219NB4F24	AN27
IO219PB4F24	AM27
IO220NB4F25	AJ26
IO220PB4F25	AJ27
IO221NB4F25	AT32
IO221PB4F25	AT33
IO222NB4F25	AN31
IO222PB4F25	AN32
IO223NB4F25	AT30
IO223PB4F25	AT31
IO224NB4F25	AH25
IO224PB4F25	AH26

CG1272/LG1272	
RTAX4000S/SL Function	Pin Number
IO225NB4F25	AN25
IO225PB4F25	AN26
IO226NB4F25	AL25
IO226PB4F25	AK25
IO227NB4F25	AM25
IO227PB4F25	AM26
IO228NB4F25	AG25
IO228PB4F25	AG24
IO229NB4F25	AR33
IO229PB4F25	AP33
IO230NB4F25	AJ24
IO230PB4F25	AJ25
IO231NB4F25	AT26
IO231PB4F25	AT27
IO232NB4F26	AE23
IO232PB4F26	AE24
IO233NB4F26	AR27
IO233PB4F26	AR28
IO234NB4F26	AH23
IO234PB4F26	AH24
IO235NB4F26	AT29
IO235PB4F26	AT28
IO236NB4F26	AK24
IO236PB4F26	AL24
IO237NB4F26	AR24
IO237PB4F26	AR25
IO238NB4F26	AF21
IO238PB4F26	AF22
IO239NB4F26	AP24
IO239PB4F26	AP25
IO240NB4F26	AP27
IO240PB4F26	AP28
IO241NB4F26	AN23
IO241PB4F26	AN24
IO242NB4F27	AG21

CG1272/LG1272	
RTAX4000S/SL Function	Pin Number
IO242PB4F27	AG22
IO243NB4F27	AM22
IO243PB4F27	AM23
IO244NB4F27	AK22
IO244PB4F27	AL22
IO245NB4F27	AT24
IO245PB4F27	AT25
IO246NB4F27	AH21
IO246PB4F27	AH22
IO247NB4F27	AP22
IO247PB4F27	AN22
IO248NB4F27	AJ22
IO248PB4F27	AJ23
IO249NB4F27	AR21
IO249PB4F27	AR22
IO250NB4F27	AE21
IO250PB4F27	AE20
IO251NB4F27	AM21
IO251PB4F27	AL21
IO252NB4F27	AH20
IO252PB4F27	AJ20
IO253NB4F27	AT23
IO253PB4F27	AT22
IO254NB4F28	AK21
IO254PB4F28	AJ21
IO255NB4F28	AT20
IO255PB4F28	AT21
IO256NB4F28	AE18
IO256PB4F28	AE19
IO257NB4F28	AM19
IO257PB4F28	AM20
IO258NB4F28	AK19
IO258PB4F28	AJ19
IO259NB4F28	AP19
IO259PB4F28	AR19

CG1272/LG1272		CG1272/LG1272		CG1272/LG1272	
RTAX4000S/SL Function	Pin Number	RTAX4000S/SL Function	Pin Number	RTAX4000S/SL Function	Pin Number
IO260NB4F28/CLKEN	AH19	IO277NB5F31	AN15	IO294PB5F33	AF13
IO260PB4F28/CLKEP	AG19	IO277PB5F31	AP15	IO295NB5F33	AP4
IO261NB4F28/CLKFN	AN19	IO278NB5F31	AG15	IO295PB5F33	AR4
IO261PB4F28/CLKFP	AN20	IO278PB5F31	AG16	IO296NB5F33	AG12
Bank 5		IO279NB5F31	AT10	IO296PB5F33	AF12
IO262NB5F30/CLKGN	AG18	IO279PB5F31	AT11	IO297NB5F33	AM11
IO262PB5F30/CLKGP	AH18	IO280NB5F31	AL15	IO297PB5F33	AM12
IO263NB5F30/CLKHN	AN17	IO280PB5F31	AK15	IO298NB5F33	AK12
IO263PB5F30/CLKHP	AN18	IO281NB5F32	AM14	IO298PB5F33	AL12
IO264NB5F30	AJ18	IO281PB5F32	AM15	IO299NB5F33	AN11
IO264PB5F30	AK18	IO282NB5F32	AE13	IO299PB5F33	AN12
IO265NB5F30	AR18	IO282PB5F32	AE14	IO300NB5F33	AN5
IO265PB5F30	AP18	IO283NB5F32	AT12	IO300PB5F33	AN6
IO266NB5F30	AE17	IO283PB5F32	AT13	IO301NB5F33	AT6
IO266PB5F30	AE16	IO284NB5F32	AP9	IO301PB5F33	AT7
IO267NB5F30	AM17	IO284PB5F32	AP10	IO302NB5F34	AH11
IO267PB5F30	AM18	IO285NB5F32	AN13	IO302PB5F34	AH12
IO268NB5F30	AJ16	IO285PB5F32	AN14	IO303NB5F34	AT4
IO268PB5F30	AK16	IO286NB5F32	AN9	IO303PB5F34	AT5
IO269NB5F30	AT16	IO286PB5F32	AM9	IO304NB5F34	AJ10
IO269PB5F30	AT17	IO287NB5F32	AR12	IO304PB5F34	AJ11
IO270NB5F30	AF16	IO287PB5F32	AR13	IO305NB5F34	AM10
IO270PB5F30	AF15	IO288NB5F32	AL13	IO305PB5F34	AN10
IO271NB5F30	AT15	IO288PB5F32	AK13	IO306NB5F34	AK10
IO271PB5F30	AT14	IO289NB5F32	AT9	IO306PB5F34	AL10
IO272NB5F31	AH17	IO289PB5F32	AT8	IO307NB5F34	AP6
IO272PB5F31	AJ17	IO290NB5F32	AH13	IO307PB5F34	AP7
IO273NB5F31	AL16	IO290PB5F32	AH14	IO308NB5F34	AK9
IO273PB5F31	AM16	IO291NB5F32	AR9	IO308PB5F34	AL9
IO274NB5F31	AH15	IO291PB5F32	AR10	IO309NB5F34	AR6
IO274PB5F31	AH16	IO292NB5F32	AJ12	IO309PB5F34	AR7
IO275NB5F31	AR15	IO292PB5F32	AJ13	IO310NB5F34	AH9
IO275PB5F31	AR16	IO293NB5F33	AP12	IO310PB5F34	AH10
IO276NB5F31	AJ14	IO293PB5F33	AP13	IO311NB5F34	AM8
IO276PB5F31	AJ15	IO294NB5F33	AG13	IO311PB5F34	AM7

CG1272/LG1272	
RTAX4000S/SL Function	Pin Number
IO312NB5F34	AG9
IO312PB5F34	AG8
IO313NB5F34	AN7
IO313PB5F34	AN8
Bank 6	
IO314NB6F36	AF8
IO314PB6F36	AF9
IO315NB6F36	AN2
IO315PB6F36	AN3
IO316NB6F36	AH4
IO316PB6F36	AJ4
IO317NB6F36	AL3
IO317PB6F36	AL4
IO318NB6F36	AK4
IO318PB6F36	AK5
IO319NB6F36	AE10
IO319PB6F36	AE9
IO320NB6F36	AG4
IO320PB6F36	AG5
IO321NB6F36	AE11
IO321PB6F36	AD11
IO322NB6F37	AG3
IO322PB6F37	AH3
IO323NB6F37	AG7
IO323PB6F37	AG6
IO324NB6F37	AH7
IO324PB6F37	AH6
IO325NB6F37	AJ5
IO325PB6F37	AH5
IO326NB6F37	AK2
IO326PB6F37	AK3
IO327NB6F37	AE7
IO327PB6F37	AE8
IO328NB6F37	AM4
IO328PB6F37	AN4

CG1272/LG1272	
RTAX4000S/SL Function	Pin Number
IO329NB6F37	AD9
IO329PB6F37	AD10
IO330NB6F37	AM1
IO330PB6F37	AN1
IO331NB6F38	AE5
IO331PB6F38	AE6
IO332NB6F38	AF4
IO332PB6F38	AF5
IO333NB6F38	AD8
IO333PB6F38	AD7
IO334NB6F38	AG2
IO334PB6F38	AH2
IO335NB6F38	AC12
IO335PB6F38	AD12
IO336NB6F38	AJ1
IO336PB6F38	AK1
IO337NB6F38	AC8
IO337PB6F38	AC9
IO338NB6F38	AD3
IO338PB6F38	AE3
IO339NB6F38	AD5
IO339PB6F38	AD6
IO340NB6F39	AD4
IO340PB6F39	AE4
IO341NB6F39	AB8
IO341PB6F39	AB9
IO342NB6F39	AG1
IO342PB6F39	AH1
IO343NB6F39	AA12
IO343PB6F39	AB12
IO344NB6F39	AD2
IO344PB6F39	AE2
IO345NB6F39	AA11
IO345PB6F39	AB11
IO346NB6F39	AE1

CG1272/LG1272	
RTAX4000S/SL Function	Pin Number
IO346PB6F39	AF1
IO347NB6F39	AL1
IO347PB6F39	AL2
IO348NB6F39	AC4
IO348PB6F39	AC5
IO349NB6F40	AB6
IO349PB6F40	AB7
IO350NB6F40	AC1
IO350PB6F40	AD1
IO351NB6F40	AA9
IO351PB6F40	AA10
IO352NB6F40	AB2
IO352PB6F40	AB3
IO353NB6F40	AA7
IO353PB6F40	AA8
IO354NB6F40	AA2
IO354PB6F40	AA3
IO355NB6F40	AA5
IO355PB6F40	AA6
IO356NB6F40	AB4
IO356PB6F40	AB5
IO357NB6F40	W12
IO357PB6F40	Y12
IO358NB6F41	AA1
IO358PB6F41	AB1
IO359NB6F41	Y8
IO359PB6F41	Y9
IO360NB6F41	Y4
IO360PB6F41	AA4
IO361NB6F41	U12
IO361PB6F41	V12
IO362NB6F41	W1
IO362PB6F41	Y1
IO363NB6F41	W6
IO363PB6F41	W7

CG1272/LG1272		CG1272/LG1272		CG1272/LG1272	
RTAX4000S/SL Function	Pin Number	RTAX4000S/SL Function	Pin Number	RTAX4000S/SL Function	Pin Number
IO364NB6F41	W5	IO381NB7F43	R6	IO398PB7F45	K2
IO364PB6F41	Y5	IO381PB7F43	R7	IO399NB7F45	N8
IO365NB6F41	W10	IO382NB7F43	N1	IO399PB7F45	N7
IO365PB6F41	W9	IO382PB7F43	P1	IO400NB7F45	G1
IO366NB6F41	V2	IO383NB7F43	T10	IO400PB7F45	H1
IO366PB6F41	W2	IO383PB7F43	T9	IO401NB7F45	M5
Bank 7		IO384NB7F43	R3	IO401PB7F45	M6
IO367NB7F42	V8	IO384PB7F43	R2	IO402NB7F45	E1
IO367PB7F42	W8	IO385NB7F44	R12	IO402PB7F45	F1
IO368NB7F42	V3	IO385PB7F44	R11	IO403NB7F46	N10
IO368PB7F42	W3	IO386NB7F44	L1	IO403PB7F46	N9
IO369NB7F42	V9	IO386PB7F44	M1	IO404NB7F46	L5
IO369PB7F42	V10	IO387NB7F44	G2	IO404PB7F46	L4
IO370NB7F42	U1	IO387PB7F44	F2	IO405NB7F46	M7
IO370PB7F42	V1	IO388NB7F44	P5	IO405PB7F46	M8
IO371NB7F42	V7	IO388PB7F44	P4	IO406NB7F46	G3
IO371PB7F42	V6	IO389NB7F44	R8	IO406PB7F46	F3
IO372NB7F42	U5	IO389PB7F44	R9	IO407NB7F46	M10
IO372PB7F42	V5	IO390NB7F44	J1	IO407PB7F46	M9
IO373NB7F42	U9	IO390PB7F44	K1	IO408NB7F46	D4
IO373PB7F42	U8	IO391NB7F44	N12	IO408PB7F46	D3
IO374NB7F42	R1	IO391PB7F44	P12	IO409NB7F46	J7
IO374PB7F42	T1	IO392NB7F44	M2	IO409PB7F46	J6
IO375NB7F42	T11	IO392PB7F44	N2	IO410NB7F46	J3
IO375PB7F42	T12	IO393NB7F44	P9	IO410PB7F46	K3
IO376NB7F43	T4	IO393PB7F44	P8	IO411NB7F46	L8
IO376PB7F43	U4	IO394NB7F45	M3	IO411PB7F46	L9
IO377NB7F43	T8	IO394PB7F45	N3	IO412NB7F47	K5
IO377PB7F43	T7	IO395NB7F45	M11	IO412PB7F47	K4
IO378NB7F43	T3	IO395PB7F45	N11	IO413NB7F47	K7
IO378PB7F43	T2	IO396NB7F45	M4	IO413PB7F47	K6
IO379NB7F43	T5	IO396PB7F45	N4	IO414NB7F47	E4
IO379PB7F43	T6	IO397NB7F45	N5	IO414PB7F47	F4
IO380NB7F43	R5	IO397PB7F45	N6	IO415NB7F47	G4
IO380PB7F43	R4	IO398NB7F45	J2	IO415PB7F47	G5

CG1272/LG1272	
RTAX4000S/SL Function	Pin Number
IO416NB7F47	H4
IO416PB7F47	J4
IO417NB7F47	D2
IO417PB7F47	D1
IO418NB7F47	K8
IO418PB7F47	K9
IO419NB7F47	H5
IO419PB7F47	J5
Dedicated I/O	
GND	J8
GND	AA13
GND	AA15
GND	AA17
GND	AA19
GND	AA21
GND	AA23
GND	AA24
GND	AB14
GND	AB16
GND	AB18
GND	AB20
GND	AB22
GND	AC11
GND	AC13
GND	AC15
GND	AC17
GND	AC19
GND	AC21
GND	AC23
GND	AC24
GND	AC26
GND	AC3
GND	AC30
GND	AC34
GND	AC7

CG1272/LG1272	
RTAX4000S/SL Function	Pin Number
GND	AD13
GND	AD14
GND	AD16
GND	AD18
GND	AD19
GND	AD21
GND	AD23
GND	AD24
GND	AE15
GND	AE25
GND	AF10
GND	AF11
GND	AF14
GND	AF17
GND	AF20
GND	AF23
GND	AF26
GND	AF27
GND	AF3
GND	AF30
GND	AF34
GND	AF7
GND	AJ29
GND	AJ3
GND	AJ30
GND	AJ34
GND	AJ7
GND	AK11
GND	AK14
GND	AK17
GND	AK20
GND	AK23
GND	AK26
GND	AK29
GND	AK6

CG1272/LG1272	
RTAX4000S/SL Function	Pin Number
GND	AK8
GND	AL18
GND	AL31
GND	AL7
GND	AM3
GND	AM34
GND	AP11
GND	AP14
GND	AP17
GND	AP2
GND	AP20
GND	AP23
GND	AP26
GND	AP29
GND	AP32
GND	AP35
GND	AP5
GND	AP8
GND	AR3
GND	AR34
GND	B3
GND	B34
GND	C11
GND	C14
GND	C17
GND	C2
GND	C20
GND	C23
GND	C26
GND	C29
GND	C32
GND	C35
GND	C5
GND	C8
GND	E3

CG1272/LG1272		CG1272/LG1272		CG1272/LG1272	
RTAX4000S/SL Function	Pin Number	RTAX4000S/SL Function	Pin Number	RTAX4000S/SL Function	Pin Number
GND	E34	GND	N23	GND	U3
GND	F30	GND	N24	GND	U30
GND	F7	GND	P11	GND	U34
GND	G11	GND	P13	GND	U7
GND	G14	GND	P14	GND	V13
GND	G17	GND	P16	GND	V14
GND	G20	GND	P18	GND	V16
GND	G23	GND	P20	GND	V18
GND	G26	GND	P22	GND	V20
GND	G29	GND	P24	GND	V22
GND	G8	GND	P26	GND	V24
GND	H3	GND	P3	GND	V33
GND	H30	GND	P30	GND	V4
GND	H34	GND	P34	GND	W11
GND	H7	GND	P7	GND	W13
GND	J31	GND	R15	GND	W15
GND	L10	GND	R17	GND	W17
GND	L11	GND	R19	GND	W19
GND	L14	GND	R21	GND	W21
GND	L17	GND	R23	GND	W23
GND	L20	GND	R27	GND	W24
GND	L23	GND	T13	GND	W26
GND	L26	GND	T14	GND	W4
GND	L27	GND	T16	GND	Y11
GND	L3	GND	T18	GND	Y14
GND	L30	GND	T20	GND	Y16
GND	L34	GND	T22	GND	Y18
GND	L7	GND	T24	GND	Y20
GND	M15	GND	U11	GND	Y22
GND	M25	GND	U15	GND	Y26
GND	N14	GND	U17	GND	Y3
GND	N16	GND	U19	GND	Y30
GND	N18	GND	U21	GND	Y34
GND	N19	GND	U23	GND	Y7
GND	N21	GND	U26	NC	AJ8

CG1272/LG1272		CG1272/LG1272		CG1272/LG1272	
RTAX4000S/SL Function	Pin Number	RTAX4000S/SL Function	Pin Number	RTAX4000S/SL Function	Pin Number
NC	W36	VCCA	M12	VCCA	Y21
PRA	F18	VCCA	P15	VCCA	Y23
PRB	A18	VCCA	P17	VCCDA	AB10
PRC	AL19	VCCA	P19	VCCDA	AB27
PRD	AT19	VCCA	P21	VCCDA	AE22
TCK	H8	VCCA	P23	VCCDA	AF18
TDI	F6	VCCA	R14	VCCDA	AF19
TDO	H9	VCCA	R16	VCCDA	AH29
TMS	F5	VCCA	R18	VCCDA	AH8
TRST	G7	VCCA	R20	VCCDA	AJ28
VCCA	A19	VCCA	R22	VCCDA	AJ9
VCCA	AA14	VCCA	T15	VCCDA	AK30
VCCA	AA16	VCCA	T17	VCCDA	AK7
VCCA	AA18	VCCA	T19	VCCDA	AL30
VCCA	AA20	VCCA	T21	VCCDA	AL6
VCCA	AA22	VCCA	T23	VCCDA	AM13
VCCA	AB15	VCCA	U14	VCCDA	AM24
VCCA	AB17	VCCA	U16	VCCDA	AM31
VCCA	AB19	VCCA	U18	VCCDA	AM32
VCCA	AB21	VCCA	U20	VCCDA	AM5
VCCA	AB23	VCCA	U22	VCCDA	AM6
VCCA	AC14	VCCA	V15	VCCDA	AN16
VCCA	AC16	VCCA	V17	VCCDA	AN21
VCCA	AC18	VCCA	V19	VCCDA	AP16
VCCA	AC20	VCCA	V21	VCCDA	AP21
VCCA	AC22	VCCA	V23	VCCDA	C16
VCCA	AE12	VCCA	W14	VCCDA	C21
VCCA	AL32	VCCA	W16	VCCDA	D16
VCCA	AL5	VCCA	W18	VCCDA	D21
VCCA	AP3	VCCA	W20	VCCDA	E13
VCCA	AP34	VCCA	W22	VCCDA	E24
VCCA	AT18	VCCA	W33	VCCDA	E5
VCCA	C3	VCCA	Y15	VCCDA	E6
VCCA	C34	VCCA	Y17	VCCDA	F19
VCCA	J30	VCCA	Y19	VCCDA	F31

CG1272/LG1272		CG1272/LG1272		CG1272/LG1272	
RTAX4000S/SL Function	Pin Number	RTAX4000S/SL Function	Pin Number	RTAX4000S/SL Function	Pin Number
VCCDA	G30	VCCIB1	F29	VCCIB4	AD22
VCCDA	G31	VCCIB1	K20	VCCIB4	AG20
VCCDA	G6	VCCIB1	K23	VCCIB4	AG23
VCCDA	H28	VCCIB1	K26	VCCIB4	AG26
VCCDA	H29	VCCIB1	N20	VCCIB4	AL20
VCCDA	J29	VCCIB1	N22	VCCIB4	AL23
VCCDA	L18	VCCIB2	E35	VCCIB4	AL26
VCCDA	L19	VCCIB2	H31	VCCIB4	AL29
VCCDA	M22	VCCIB2	H35	VCCIB4	AR20
VCCDA	N13	VCCIB2	K27	VCCIB4	AR23
VCCDA	R10	VCCIB2	L31	VCCIB4	AR26
VCCDA	V11	VCCIB2	L35	VCCIB4	AR29
VCCDA	V26	VCCIB2	P27	VCCIB4	AR32
VCCIB0	B11	VCCIB2	P31	VCCIB5	AD15
VCCIB0	B14	VCCIB2	P35	VCCIB5	AD17
VCCIB0	B17	VCCIB2	R24	VCCIB5	AG11
VCCIB0	B5	VCCIB2	U24	VCCIB5	AG14
VCCIB0	B8	VCCIB2	U27	VCCIB5	AG17
VCCIB0	F11	VCCIB2	U31	VCCIB5	AL11
VCCIB0	F14	VCCIB2	U35	VCCIB5	AL14
VCCIB0	F17	VCCIB3	AB24	VCCIB5	AL17
VCCIB0	F8	VCCIB3	AC27	VCCIB5	AL8
VCCIB0	K11	VCCIB3	AC31	VCCIB5	AR11
VCCIB0	K14	VCCIB3	AC35	VCCIB5	AR14
VCCIB0	K17	VCCIB3	AF31	VCCIB5	AR17
VCCIB0	N15	VCCIB3	AF35	VCCIB5	AR5
VCCIB0	N17	VCCIB3	AG27	VCCIB5	AR8
VCCIB1	B20	VCCIB3	AJ31	VCCIB6	AB13
VCCIB1	B23	VCCIB3	AJ35	VCCIB6	AC10
VCCIB1	B26	VCCIB3	AM35	VCCIB6	AC2
VCCIB1	B29	VCCIB3	Y24	VCCIB6	AC6
VCCIB1	B32	VCCIB3	Y27	VCCIB6	AF2
VCCIB1	F20	VCCIB3	Y31	VCCIB6	AF6
VCCIB1	F23	VCCIB3	Y35	VCCIB6	AG10
VCCIB1	F26	VCCIB4	AD20	VCCIB6	AJ2

CG1272/LG1272	
RTAX4000S/SL Function	Pin Number
VCCIB6	AJ6
VCCIB6	AM2
VCCIB6	Y10
VCCIB6	Y13
VCCIB6	Y2
VCCIB6	Y6
VCCIB7	E2
VCCIB7	H2
VCCIB7	H6
VCCIB7	K10
VCCIB7	L2
VCCIB7	L6
VCCIB7	P10
VCCIB7	P2
VCCIB7	P6
VCCIB7	R13
VCCIB7	U10
VCCIB7	U13
VCCIB7	U2
VCCIB7	U6
VPUMP	F32

CG1272/LG1272		CG1272/LG1272		CG1272/LG1272	
RTAX2000D Function	Pin Number	RTAX2000D Function	Pin Number	RTAX2000D Function	Pin Number
Bank 0		IO17PB0F1	F13	IO35PB0F3	M19
IO00NB0F0	F10	IO18NB0F1	D14	IO36NB0F3	A13
IO00PB0F0	G10	IO18PB0F1	D13	IO36PB0F3	A12
IO01NB0F0	E7	IO19NB0F1	K15	IO37NB0F3	G18
IO01PB0F0	E8	IO19PB0F1	K16	IO37PB0F3	H18
IO02NB0F0	E9	IO20NB0F1	A11	IO38NB0F3	A17
IO02PB0F0	D9	IO20PB0F1	A10	IO38PB0F3	A16
IO03NB0F0	J12	IO21NB0F1	H15	IO39NB0F3	M16
IO03PB0F0	J11	IO21PB0F1	H14	IO39PB0F3	M17
IO04NB0F0	A7	IO22NB0F2	B7	IO40NB0F3	C18
IO04PB0F0	A6	IO22PB0F2	B6	IO40PB0F3	B18
IO05NB0F0	J10	IO23NB0F2	A8	IO41NB0F3/HCLKAN	J18
IO05PB0F0	J9	IO23PB0F2	A9	IO41PB0F3/HCLKAP	K18
IO06NB0F0	C7	IO24NB0F2	B13	IO42NB0F3/HCLKBN	D18
IO06PB0F0	C6	IO24PB0F2	B12	IO42PB0F3/HCLKBP	D17
IO07NB0F0	E12	IO25NB0F2	J16	Bank 1	
IO07PB0F0	E11	IO25PB0F2	J15	IO43NB1F4/HCLKCN	K19
IO08NB0F0	C10	IO26NB0F2	G15	IO43PB1F4/HCLKCP	J19
IO08PB0F0	C9	IO26PB0F2	F15	IO44NB1F4/HCLKDN	D20
IO09NB0F0	H13	IO27NB0F2	E15	IO44PB1F4/HCLKDP	D19
IO09PB0F0	H12	IO27PB0F2	E14	IO45NB1F4	H19
IO10NB0F0	B4	IO28NB0F2	C15	IO45PB1F4	G19
IO10PB0F0	C4	IO28PB0F2	D15	IO46NB1F4	A21
IO11NB0F0	L13	IO29NB0F2	E18	IO46PB1F4	A20
IO11PB0F0	L12	IO29PB0F2	E17	IO47NB1F4	M20
IO12NB0F1	F12	IO30NB0F2	C13	IO47PB1F4	M21
IO12PB0F1	G12	IO30PB0F2	C12	IO48NB1F4	B19
IO13NB0F1	J14	IO31NB0F2	G16	IO48PB1F4	C19
IO13PB0F1	J13	IO31PB0F2	H16	IO49NB1F4	F22
IO14NB0F1	A5	IO32NB0F2	A14	IO49PB1F4	G22
IO14PB0F1	A4	IO32PB0F2	A15	IO50NB1F4	F21
IO15NB0F1	D12	IO33NB0F2	L16	IO50PB1F4	E21
IO15PB0F1	D11	IO33PB0F2	L15	IO51NB1F4	L22
IO16NB0F1	B10	IO34NB0F3	E16	IO51PB1F4	L21
IO16PB0F1	B9	IO34PB0F3	F16	IO52NB1F4	D22
IO17NB0F1	G13	IO35NB0F3	M18	IO52PB1F4	C22

CG1272/LG1272	
RTAX2000D Function	Pin Number
IO53NB1F4	K22
IO53PB1F4	K21
IO54NB1F5	A22
IO54PB1F5	A23
IO55NB1F5	E20
IO55PB1F5	E19
IO56NB1F5	B22
IO56PB1F5	B21
IO57NB1F5	E23
IO57PB1F5	E22
IO58NB1F5	A25
IO58PB1F5	A24
IO59NB1F5	M24
IO59PB1F5	M23
IO60NB1F5	C28
IO60PB1F5	C27
IO61NB1F5	H23
IO61PB1F5	H22
IO62NB1F5	D24
IO62PB1F5	D23
IO63NB1F5	D26
IO63PB1F5	D25
IO64NB1F6	B25
IO64PB1F6	B24
IO65NB1F6	E27
IO65PB1F6	D27
IO66NB1F6	A27
IO66PB1F6	A26
IO67NB1F6	F24
IO67PB1F6	G24
IO68NB1F6	B28
IO68PB1F6	B27
IO69NB1F6	L24
IO69PB1F6	L25
IO70NB1F6	A28
IO70PB1F6	A29

CG1272/LG1272	
RTAX2000D Function	Pin Number
IO71NB1F6	E29
IO71PB1F6	E30
IO72NB1F6	B31
IO72PB1F6	B30
IO73NB1F6	E26
IO73PB1F6	E25
IO74NB1F6	A31
IO74PB1F6	A30
IO75NB1F6	K25
IO75PB1F6	K24
IO76NB1F7	D30
IO76PB1F7	D29
IO77NB1F7	G27
IO77PB1F7	F27
IO78NB1F7	A33
IO78PB1F7	A32
IO79NB1F7	J26
IO79PB1F7	J25
IO80NB1F7	D32
IO80PB1F7	D31
IO81NB1F7	H27
IO81PB1F7	H26
IO82NB1F7	C33
IO82PB1F7	B33
IO83NB1F7	F28
IO83PB1F7	G28
IO84NB1F7	D28
IO84PB1F7	E28
IO85NB1F7	E31
IO85PB1F7	E32
Bank 2	
IO86NB2F8	K31
IO86PB2F8	K30
IO87NB2F8	L29
IO87PB2F8	L28
IO88NB2F8	E33

CG1272/LG1272	
RTAX2000D Function	Pin Number
IO88PB2F8	D33
IO89NB2F8	G33
IO89PB2F8	G32
IO90NB2F8	F35
IO90PB2F8	F36
IO91NB2F8	L33
IO91PB2F8	L32
IO92NB2F8	H32
IO92PB2F8	J32
IO93NB2F8	M32
IO93PB2F8	M31
IO94NB2F8	H36
IO94PB2F8	G36
IO95NB2F8	M28
IO95PB2F8	M27
IO96NB2F9	F34
IO96PB2F9	F33
IO97NB2F9	N30
IO97PB2F9	N29
IO98NB2F9	K33
IO98PB2F9	K32
IO99NB2F9	P29
IO99PB2F9	P28
IO100NB2F9	H33
IO100PB2F9	J33
IO101NB2F9	P33
IO101PB2F9	P32
IO102NB2F9	K36
IO102PB2F9	J36
IO103NB2F9	R29
IO103PB2F9	R28
IO104NB2F9	E36
IO104PB2F9	D36
IO105NB2F9	R31
IO105PB2F9	R30
IO106NB2F9	N34

CG1272/LG1272		CG1272/LG1272		CG1272/LG1272	
RTAX2000D Function	Pin Number	RTAX2000D Function	Pin Number	RTAX2000D Function	Pin Number
IO106PB2F9	M34	IO124PB2F11	U32	IO142NB3F13	AE36
IO107NB2F10	R33	IO125NB2F11	V25	IO142PB3F13	AD36
IO107PB2F10	R32	IO125PB2F11	U25	IO143NB3F13	AA27
IO108NB2F10	K35	IO126NB2F11	V36	IO143PB3F13	AA28
IO108PB2F10	J35	IO126PB2F11	U36	IO144NB3F13	Y32
IO109NB2F10	T28	IO127NB2F11	V27	IO144PB3F13	W32
IO109PB2F10	T27	IO127PB2F11	V28	IO145NB3F13	AB25
IO110NB2F10	R35	IO128NB2F11	W34	IO145PB3F13	AB26
IO110PB2F10	R34	IO128PB2F11	V34	IO146NB3F13	AE34
IO111NB2F10	N28	Bank 3		IO146PB3F13	AD34
IO111PB2F10	N27	IO129NB3F12	AH33	IO147NB3F13	AB31
IO112NB2F10	N35	IO129PB3F12	AJ33	IO147PB3F13	AB30
IO112PB2F10	M35	IO130NB3F12	AA36	IO148NB3F13	AE35
IO113NB2F10	T32	IO130PB3F12	Y36	IO148PB3F13	AD35
IO113PB2F10	T31	IO131NB3F12	W30	IO149NB3F13	AF32
IO114NB2F10	M36	IO131PB3F12	W31	IO149PB3F13	AF33
IO114PB2F10	L36	IO132NB3F12	W35	IO150NB3F14	AG36
IO115NB2F10	T30	IO132PB3F12	V35	IO150PB3F14	AF36
IO115PB2F10	T29	IO133NB3F12	W27	IO151NB3F14	AC32
IO116NB2F10	U33	IO133PB3F12	W28	IO151PB3F14	AC33
IO116PB2F10	T33	IO134NB3F12	AC36	IO152NB3F14	AH34
IO117NB2F10	R26	IO134PB3F12	AB36	IO152PB3F14	AG34
IO117PB2F10	R25	IO135NB3F12	AA26	IO153NB3F14	AC29
IO118NB2F11	P36	IO135PB3F12	AA25	IO153PB3F14	AC28
IO118PB2F11	N36	IO136NB3F12	AA34	IO154NB3F14	AJ36
IO119NB2F11	U29	IO136PB3F12	AA35	IO154PB3F14	AH36
IO119PB2F11	U28	IO137NB3F12	Y28	IO155NB3F14	AJ32
IO120NB2F11	T35	IO137PB3F12	Y29	IO155PB3F14	AH32
IO120PB2F11	T34	IO138NB3F12	AA33	IO156NB3F14	AH35
IO121NB2F11	T26	IO138PB3F12	Y33	IO156PB3F14	AG35
IO121PB2F11	T25	IO139NB3F13	AB32	IO157NB3F14	AE26
IO122NB2F11	T36	IO139PB3F13	AB33	IO157PB3F14	AD26
IO122PB2F11	R36	IO140NB3F13	AB34	IO158NB3F14	AG32
IO123NB2F11	V31	IO140PB3F13	AB35	IO158PB3F14	AG33
IO123PB2F11	V30	IO141NB3F13	AA32	IO159NB3F14	AD32
IO124NB2F11	V32	IO141PB3F13	AA31	IO159PB3F14	AD31

CG1272/LG1272	
RTAX2000D Function	Pin Number
IO160NB3F14	AK35
IO160PB3F14	AK36
IO161NB3F15	AC25
IO161PB3F15	AD25
IO162NB3F15	AL35
IO162PB3F15	AL36
IO163NB3F15	AE32
IO163PB3F15	AE31
IO164NB3F15	AN33
IO164PB3F15	AM33
IO165NB3F15	AD27
IO165PB3F15	AD28
IO166NB3F15	AN36
IO166PB3F15	AM36
IO167NB3F15	AF29
IO167PB3F15	AF28
IO168NB3F15	AN34
IO168PB3F15	AN35
IO169NB3F15	AK32
IO169PB3F15	AK31
IO170NB3F15	AG31
IO170PB3F15	AG30
Bank 4	
IO171NB4F16	AN31
IO171PB4F16	AN32
IO172NB4F16	AJ26
IO172PB4F16	AJ27
IO173NB4F16	AR33
IO173PB4F16	AP33
IO174NB4F16	AL28
IO174PB4F16	AK28
IO175NB4F16	AT30
IO175PB4F16	AT31
IO176NB4F16	AH25
IO176PB4F16	AH26
IO177NB4F16	AM30

CG1272/LG1272	
RTAX2000D Function	Pin Number
IO177PB4F16	AM29
IO178NB4F16	AH27
IO178PB4F16	AH28
IO179NB4F16	AT29
IO179PB4F16	AT28
IO180NB4F16	AF24
IO180PB4F16	AF25
IO181NB4F17	AT32
IO181PB4F17	AT33
IO182NB4F17	AK24
IO182PB4F17	AL24
IO183NB4F17	AM25
IO183PB4F17	AM26
IO184NB4F17	AG25
IO184PB4F17	AG24
IO185NB4F17	AN29
IO185PB4F17	AN30
IO186NB4F17	AL25
IO186PB4F17	AK25
IO187NB4F17	AR30
IO187PB4F17	AR31
IO188NB4F17	AF21
IO188PB4F17	AF22
IO189NB4F17	AT26
IO189PB4F17	AT27
IO190NB4F17	AE23
IO190PB4F17	AE24
IO191NB4F17	AN25
IO191PB4F17	AN26
IO192NB4F17	AJ22
IO192PB4F17	AJ23
IO193NB4F18	AN23
IO193PB4F18	AN24
IO194NB4F18	AL27
IO194PB4F18	AK27
IO195NB4F18	AP27

CG1272/LG1272	
RTAX2000D Function	Pin Number
IO195PB4F18	AP28
IO196NB4F18	AG21
IO196PB4F18	AG22
IO197NB4F18	AT24
IO197PB4F18	AT25
IO198NB4F18	AH21
IO198PB4F18	AH22
IO199NB4F18	AP24
IO199PB4F18	AP25
IO200NB4F18	AK22
IO200PB4F18	AL22
IO201NB4F18	AP22
IO201PB4F18	AN22
IO202NB4F18	AM22
IO202PB4F18	AM23
IO203NB4F19	AR27
IO203PB4F19	AR28
IO204NB4F19	AM21
IO204PB4F19	AL21
IO205NB4F19	AT23
IO205PB4F19	AT22
IO206NB4F19	AE21
IO206PB4F19	AE20
IO207NB4F19	AR24
IO207PB4F19	AR25
IO208NB4F19	AM19
IO208PB4F19	AM20
IO209NB4F19	AT20
IO209PB4F19	AT21
IO210NB4F19	AH20
IO210PB4F19	AJ20
IO211NB4F19	AP19
IO211PB4F19	AR19
IO212NB4F19/CLKEN	AH19
IO212PB4F19/CLKEP	AG19
IO213NB4F19/CLKFN	AN19

CG1272/LG1272		CG1272/LG1272		CG1272/LG1272	
RTAX2000D Function	Pin Number	RTAX2000D Function	Pin Number	RTAX2000D Function	Pin Number
IO213PB4F19/CLKFP	AN20	IO231NB5F21	AP12	IO249NB5F23	AT10
Bank 5		IO231PB5F21	AP13	IO249PB5F23	AT11
IO214NB5F20/CLKGN	AG18	IO232NB5F21	AF16	IO250NB5F23	AG12
IO214PB5F20/CLKGP	AH18	IO232PB5F21	AF15	IO250PB5F23	AF12
IO215NB5F20/CLKHN	AN17	IO233NB5F21	AN13	IO251NB5F23	AR6
IO215PB5F20/CLKHP	AN18	IO233PB5F21	AN14	IO251PB5F23	AR7
IO216NB5F20	AJ18	IO234NB5F21	AJ14	IO252NB5F23	AP4
IO216PB5F20	AK18	IO234PB5F21	AJ15	IO252PB5F23	AR4
IO217NB5F20	AR18	IO235NB5F22	AR9	IO253NB5F23	AT6
IO217PB5F20	AP18	IO235PB5F22	AR10	IO253PB5F23	AT7
IO218NB5F20	AH17	IO236NB5F22	AG13	IO254NB5F23	AJ10
IO218PB5F20	AJ17	IO236PB5F22	AF13	IO254PB5F23	AJ11
IO219NB5F20	AT16	IO237NB5F22	AP9	IO255NB5F23	AK9
IO219PB5F20	AT17	IO237PB5F22	AP10	IO255PB5F23	AL9
IO220NB5F20	AM17	IO238NB5F22	AM8	IO256NB5F23	AH9
IO220PB5F20	AM18	IO238PB5F22	AM7	IO256PB5F23	AH10
IO221NB5F20	AR15	IO239NB5F22	AM11	Bank 6	
IO221PB5F20	AR16	IO239PB5F22	AM12	IO257NB6F24	AH7
IO222NB5F20	AL16	IO240NB5F22	AH11	IO257PB6F24	AH6
IO222PB5F20	AM16	IO240PB5F22	AH12	IO258NB6F24	AG7
IO223NB5F21	AR12	IO241NB5F22	AT12	IO258PB6F24	AG6
IO223PB5F21	AR13	IO241PB5F22	AT13	IO259NB6F24	AN2
IO224NB5F21	AE17	IO242NB5F22	AE13	IO259PB6F24	AN3
IO224PB5F21	AE16	IO242PB5F22	AE14	IO260NB6F24	AE7
IO225NB5F21	AT9	IO243NB5F22	AM10	IO260PB6F24	AE8
IO225PB5F21	AT8	IO243PB5F22	AN10	IO261NB6F24	AJ1
IO226NB5F21	AG15	IO244NB5F22	AN9	IO261PB6F24	AK1
IO226PB5F21	AG16	IO244PB5F22	AM9	IO262NB6F24	AE10
IO227NB5F21	AH15	IO245NB5F23	AN7	IO262PB6F24	AE9
IO227PB5F21	AH16	IO245PB5F23	AN8	IO263NB6F24	AM4
IO228NB5F21	AM14	IO246NB5F23	AK12	IO263PB6F24	AN4
IO228PB5F21	AM15	IO246PB5F23	AL12	IO264NB6F24	AE5
IO229NB5F21	AN15	IO247NB5F23	AN5	IO264PB6F24	AE6
IO229PB5F21	AP15	IO247PB5F23	AN6	IO265NB6F24	AG1
IO230NB5F21	AL15	IO248NB5F23	AJ12	IO265PB6F24	AH1
IO230PB5F21	AK15	IO248PB5F23	AJ13	IO266NB6F24	AD8

CG1272/LG1272	
RTAX2000D Function	Pin Number
IO266PB6F24	AD7
IO267NB6F25	AM1
IO267PB6F25	AN1
IO268NB6F25	AD5
IO268PB6F25	AD6
IO269NB6F25	AF4
IO269PB6F25	AF5
IO270NB6F25	AD9
IO270PB6F25	AD10
IO271NB6F25	AJ5
IO271PB6F25	AH5
IO272NB6F25	AF8
IO272PB6F25	AF9
IO273NB6F25	AE1
IO273PB6F25	AF1
IO274NB6F25	AB6
IO274PB6F25	AB7
IO275NB6F25	AL1
IO275PB6F25	AL2
IO276NB6F25	AA11
IO276PB6F25	AB11
IO277NB6F25	AK4
IO277PB6F25	AK5
IO278NB6F26	AC4
IO278PB6F26	AC5
IO279NB6F26	AG3
IO279PB6F26	AH3
IO280NB6F26	AE11
IO280PB6F26	AD11
IO281NB6F26	AC1
IO281PB6F26	AD1
IO282NB6F26	AA7
IO282PB6F26	AA8
IO283NB6F26	AK2
IO283PB6F26	AK3
IO284NB6F26	AC12

CG1272/LG1272	
RTAX2000D Function	Pin Number
IO284PB6F26	AD12
IO285NB6F26	AB2
IO285PB6F26	AB3
IO286NB6F26	AD3
IO286PB6F26	AE3
IO287NB6F26	AG2
IO287PB6F26	AH2
IO288NB6F26	Y8
IO288PB6F26	Y9
IO289NB6F27	AA1
IO289PB6F27	AB1
IO290NB6F27	AA12
IO290PB6F27	AB12
IO291NB6F27	AA5
IO291PB6F27	AA6
IO292NB6F27	AB4
IO292PB6F27	AB5
IO293NB6F27	AA2
IO293PB6F27	AA3
IO294NB6F27	W12
IO294PB6F27	Y12
IO295NB6F27	AD2
IO295PB6F27	AE2
IO296NB6F27	W10
IO296PB6F27	W9
IO297NB6F27	W1
IO297PB6F27	Y1
IO298NB6F27	W5
IO298PB6F27	Y5
IO299NB6F27	V2
IO299PB6F27	W2
Bank 7	
IO300NB7F28	V9
IO300PB7F28	V10
IO301NB7F28	U1
IO301PB7F28	V1

CG1272/LG1272	
RTAX2000D Function	Pin Number
IO302NB7F28	R12
IO302PB7F28	R11
IO303NB7F28	T3
IO303PB7F28	T2
IO304NB7F28	U5
IO304PB7F28	V5
IO305NB7F28	N1
IO305PB7F28	P1
IO306NB7F28	N12
IO306PB7F28	P12
IO307NB7F28	R3
IO307PB7F28	R2
IO308NB7F28	T10
IO308PB7F28	T9
IO309NB7F28	V3
IO309PB7F28	W3
IO310NB7F29	U9
IO310PB7F29	U8
IO311NB7F29	V7
IO311PB7F29	V6
IO312NB7F29	M11
IO312PB7F29	N11
IO313NB7F29	T4
IO313PB7F29	U4
IO314NB7F29	T11
IO314PB7F29	T12
IO315NB7F29	T5
IO315PB7F29	T6
IO316NB7F29	R5
IO316PB7F29	R4
IO317NB7F29	M2
IO317PB7F29	N2
IO318NB7F29	R8
IO318PB7F29	R9
IO319NB7F29	J2
IO319PB7F29	K2

CG1272/LG1272	
RTAX2000D Function	Pin Number
IO320NB7F29	R6
IO320PB7F29	R7
IO321NB7F30	M3
IO321PB7F30	N3
IO322NB7F30	N10
IO322PB7F30	N9
IO323NB7F30	P5
IO323PB7F30	P4
IO324NB7F30	M5
IO324PB7F30	M6
IO325NB7F30	L1
IO325PB7F30	M1
IO326NB7F30	N5
IO326PB7F30	N6
IO327NB7F30	G2
IO327PB7F30	F2
IO328NB7F30	L5
IO328PB7F30	L4
IO329NB7F30	G3
IO329PB7F30	F3
IO330NB7F30	M7
IO330PB7F30	M8
IO331NB7F30	H4
IO331PB7F30	J4
IO332NB7F31	K5
IO332PB7F31	K4
IO333NB7F31	J1
IO333PB7F31	K1
IO334NB7F31	H5
IO334PB7F31	J5
IO335NB7F31	E1
IO335PB7F31	F1
IO336NB7F31	M10
IO336PB7F31	M9
IO337NB7F31	G1
IO337PB7F31	H1

CG1272/LG1272	
RTAX2000D Function	Pin Number
IO338NB7F31	G4
IO338PB7F31	G5
IO339NB7F31	E4
IO339PB7F31	F4
IO340NB7F31	K8
IO340PB7F31	K9
IO341NB7F31	D4
IO341PB7F31	D3
Dedicated I/O	
GND	AA13
GND	AA15
GND	AA17
GND	AA19
GND	AA21
GND	AA23
GND	AA24
GND	AB14
GND	AB16
GND	AB18
GND	AB20
GND	AB22
GND	AC3
GND	AC7
GND	AC11
GND	AC13
GND	AC15
GND	AC17
GND	AC19
GND	AC21
GND	AC23
GND	AC24
GND	AC26
GND	AC30
GND	AC34
GND	AD14
GND	AD16

CG1272/LG1272	
RTAX2000D Function	Pin Number
GND	AD18
GND	AD19
GND	AD21
GND	AD23
GND	AF3
GND	AF7
GND	AF10
GND	AF11
GND	AF14
GND	AF17
GND	AF20
GND	AF23
GND	AF26
GND	AF27
GND	AF30
GND	AF34
GND	AJ3
GND	AJ7
GND	AJ29
GND	AJ30
GND	AJ34
GND	AK6
GND	AK8
GND	AK11
GND	AK14
GND	AK17
GND	AK20
GND	AK23
GND	AK26
GND	AK29
GND	AL7
GND	AL18
GND	AL31
GND	AM3
GND	AM34
GND	AP2

CG1272/LG1272	
RTAX2000D Function	Pin Number
GND	AP5
GND	AP8
GND	AP11
GND	AP14
GND	AP17
GND	AP20
GND	AP23
GND	AP26
GND	AP29
GND	AP32
GND	AP35
GND	AR3
GND	AR34
GND	B3
GND	B34
GND	C2
GND	C5
GND	C8
GND	C11
GND	C14
GND	C17
GND	C20
GND	C23
GND	C26
GND	C29
GND	C32
GND	C35
GND	E3
GND	E34
GND	F7
GND	F30
GND	G8
GND	G11
GND	G14
GND	G17
GND	G20

CG1272/LG1272	
RTAX2000D Function	Pin Number
GND	G23
GND	G26
GND	G29
GND	H3
GND	H7
GND	H30
GND	H34
GND	J8
GND	J31
GND	L3
GND	L7
GND	L10
GND	L11
GND	L14
GND	L17
GND	L20
GND	L23
GND	L26
GND	L27
GND	L30
GND	L34
GND	M15
GND	N14
GND	N16
GND	N18
GND	N19
GND	N21
GND	N23
GND	P3
GND	P7
GND	P11
GND	P13
GND	P14
GND	P16
GND	P18
GND	P20

CG1272/LG1272	
RTAX2000D Function	Pin Number
GND	P22
GND	P24
GND	P26
GND	P30
GND	P34
GND	R15
GND	R17
GND	R19
GND	R21
GND	R23
GND	T13
GND	T14
GND	T16
GND	T18
GND	T20
GND	T22
GND	T24
GND	U3
GND	U7
GND	U11
GND	U15
GND	U17
GND	U19
GND	U21
GND	U23
GND	U26
GND	U30
GND	U34
GND	V13
GND	V14
GND	V16
GND	V18
GND	V20
GND	V22
GND	V24
GND	V33

CG1272/LG1272		CG1272/LG1272		CG1272/LG1272	
RTAX2000D Function	Pin Number	RTAX2000D Function	Pin Number	RTAX2000D Function	Pin Number
GND	W4	NC	AD33	NC	AJ8
GND	W13	NC	AD4	NC	AK10
GND	W15	NC	AE12	NC	AK13
GND	W17	NC	AE15	NC	AK16
GND	W19	NC	AE18	NC	AK19
GND	W21	NC	AE19	NC	AK21
GND	W23	NC	AE22	NC	AK33
GND	W24	NC	AE25	NC	AK34
GND	Y3	NC	AE27	NC	AK7
GND	Y7	NC	AE28	NC	AL10
GND	Y11	NC	AE29	NC	AL13
GND	Y14	NC	AE30	NC	AL3
GND	Y16	NC	AE33	NC	AL30
GND	Y18	NC	AE4	NC	AL33
GND	Y20	NC	AG28	NC	AL34
GND	Y22	NC	AG29	NC	AL4
GND	Y26	NC	AG4	NC	AL6
GND	Y30	NC	AG5	NC	AM24
GND	Y34	NC	AG8	NC	AM27
NC	A19	NC	AG9	NC	AM28
NC	AA10	NC	AH13	NC	AM31
NC	AA29	NC	AH14	NC	AM5
NC	AA30	NC	AH23	NC	AN11
NC	AA4	NC	AH24	NC	AN12
NC	AA9	NC	AH29	NC	AN27
NC	AB10	NC	AH30	NC	AN28
NC	AB28	NC	AH31	NC	AP30
NC	AB29	NC	AH4	NC	AP31
NC	AB8	NC	AH8	NC	AP6
NC	AB9	NC	AJ16	NC	AP7
NC	AC8	NC	AJ19	NC	AR21
NC	AC9	NC	AJ21	NC	AR22
NC	AD13	NC	AJ24	NC	AT14
NC	AD24	NC	AJ25	NC	AT15
NC	AD29	NC	AJ28	NC	AT18
NC	AD30	NC	AJ4	NC	AT4

CG1272/LG1272	
RTAX2000D Function	Pin Number
NC	AT5
NC	B15
NC	B16
NC	C24
NC	C25
NC	C30
NC	C31
NC	D1
NC	D10
NC	D2
NC	D34
NC	D35
NC	D5
NC	D6
NC	D7
NC	D8
NC	E10
NC	E13
NC	E24
NC	E6
NC	F25
NC	F31
NC	F9
NC	G21
NC	G25
NC	G30
NC	G34
NC	G35
NC	G9
NC	H10
NC	H11
NC	H17
NC	H20
NC	H21
NC	H24
NC	H25

CG1272/LG1272	
RTAX2000D Function	Pin Number
NC	H29
NC	J17
NC	J20
NC	J21
NC	J22
NC	J23
NC	J24
NC	J27
NC	J28
NC	J29
NC	J3
NC	J34
NC	J6
NC	J7
NC	K12
NC	K13
NC	K28
NC	K29
NC	K3
NC	K34
NC	K6
NC	K7
NC	L18
NC	L8
NC	L9
NC	M13
NC	M14
NC	M25
NC	M26
NC	M29
NC	M30
NC	M33
NC	M4
NC	N13
NC	N24
NC	N25

CG1272/LG1272	
RTAX2000D Function	Pin Number
NC	N26
NC	N31
NC	N32
NC	N33
NC	N4
NC	N7
NC	N8
NC	P25
NC	P8
NC	P9
NC	R1
NC	R10
NC	R27
NC	T1
NC	T7
NC	T8
NC	U12
NC	V12
NC	V26
NC	V29
NC	V4
NC	V8
NC	W11
NC	W25
NC	W26
NC	W29
NC	W33
NC	W36
NC	W6
NC	W7
NC	W8
NC	Y25
NC	Y4
PRA	F18
PRB	A18
PRC	AL19

CG1272/LG1272		CG1272/LG1272		CG1272/LG1272	
RTAX2000D Function	Pin Number	RTAX2000D Function	Pin Number	RTAX2000D Function	Pin Number
PRD	AT19	VCCA	R18	VCCDA	AF19
TCK	H8	VCCA	R20	VCCDA	AN21
TDI	F6	VCCA	R22	VCCDA	AF18
TDO	H9	VCCA	T15	VCCDA	AM32
TMS	F5	VCCA	T17	VCCDA	AK30
TRST	G7	VCCA	T19	VCCDA	AB27
VCCA	M12	VCCA	T21	VCCDA	G31
VCCA	AL5	VCCA	T23	VCCDA	H28
VCCA	AL32	VCCA	U14	VCCDA	C21
VCCA	J30	VCCA	U16	VCCDA	M22
VCCA	AA14	VCCA	U18	VCCDA	D21
VCCA	AA16	VCCA	U20	VCCDA	L19
VCCA	AA18	VCCA	U22	VCCDA	F19
VCCA	AA20	VCCA	V15	VCCDA	D16
VCCA	AA22	VCCA	V17	VCCDA	C16
VCCA	AB15	VCCA	V19	VCCDA	E5
VCCA	AB17	VCCA	V21	VCCIB0	B11
VCCA	AB19	VCCA	V23	VCCIB0	B14
VCCA	AB21	VCCA	W14	VCCIB0	B17
VCCA	AB23	VCCA	W16	VCCIB0	B5
VCCA	AC14	VCCA	W18	VCCIB0	B8
VCCA	AC16	VCCA	W20	VCCIB0	F11
VCCA	AC18	VCCA	W22	VCCIB0	F14
VCCA	AC20	VCCA	Y15	VCCIB0	F17
VCCA	AC22	VCCA	Y17	VCCIB0	F8
VCCA	AP3	VCCA	Y19	VCCIB0	K11
VCCA	AP34	VCCA	Y21	VCCIB0	K14
VCCA	C3	VCCA	Y23	VCCIB0	K17
VCCA	C34	VCCDA	G6	VCCIB0	N15
VCCA	P15	VCCDA	V11	VCCIB0	N17
VCCA	P17	VCCDA	AJ9	VCCIB1	B20
VCCA	P19	VCCDA	AM6	VCCIB1	B23
VCCA	P21	VCCDA	AP16	VCCIB1	B26
VCCA	P23	VCCDA	AM13	VCCIB1	B29
VCCA	R14	VCCDA	AN16	VCCIB1	B32
VCCA	R16	VCCDA	AP21	VCCIB1	F20

CG1272/LG1272	
RTAX2000D Function	Pin Number
VCCIB1	F23
VCCIB1	F26
VCCIB1	F29
VCCIB1	K20
VCCIB1	K23
VCCIB1	K26
VCCIB1	N20
VCCIB1	N22
VCCIB2	E35
VCCIB2	H31
VCCIB2	H35
VCCIB2	K27
VCCIB2	L31
VCCIB2	L35
VCCIB2	P27
VCCIB2	P31
VCCIB2	P35
VCCIB2	R24
VCCIB2	U24
VCCIB2	U27
VCCIB2	U31
VCCIB2	U35
VCCIB3	AB24
VCCIB3	AC27
VCCIB3	AC31
VCCIB3	AC35
VCCIB3	AF31
VCCIB3	AF35
VCCIB3	AG27
VCCIB3	AJ31
VCCIB3	AJ35
VCCIB3	AM35
VCCIB3	Y24
VCCIB3	Y27
VCCIB3	Y31
VCCIB3	Y35

CG1272/LG1272	
RTAX2000D Function	Pin Number
VCCIB4	AD20
VCCIB4	AD22
VCCIB4	AG20
VCCIB4	AG23
VCCIB4	AG26
VCCIB4	AL20
VCCIB4	AL23
VCCIB4	AL26
VCCIB4	AL29
VCCIB4	AR20
VCCIB4	AR23
VCCIB4	AR26
VCCIB4	AR29
VCCIB4	AR32
VCCIB5	AD15
VCCIB5	AD17
VCCIB5	AG11
VCCIB5	AG14
VCCIB5	AG17
VCCIB5	AL11
VCCIB5	AL14
VCCIB5	AL17
VCCIB5	AL8
VCCIB5	AR11
VCCIB5	AR14
VCCIB5	AR17
VCCIB5	AR5
VCCIB5	AR8
VCCIB6	AB13
VCCIB6	AC10
VCCIB6	AC2
VCCIB6	AC6
VCCIB6	AF2
VCCIB6	AF6
VCCIB6	AG10
VCCIB6	AJ2

CG1272/LG1272	
RTAX2000D Function	Pin Number
VCCIB6	AJ6
VCCIB6	AM2
VCCIB6	Y10
VCCIB6	Y13
VCCIB6	Y2
VCCIB6	Y6
VCCIB7	E2
VCCIB7	H2
VCCIB7	H6
VCCIB7	K10
VCCIB7	L2
VCCIB7	L6
VCCIB7	P10
VCCIB7	P2
VCCIB7	P6
VCCIB7	R13
VCCIB7	U10
VCCIB7	U13
VCCIB7	U2
VCCIB7	U6
VPUMP	F32

CG1272/LG1272		CG1272/LG1272		CG1272/LG1272	
RTAX4000D Function	Pin Number	RTAX4000D Function	Pin Number	RTAX4000D Function	Pin Number
Bank 0		IO17PB0F1	E11	IO35PB0F3	D15
IO00NB0F0	E9	IO18NB0F1	K13	IO36NB0F3	J16
IO00PB0F0	D9	IO18PB0F1	K12	IO36PB0F3	J15
IO01NB0F0	D8	IO19NB0F1	B4	IO37NB0F3	A11
IO01PB0F0	D7	IO19PB0F1	C4	IO37PB0F3	A10
IO02NB0F0	J10	IO20NB0F1	H13	IO38NB0F3	H15
IO02PB0F0	J9	IO20PB0F1	H12	IO38PB0F3	H14
IO03NB0F0	E7	IO21NB0F2	C13	IO39NB0F3	B16
IO03PB0F0	E8	IO21PB0F2	C12	IO39PB0F3	B15
IO04NB0F0	F9	IO22NB0F2	M14	IO40NB0F3	M16
IO04PB0F0	G9	IO22PB0F2	M13	IO40PB0F3	M17
IO05NB0F0	B7	IO23NB0F2	B10	IO41NB0F3	E16
IO05PB0F0	B6	IO23PB0F2	B9	IO41PB0F3	F16
IO06NB0F0	L13	IO24NB0F2	J14	IO42NB0F4	H17
IO06PB0F0	L12	IO24PB0F2	J13	IO42PB0F4	J17
IO07NB0F0	C7	IO25NB0F2	A8	IO43NB0F4	A14
IO07PB0F0	C6	IO25PB0F2	A9	IO43PB0F4	A15
IO08NB0F0	F10	IO26NB0F2	G13	IO44NB0F4	G16
IO08PB0F0	G10	IO26PB0F2	F13	IO44PB0F4	H16
IO09NB0F0	D10	IO27NB0F2	D14	IO45NB0F4	A17
IO09PB0F0	E10	IO27PB0F2	D13	IO45PB0F4	A16
IO10NB0F0	H11	IO28NB0F2	L16	IO46NB0F4	M18
IO10PB0F0	H10	IO28PB0F2	L15	IO46PB0F4	M19
IO11NB0F0	A5	IO29NB0F2	B13	IO47NB0F4	E18
IO11PB0F0	A4	IO29PB0F2	B12	IO47PB0F4	E17
IO12NB0F1	D6	IO30NB0F2	C10	IO48NB0F4	G18
IO12PB0F1	D5	IO30PB0F2	C9	IO48PB0F4	H18
IO13NB0F1	A7	IO31NB0F2	E15	IO49NB0F4	C18
IO13PB0F1	A6	IO31PB0F2	E14	IO49PB0F4	B18
IO14NB0F1	J12	IO32NB0F2	K15	IO50NB0F4/HCLKAN	J18
IO14PB0F1	J11	IO32PB0F2	K16	IO50PB0F4/HCLKAP	K18
IO15NB0F1	D12	IO33NB0F3	A13	IO51NB0F4/HCLKBN	D18
IO15PB0F1	D11	IO33PB0F3	A12	IO51PB0F4/HCLKBP	D17
IO16NB0F1	F12	IO34NB0F3	G15	Bank 1	
IO16PB0F1	G12	IO34PB0F3	F15	IO52NB1F6/HCLKCN	K19
IO17NB0F1	E12	IO35NB0F3	C15	IO52PB1F6/HCLKCP	J19

CG1272/LG1272	
RTAX4000D Function	Pin Number
IO53NB1F6/HCLKDN	D20
IO53PB1F6/HCLKDP	D19
IO54NB1F6	H19
IO54PB1F6	G19
IO55NB1F6	B19
IO55PB1F6	C19
IO56NB1F6	M20
IO56PB1F6	M21
IO57NB1F6	E20
IO57PB1F6	E19
IO58NB1F6	H21
IO58PB1F6	G21
IO59NB1F6	A21
IO59PB1F6	A20
IO60NB1F7	H20
IO60PB1F7	J20
IO61NB1F7	A22
IO61PB1F7	A23
IO62NB1F7	D32
IO62PB1F7	D31
IO63NB1F7	F21
IO63PB1F7	E21
IO64NB1F7	J22
IO64PB1F7	J21
IO65NB1F7	B22
IO65PB1F7	B21
IO66NB1F7	H23
IO66PB1F7	H22
IO67NB1F7	D22
IO67PB1F7	C22
IO68NB1F7	K22
IO68PB1F7	K21
IO69NB1F7	A27
IO69PB1F7	A26
IO70NB1F7	F22
IO70PB1F7	G22

CG1272/LG1272	
RTAX4000D Function	Pin Number
IO71NB1F7	E23
IO71PB1F7	E22
IO72NB1F8	L22
IO72PB1F8	L21
IO73NB1F8	A25
IO73PB1F8	A24
IO74NB1F8	C28
IO74PB1F8	C27
IO75NB1F8	D24
IO75PB1F8	D23
IO76NB1F8	J24
IO76PB1F8	J23
IO77NB1F8	B25
IO77PB1F8	B24
IO78NB1F8	F24
IO78PB1F8	G24
IO79NB1F8	A28
IO79PB1F8	A29
IO80NB1F8	M24
IO80PB1F8	M23
IO81NB1F8	B28
IO81PB1F8	B27
IO82NB1F9	H25
IO82PB1F9	H24
IO83NB1F9	C25
IO83PB1F9	C24
IO84NB1F9	K25
IO84PB1F9	K24
IO85NB1F9	A33
IO85PB1F9	A32
IO86NB1F9	G25
IO86PB1F9	F25
IO87NB1F9	E26
IO87PB1F9	E25
IO88NB1F9	J26
IO88PB1F9	J25

CG1272/LG1272	
RTAX4000D Function	Pin Number
IO89NB1F9	D26
IO89PB1F9	D25
IO90NB1F9	E31
IO90PB1F9	E32
IO91NB1F9	A31
IO91PB1F9	A30
IO92NB1F9	H27
IO92PB1F9	H26
IO93NB1F9	C33
IO93PB1F9	B33
IO94NB1F10	G27
IO94PB1F10	F27
IO95NB1F10	E27
IO95PB1F10	D27
IO96NB1F10	L24
IO96PB1F10	L25
IO97NB1F10	C31
IO97PB1F10	C30
IO98NB1F10	F28
IO98PB1F10	G28
IO99NB1F10	B31
IO99PB1F10	B30
IO100NB1F10	J28
IO100PB1F10	J27
IO101NB1F10	E29
IO101PB1F10	E30
IO102NB1F10	D28
IO102PB1F10	E28
IO103NB1F10	D30
IO103PB1F10	D29
Bank 2	
IO104NB2F12	L29
IO104PB2F12	L28
IO105NB2F12	D35
IO105PB2F12	D34
IO106NB2F12	H33

CG1272/LG1272		CG1272/LG1272		CG1272/LG1272	
RTAX4000D Function	Pin Number	RTAX4000D Function	Pin Number	RTAX4000D Function	Pin Number
IO106PB2F12	J33	IO124PB2F14	J35	IO142PB2F16	R34
IO107NB2F12	F34	IO125NB2F14	P25	IO143NB2F16	T32
IO107PB2F12	F33	IO125PB2F14	N25	IO143PB2F16	T31
IO108NB2F12	G33	IO126NB2F14	H36	IO144NB2F16	T35
IO108PB2F12	G32	IO126PB2F14	G36	IO144PB2F16	T34
IO109NB2F12	M28	IO127NB2F14	N32	IO145NB2F16	T30
IO109PB2F12	M27	IO127PB2F14	N31	IO145PB2F16	T29
IO110NB2F12	K33	IO128NB2F14	N34	IO146NB2F16	R33
IO110PB2F12	K32	IO128PB2F14	M34	IO146PB2F16	R32
IO111NB2F12	K31	IO129NB2F14	P29	IO147NB2F16	V25
IO111PB2F12	K30	IO129PB2F14	P28	IO147PB2F16	U25
IO112NB2F13	K34	IO130NB2F15	N33	IO148NB2F17	T36
IO112PB2F13	J34	IO130PB2F15	M33	IO148PB2F17	R36
IO113NB2F13	N26	IO131NB2F15	R26	IO149NB2F17	U29
IO113PB2F13	M26	IO131PB2F15	R25	IO149PB2F17	U28
IO114NB2F13	K28	IO132NB2F15	K36	IO150NB2F17	U33
IO114PB2F13	K29	IO132PB2F15	J36	IO150PB2F17	T33
IO115NB2F13	H32	IO133NB2F15	R29	IO151NB2F17	W25
IO115PB2F13	J32	IO133PB2F15	R28	IO151PB2F17	Y25
IO116NB2F13	G35	IO134NB2F15	N35	IO152NB2F17	V36
IO116PB2F13	G34	IO134PB2F15	M35	IO152PB2F17	U36
IO117NB2F13	M29	IO135NB2F15	F35	IO153NB2F17	V31
IO117PB2F13	M30	IO135PB2F15	F36	IO153PB2F17	V30
IO118NB2F13	E33	IO136NB2F15	M36	IO154NB2F17	V32
IO118PB2F13	D33	IO136PB2F15	L36	IO154PB2F17	U32
IO119NB2F13	M32	IO137NB2F15	T26	IO155NB2F17	V27
IO119PB2F13	M31	IO137PB2F15	T25	IO155PB2F17	V28
IO120NB2F13	E36	IO138NB2F15	P33	IO156NB2F17	W34
IO120PB2F13	D36	IO138PB2F15	P32	IO156PB2F17	V34
IO121NB2F14	N28	IO139NB2F16	R31	Bank 3	
IO121PB2F14	N27	IO139PB2F16	R30	IO157NB3F18	W29
IO122NB2F14	L33	IO140NB2F16	P36	IO157PB3F18	V29
IO122PB2F14	L32	IO140PB2F16	N36	IO158NB3F18	W35
IO123NB2F14	N30	IO141NB2F16	T28	IO158PB3F18	V35
IO123PB2F14	N29	IO141PB2F16	T27	IO159NB3F18	W30
IO124NB2F14	K35	IO142NB2F16	R35	IO159PB3F18	W31

CG1272/LG1272	
RTAX4000D Function	Pin Number
IO160NB3F18	AA36
IO160PB3F18	Y36
IO161NB3F18	W27
IO161PB3F18	W28
IO162NB3F18	Y32
IO162PB3F18	W32
IO163NB3F18	Y28
IO163PB3F18	Y29
IO164NB3F18	AC36
IO164PB3F18	AB36
IO165NB3F18	AA26
IO165PB3F18	AA25
IO166NB3F19	AA33
IO166PB3F19	Y33
IO167NB3F19	AA32
IO167PB3F19	AA31
IO168NB3F19	AA34
IO168PB3F19	AA35
IO169NB3F19	AA29
IO169PB3F19	AA30
IO170NB3F19	AB32
IO170PB3F19	AB33
IO171NB3F19	AB31
IO171PB3F19	AB30
IO172NB3F19	AE36
IO172PB3F19	AD36
IO173NB3F19	AA27
IO173PB3F19	AA28
IO174NB3F19	AB34
IO174PB3F19	AB35
IO175NB3F20	AL35
IO175PB3F20	AL36
IO176NB3F20	AG36
IO176PB3F20	AF36
IO177NB3F20	AB25
IO177PB3F20	AB26

CG1272/LG1272	
RTAX4000D Function	Pin Number
IO178NB3F20	AC32
IO178PB3F20	AC33
IO179NB3F20	AB29
IO179PB3F20	AB28
IO180NB3F20	AJ36
IO180PB3F20	AH36
IO181NB3F20	AC25
IO181PB3F20	AD25
IO182NB3F20	AE35
IO182PB3F20	AD35
IO183NB3F20	AC29
IO183PB3F20	AC28
IO184NB3F21	AE34
IO184PB3F21	AD34
IO185NB3F21	AE26
IO185PB3F21	AD26
IO186NB3F21	AE33
IO186PB3F21	AD33
IO187NB3F21	AD30
IO187PB3F21	AD29
IO188NB3F21	AH35
IO188PB3F21	AG35
IO189NB3F21	AD32
IO189PB3F21	AD31
IO190NB3F21	AK35
IO190PB3F21	AK36
IO191NB3F21	AE32
IO191PB3F21	AE31
IO192NB3F21	AN36
IO192PB3F21	AM36
IO193NB3F22	AD27
IO193PB3F22	AD28
IO194NB3F22	AF32
IO194PB3F22	AF33
IO195NB3F22	AE30
IO195PB3F22	AE29

CG1272/LG1272	
RTAX4000D Function	Pin Number
IO196NB3F22	AK34
IO196PB3F22	AL34
IO197NB3F22	AE28
IO197PB3F22	AE27
IO198NB3F22	AN33
IO198PB3F22	AM33
IO199NB3F22	AH31
IO199PB3F22	AH30
IO200NB3F22	AH34
IO200PB3F22	AG34
IO201NB3F22	AF29
IO201PB3F22	AF28
IO202NB3F23	AG32
IO202PB3F23	AG33
IO203NB3F23	AG31
IO203PB3F23	AG30
IO204NB3F23	AL33
IO204PB3F23	AK33
IO205NB3F23	AK32
IO205PB3F23	AK31
IO206NB3F23	AH33
IO206PB3F23	AJ33
IO207NB3F23	AN34
IO207PB3F23	AN35
IO208NB3F23	AG29
IO208PB3F23	AG28
IO209NB3F23	AJ32
IO209PB3F23	AH32
Bank 4	
IO210NB4F24	AM28
IO210PB4F24	AN28
IO211NB4F24	AN29
IO211PB4F24	AN30
IO212NB4F24	AH27
IO212PB4F24	AH28
IO213NB4F24	AM30

CG1272/LG1272		CG1272/LG1272		CG1272/LG1272	
RTAX4000D Function	Pin Number	RTAX4000D Function	Pin Number	RTAX4000D Function	Pin Number
IO213PB4F24	AM29	IO231PB4F25	AT27	IO249PB4F27	AR22
IO214NB4F24	AL28	IO232NB4F26	AE23	IO250NB4F27	AE21
IO214PB4F24	AK28	IO232PB4F26	AE24	IO250PB4F27	AE20
IO215NB4F24	AR30	IO233NB4F26	AR27	IO251NB4F27	AM21
IO215PB4F24	AR31	IO233PB4F26	AR28	IO251PB4F27	AL21
IO216NB4F24	AF24	IO234NB4F26	AH23	IO252NB4F27	AH20
IO216PB4F24	AF25	IO234PB4F26	AH24	IO252PB4F27	AJ20
IO217NB4F24	AP30	IO235NB4F26	AT29	IO253NB4F27	AT23
IO217PB4F24	AP31	IO235PB4F26	AT28	IO253PB4F27	AT22
IO218NB4F24	AL27	IO236NB4F26	AK24	IO254NB4F28	AK21
IO218PB4F24	AK27	IO236PB4F26	AL24	IO254PB4F28	AJ21
IO219NB4F24	AN27	IO237NB4F26	AR24	IO255NB4F28	AT20
IO219PB4F24	AM27	IO237PB4F26	AR25	IO255PB4F28	AT21
IO220NB4F25	AJ26	IO238NB4F26	AF21	IO256NB4F28	AE18
IO220PB4F25	AJ27	IO238PB4F26	AF22	IO256PB4F28	AE19
IO221NB4F25	AT32	IO239NB4F26	AP24	IO257NB4F28	AM19
IO221PB4F25	AT33	IO239PB4F26	AP25	IO257PB4F28	AM20
IO222NB4F25	AN31	IO240NB4F26	AP27	IO258NB4F28	AK19
IO222PB4F25	AN32	IO240PB4F26	AP28	IO258PB4F28	AJ19
IO223NB4F25	AT30	IO241NB4F26	AN23	IO259NB4F28	AP19
IO223PB4F25	AT31	IO241PB4F26	AN24	IO259PB4F28	AR19
IO224NB4F25	AH25	IO242NB4F27	AG21	IO260NB4F28/CLKEN	AH19
IO224PB4F25	AH26	IO242PB4F27	AG22	IO260PB4F28/CLKEP	AG19
IO225NB4F25	AN25	IO243NB4F27	AM22	IO261NB4F28/CLKFN	AN19
IO225PB4F25	AN26	IO243PB4F27	AM23	IO261PB4F28/CLKFP	AN20
IO226NB4F25	AL25	IO244NB4F27	AK22	Bank 5	
IO226PB4F25	AK25	IO244PB4F27	AL22	IO262NB5F30/CLKGN	AG18
IO227NB4F25	AM25	IO245NB4F27	AT24	IO262PB5F30/CLKGP	AH18
IO227PB4F25	AM26	IO245PB4F27	AT25	IO263NB5F30/CLKHN	AN17
IO228NB4F25	AG25	IO246NB4F27	AH21	IO263PB5F30/CLKHP	AN18
IO228PB4F25	AG24	IO246PB4F27	AH22	IO264NB5F30	AJ18
IO229NB4F25	AR33	IO247NB4F27	AP22	IO264PB5F30	AK18
IO229PB4F25	AP33	IO247PB4F27	AN22	IO265NB5F30	AR18
IO230NB4F25	AJ24	IO248NB4F27	AJ22	IO265PB5F30	AP18
IO230PB4F25	AJ25	IO248PB4F27	AJ23	IO266NB5F30	AE17
IO231NB4F25	AT26	IO249NB4F27	AR21	IO266PB5F30	AE16

CG1272/LG1272	
RTAX4000D Function	Pin Number
IO267NB5F30	AM17
IO267PB5F30	AM18
IO268NB5F30	AJ16
IO268PB5F30	AK16
IO269NB5F30	AT16
IO269PB5F30	AT17
IO270NB5F30	AF16
IO270PB5F30	AF15
IO271NB5F30	AT15
IO271PB5F30	AT14
IO272NB5F31	AH17
IO272PB5F31	AJ17
IO273NB5F31	AL16
IO273PB5F31	AM16
IO274NB5F31	AH15
IO274PB5F31	AH16
IO275NB5F31	AR15
IO275PB5F31	AR16
IO276NB5F31	AJ14
IO276PB5F31	AJ15
IO277NB5F31	AN15
IO277PB5F31	AP15
IO278NB5F31	AG15
IO278PB5F31	AG16
IO279NB5F31	AT10
IO279PB5F31	AT11
IO280NB5F31	AL15
IO280PB5F31	AK15
IO281NB5F32	AM14
IO281PB5F32	AM15
IO282NB5F32	AE13
IO282PB5F32	AE14
IO283NB5F32	AT12
IO283PB5F32	AT13
IO284NB5F32	AP9
IO284PB5F32	AP10

CG1272/LG1272	
RTAX4000D Function	Pin Number
IO285NB5F32	AN13
IO285PB5F32	AN14
IO286NB5F32	AN9
IO286PB5F32	AM9
IO287NB5F32	AR12
IO287PB5F32	AR13
IO288NB5F32	AL13
IO288PB5F32	AK13
IO289NB5F32	AT9
IO289PB5F32	AT8
IO290NB5F32	AH13
IO290PB5F32	AH14
IO291NB5F32	AR9
IO291PB5F32	AR10
IO292NB5F32	AJ12
IO292PB5F32	AJ13
IO293NB5F33	AP12
IO293PB5F33	AP13
IO294NB5F33	AG13
IO294PB5F33	AF13
IO295NB5F33	AP4
IO295PB5F33	AR4
IO296NB5F33	AG12
IO296PB5F33	AF12
IO297NB5F33	AM11
IO297PB5F33	AM12
IO298NB5F33	AK12
IO298PB5F33	AL12
IO299NB5F33	AN11
IO299PB5F33	AN12
IO300NB5F33	AN5
IO300PB5F33	AN6
IO301NB5F33	AT6
IO301PB5F33	AT7
IO302NB5F34	AH11
IO302PB5F34	AH12

CG1272/LG1272	
RTAX4000D Function	Pin Number
IO303NB5F34	AT4
IO303PB5F34	AT5
IO304NB5F34	AJ10
IO304PB5F34	AJ11
IO305NB5F34	AM10
IO305PB5F34	AN10
IO306NB5F34	AK10
IO306PB5F34	AL10
IO307NB5F34	AP6
IO307PB5F34	AP7
IO308NB5F34	AK9
IO308PB5F34	AL9
IO309NB5F34	AR6
IO309PB5F34	AR7
IO310NB5F34	AH9
IO310PB5F34	AH10
IO311NB5F34	AM8
IO311PB5F34	AM7
IO312NB5F34	AG9
IO312PB5F34	AG8
IO313NB5F34	AN7
IO313PB5F34	AN8
Bank 6	
IO314NB6F36	AF8
IO314PB6F36	AF9
IO315NB6F36	AN2
IO315PB6F36	AN3
IO316NB6F36	AH4
IO316PB6F36	AJ4
IO317NB6F36	AL3
IO317PB6F36	AL4
IO318NB6F36	AK4
IO318PB6F36	AK5
IO319NB6F36	AE10
IO319PB6F36	AE9
IO320NB6F36	AG4

CG1272/LG1272		CG1272/LG1272		CG1272/LG1272	
RTAX4000D Function	Pin Number	RTAX4000D Function	Pin Number	RTAX4000D Function	Pin Number
IO320PB6F36	AG5	IO338PB6F38	AE3	IO356PB6F40	AB5
IO321NB6F36	AE11	IO339NB6F38	AD5	IO357NB6F40	W12
IO321PB6F36	AD11	IO339PB6F38	AD6	IO357PB6F40	Y12
IO322NB6F37	AG3	IO340NB6F39	AD4	IO358NB6F41	AA1
IO322PB6F37	AH3	IO340PB6F39	AE4	IO358PB6F41	AB1
IO323NB6F37	AG7	IO341NB6F39	AB8	IO359NB6F41	Y8
IO323PB6F37	AG6	IO341PB6F39	AB9	IO359PB6F41	Y9
IO324NB6F37	AH7	IO342NB6F39	AG1	IO360NB6F41	Y4
IO324PB6F37	AH6	IO342PB6F39	AH1	IO360PB6F41	AA4
IO325NB6F37	AJ5	IO343NB6F39	AA12	IO361NB6F41	U12
IO325PB6F37	AH5	IO343PB6F39	AB12	IO361PB6F41	V12
IO326NB6F37	AK2	IO344NB6F39	AD2	IO362NB6F41	W1
IO326PB6F37	AK3	IO344PB6F39	AE2	IO362PB6F41	Y1
IO327NB6F37	AE7	IO345NB6F39	AA11	IO363NB6F41	W6
IO327PB6F37	AE8	IO345PB6F39	AB11	IO363PB6F41	W7
IO328NB6F37	AM4	IO346NB6F39	AE1	IO364NB6F41	W5
IO328PB6F37	AN4	IO346PB6F39	AF1	IO364PB6F41	Y5
IO329NB6F37	AD9	IO347NB6F39	AL1	IO365NB6F41	W10
IO329PB6F37	AD10	IO347PB6F39	AL2	IO365PB6F41	W9
IO330NB6F37	AM1	IO348NB6F39	AC4	IO366NB6F41	V2
IO330PB6F37	AN1	IO348PB6F39	AC5	IO366PB6F41	W2
IO331NB6F38	AE5	IO349NB6F40	AB6	Bank 7	
IO331PB6F38	AE6	IO349PB6F40	AB7	IO367NB7F42	V8
IO332NB6F38	AF4	IO350NB6F40	AC1	IO367PB7F42	W8
IO332PB6F38	AF5	IO350PB6F40	AD1	IO368NB7F42	V3
IO333NB6F38	AD8	IO351NB6F40	AA9	IO368PB7F42	W3
IO333PB6F38	AD7	IO351PB6F40	AA10	IO369NB7F42	V9
IO334NB6F38	AG2	IO352NB6F40	AB2	IO369PB7F42	V10
IO334PB6F38	AH2	IO352PB6F40	AB3	IO370NB7F42	U1
IO335NB6F38	AC12	IO353NB6F40	AA7	IO370PB7F42	V1
IO335PB6F38	AD12	IO353PB6F40	AA8	IO371NB7F42	V7
IO336NB6F38	AJ1	IO354NB6F40	AA2	IO371PB7F42	V6
IO336PB6F38	AK1	IO354PB6F40	AA3	IO372NB7F42	U5
IO337NB6F38	AC8	IO355NB6F40	AA5	IO372PB7F42	V5
IO337PB6F38	AC9	IO355PB6F40	AA6	IO373NB7F42	U9
IO338NB6F38	AD3	IO356NB6F40	AB4	IO373PB7F42	U8

CG1272/LG1272	
RTAX4000D Function	Pin Number
IO374NB7F42	R1
IO374PB7F42	T1
IO375NB7F42	T11
IO375PB7F42	T12
IO376NB7F43	T4
IO376PB7F43	U4
IO377NB7F43	T8
IO377PB7F43	T7
IO378NB7F43	T3
IO378PB7F43	T2
IO379NB7F43	T5
IO379PB7F43	T6
IO380NB7F43	R5
IO380PB7F43	R4
IO381NB7F43	R6
IO381PB7F43	R7
IO382NB7F43	N1
IO382PB7F43	P1
IO383NB7F43	T10
IO383PB7F43	T9
IO384NB7F43	R3
IO384PB7F43	R2
IO385NB7F44	R12
IO385PB7F44	R11
IO386NB7F44	L1
IO386PB7F44	M1
IO387NB7F44	G2
IO387PB7F44	F2
IO388NB7F44	P5
IO388PB7F44	P4
IO389NB7F44	R8
IO389PB7F44	R9
IO390NB7F44	J1
IO390PB7F44	K1
IO391NB7F44	N12
IO391PB7F44	P12

CG1272/LG1272	
RTAX4000D Function	Pin Number
IO392NB7F44	M2
IO392PB7F44	N2
IO393NB7F44	P9
IO393PB7F44	P8
IO394NB7F45	M3
IO394PB7F45	N3
IO395NB7F45	M11
IO395PB7F45	N11
IO396NB7F45	M4
IO396PB7F45	N4
IO397NB7F45	N5
IO397PB7F45	N6
IO398NB7F45	J2
IO398PB7F45	K2
IO399NB7F45	N8
IO399PB7F45	N7
IO400NB7F45	G1
IO400PB7F45	H1
IO401NB7F45	M5
IO401PB7F45	M6
IO402NB7F45	E1
IO402PB7F45	F1
IO403NB7F46	N10
IO403PB7F46	N9
IO404NB7F46	L5
IO404PB7F46	L4
IO405NB7F46	M7
IO405PB7F46	M8
IO406NB7F46	G3
IO406PB7F46	F3
IO407NB7F46	M10
IO407PB7F46	M9
IO408NB7F46	D4
IO408PB7F46	D3
IO409NB7F46	J7
IO409PB7F46	J6

CG1272/LG1272	
RTAX4000D Function	Pin Number
IO410NB7F46	J3
IO410PB7F46	K3
IO411NB7F46	L8
IO411PB7F46	L9
IO412NB7F47	K5
IO412PB7F47	K4
IO413NB7F47	K7
IO413PB7F47	K6
IO414NB7F47	E4
IO414PB7F47	F4
IO415NB7F47	G4
IO415PB7F47	G5
IO416NB7F47	H4
IO416PB7F47	J4
IO417NB7F47	D2
IO417PB7F47	D1
IO418NB7F47	K8
IO418PB7F47	K9
IO419NB7F47	H5
IO419PB7F47	J5
Dedicated I/O	
GND	AA13
GND	AA15
GND	AA17
GND	AA19
GND	AA21
GND	AA23
GND	AA24
GND	AB14
GND	AB16
GND	AB18
GND	AB20
GND	AB22
GND	AC3
GND	AC7
GND	AC11

CG1272/LG1272		CG1272/LG1272		CG1272/LG1272	
RTAX4000D Function	Pin Number	RTAX4000D Function	Pin Number	RTAX4000D Function	Pin Number
GND	AC13	GND	AJ34	GND	C17
GND	AC15	GND	AK6	GND	C20
GND	AC17	GND	AK8	GND	C23
GND	AC19	GND	AK11	GND	C26
GND	AC21	GND	AK14	GND	C29
GND	AC23	GND	AK17	GND	C32
GND	AC24	GND	AK20	GND	C35
GND	AC26	GND	AK23	GND	E3
GND	AC30	GND	AK26	GND	E34
GND	AC34	GND	AK29	GND	F7
GND	AD13	GND	AL7	GND	F30
GND	AD14	GND	AL18	GND	G8
GND	AD16	GND	AL31	GND	G11
GND	AD18	GND	AM3	GND	G14
GND	AD19	GND	AM34	GND	G17
GND	AD21	GND	AP2	GND	G20
GND	AD23	GND	AP5	GND	G23
GND	AD24	GND	AP8	GND	G26
GND	AE15	GND	AP11	GND	G29
GND	AE25	GND	AP14	GND	H3
GND	AF3	GND	AP17	GND	H7
GND	AF7	GND	AP20	GND	H30
GND	AF10	GND	AP23	GND	H34
GND	AF11	GND	AP26	GND	J8
GND	AF14	GND	AP29	GND	J31
GND	AF17	GND	AP32	GND	L3
GND	AF20	GND	AP35	GND	L7
GND	AF23	GND	AR3	GND	L10
GND	AF26	GND	AR34	GND	L11
GND	AF27	GND	B3	GND	L14
GND	AF30	GND	B34	GND	L17
GND	AF34	GND	C2	GND	L20
GND	AJ3	GND	C5	GND	L23
GND	AJ7	GND	C8	GND	L26
GND	AJ29	GND	C11	GND	L27
GND	AJ30	GND	C14	GND	L30

CG1272/LG1272	
RTAX4000D Function	Pin Number
GND	L34
GND	M15
GND	M25
GND	N14
GND	N16
GND	N18
GND	N19
GND	N21
GND	N23
GND	N24
GND	P3
GND	P7
GND	P11
GND	P13
GND	P14
GND	P16
GND	P18
GND	P20
GND	P22
GND	P24
GND	P26
GND	P30
GND	P34
GND	R15
GND	R17
GND	R19
GND	R21
GND	R23
GND	R27
GND	T13
GND	T14
GND	T16
GND	T18
GND	T20
GND	T22
GND	T24

CG1272/LG1272	
RTAX4000D Function	Pin Number
GND	U3
GND	U7
GND	U11
GND	U15
GND	U17
GND	U19
GND	U21
GND	U23
GND	U26
GND	U30
GND	U34
GND	V4
GND	V13
GND	V14
GND	V16
GND	V18
GND	V20
GND	V22
GND	V24
GND	V33
GND	W4
GND	W11
GND	W13
GND	W15
GND	W17
GND	W19
GND	W21
GND	W23
GND	W24
GND	W26
GND	Y3
GND	Y7
GND	Y11
GND	Y14
GND	Y16
GND	Y18

CG1272/LG1272	
RTAX4000D Function	Pin Number
GND	Y20
GND	Y22
GND	Y26
GND	Y30
GND	Y34
NC	AJ8
NC	W36
PRA	F18
PRB	A18
PRC	AL19
PRD	AT19
TCK	H8
TDI	F6
TDO	H9
TMS	F5
TRST	G7
VCCA	M12
VCCA	AE12
VCCA	AL5
VCCA	AT18
VCCA	AL32
VCCA	W33
VCCA	J30
VCCA	A19
VCCA	AA14
VCCA	AA16
VCCA	AA18
VCCA	AA20
VCCA	AA22
VCCA	AB15
VCCA	AB17
VCCA	AB19
VCCA	AB21
VCCA	AB23
VCCA	AC14
VCCA	AC16

CG1272/LG1272		CG1272/LG1272		CG1272/LG1272	
RTAX4000D Function	Pin Number	RTAX4000D Function	Pin Number	RTAX4000D Function	Pin Number
VCCA	AC18	VCCA	W22	VCCDA	G30
VCCA	AC20	VCCA	Y15	VCCDA	J29
VCCA	AC22	VCCA	Y17	VCCDA	G31
VCCA	AP3	VCCA	Y19	VCCDA	C21
VCCA	AP34	VCCA	Y21	VCCDA	F31
VCCA	C3	VCCA	Y23	VCCDA	D21
VCCA	C34	VCCDA	G6	VCCDA	M22
VCCA	P15	VCCDA	R10	VCCDA	F19
VCCA	P17	VCCDA	V11	VCCDA	D16
VCCA	P19	VCCDA	AB10	VCCDA	L19
VCCA	P21	VCCDA	AK7	VCCDA	C16
VCCA	P23	VCCDA	AL6	VCCDA	L18
VCCA	R14	VCCDA	AM13	VCCDA	N13
VCCA	R16	VCCDA	AH8	VCCDA	E6
VCCA	R18	VCCDA	AM5	VCCDA	E13
VCCA	R20	VCCDA	AJ9	VCCDA	E5
VCCA	R22	VCCDA	AP16	VCCIB0	B11
VCCA	T15	VCCDA	AM6	VCCIB0	B14
VCCA	T17	VCCDA	AN16	VCCIB0	B17
VCCA	T19	VCCDA	AF18	VCCIB0	B5
VCCA	T21	VCCDA	AF19	VCCIB0	B8
VCCA	T23	VCCDA	AN21	VCCIB0	F11
VCCA	U14	VCCDA	AE22	VCCIB0	F14
VCCA	U16	VCCDA	AP21	VCCIB0	F17
VCCA	U18	VCCDA	AM31	VCCIB0	F8
VCCA	U20	VCCDA	AJ28	VCCIB0	K11
VCCA	U22	VCCDA	AM32	VCCIB0	K14
VCCA	V15	VCCDA	AM24	VCCIB0	K17
VCCA	V17	VCCDA	AL30	VCCIB0	N15
VCCA	V19	VCCDA	AK30	VCCIB0	N17
VCCA	V21	VCCDA	AH29	VCCIB1	B20
VCCA	V23	VCCDA	V26	VCCIB1	B23
VCCA	W14	VCCDA	AB27	VCCIB1	B26
VCCA	W16	VCCDA	H29	VCCIB1	B29
VCCA	W18	VCCDA	H28	VCCIB1	B32
VCCA	W20	VCCDA	E24	VCCIB1	F20

CG1272/LG1272	
RTAX4000D Function	Pin Number
VCCIB1	F23
VCCIB1	F26
VCCIB1	F29
VCCIB1	K20
VCCIB1	K23
VCCIB1	K26
VCCIB1	N20
VCCIB1	N22
VCCIB2	E35
VCCIB2	H31
VCCIB2	H35
VCCIB2	K27
VCCIB2	L31
VCCIB2	L35
VCCIB2	P27
VCCIB2	P31
VCCIB2	P35
VCCIB2	R24
VCCIB2	U24
VCCIB2	U27
VCCIB2	U31
VCCIB2	U35
VCCIB3	AB24
VCCIB3	AC27
VCCIB3	AC31
VCCIB3	AC35
VCCIB3	AF31
VCCIB3	AF35
VCCIB3	AG27
VCCIB3	AJ31
VCCIB3	AJ35
VCCIB3	AM35
VCCIB3	Y24
VCCIB3	Y27
VCCIB3	Y31
VCCIB3	Y35

CG1272/LG1272	
RTAX4000D Function	Pin Number
VCCIB4	AD20
VCCIB4	AD22
VCCIB4	AG20
VCCIB4	AG23
VCCIB4	AG26
VCCIB4	AL20
VCCIB4	AL23
VCCIB4	AL26
VCCIB4	AL29
VCCIB4	AR20
VCCIB4	AR23
VCCIB4	AR26
VCCIB4	AR29
VCCIB4	AR32
VCCIB5	AD15
VCCIB5	AD17
VCCIB5	AG11
VCCIB5	AG14
VCCIB5	AG17
VCCIB5	AL11
VCCIB5	AL14
VCCIB5	AL17
VCCIB5	AL8
VCCIB5	AR11
VCCIB5	AR14
VCCIB5	AR17
VCCIB5	AR5
VCCIB5	AR8
VCCIB6	AB13
VCCIB6	AC10
VCCIB6	AC2
VCCIB6	AC6
VCCIB6	AF2
VCCIB6	AF6
VCCIB6	AG10
VCCIB6	AJ2

CG1272/LG1272	
RTAX4000D Function	Pin Number
VCCIB6	AJ6
VCCIB6	AM2
VCCIB6	Y10
VCCIB6	Y13
VCCIB6	Y2
VCCIB6	Y6
VCCIB7	E2
VCCIB7	H2
VCCIB7	H6
VCCIB7	K10
VCCIB7	L2
VCCIB7	L6
VCCIB7	P10
VCCIB7	P2
VCCIB7	P6
VCCIB7	R13
VCCIB7	U10
VCCIB7	U13
VCCIB7	U2
VCCIB7	U6
VPUMP	F32

4 – Related Documents

Application Notes

Simultaneous Switching Noise and Signal Integrity

http://www.microsemi.com/soc/documents/SSN_AN.pdf

Differences Between RTAX-S/SL and Axcelerator

http://www.microsemi.com/soc/documents/RTAXS_AX_Features_AN.pdf

Using EDAC RAM for RadTolerant RTAX-S/SL FPGAs and Axcelerator FPGAs

http://www.microsemi.com/soc/documents/EDAC_AN.pdf

Prototyping for RTAX-S and RTAX-SL Devices

http://www.microsemi.com/soc/documents/PrototypingRTAXS_AN.pdf

Implementation of Security in Actel Antifuse FPGAs

http://www.microsemi.com/soc/documents/Antifuse_Security_AN.pdf

Actel CQFP to FBGA Adapter Socket Instructions

http://www.microsemi.com/soc/documents/CCGA_FBGA_AN.pdf

Actel CCGA to FBGA Adapter Socket Instructions

http://www.microsemi.com/soc/documents/CQ352-FPGA_Adapter_AN.pdf

IEEE Standard 1149.1 (JTAG) in the Axcelerator Family

http://www.microsemi.com/soc/documents/AX_JTAG_AN.pdf

User's Guides and Manuals

Antifuse Macro Library Guide

http://www.microsemi.com/soc/documents/libguide_UG.pdf

SmartGen, FlashROM, Analog System Builder, and Flash Memory System Builder User's Guide

http://www.microsemi.com/soc/documents/smarttime_ug.pdf

Silicon Sculptor User's Guide

http://www.microsemi.com/soc/documents/SiliSculptII_Sculpt3_ug.pdf

Silicon Explorer II User's Guide

http://www.microsemi.com/soc/documents/Silexpl_UG.pdf

White Papers

Design Security in Nonvolatile Flash and Antifuse FPGAs

http://www.microsemi.com/soc/documents/DesignSecurity_WP.pdf

Understanding Actel Antifuse Device Security

<http://www.microsemi.com/soc/documents/AntifuseSecurityWP.pdf>

RTAX-S/SL Testing and Reliability Update

http://www.microsemi.com/soc/documents/RTAXS_Rel_Test_WP.pdf

Miscellaneous

Libero IDE flow diagram

<http://www.microsemi.com/soc/products/software/libero/#flow>

5 – Datasheet Information

List of Changes

The following table lists critical changes that were made in each revision of the document.

Revision	Changes	Page
Revision 16 (January 2013)	"EV" Flow (Class V Flow Equivalent Processing) and all references to it were deleted, as RTAX-DSP is now fully qualified with QML Class V per MIL-PRF-38535 (SAR 44010).	N/A
	A link for more information on prototyping solutions was added to the "Low-Cost Prototyping Solutions" section (SAR 38541): www.microsemi.com/soc/products/solutions/milaero/prototypingsolutions.aspx	1-11
	VPUMP was added to Table 2-2 • Absolute Maximum Ratings (SAR 42246).	2-2
	The DEPTH[3:] signal was added to Table 2-101 • RAM Signal Description (SAR 42799).	2-112
	The "Global Set Fuse" section was rewritten, including a reference to a Space Forum presentation (SAR 38541).	2-136
Revision 15 (May 2012)	The maximum number of I/Os for the CG/LG624 package in RTAX250S/SL was corrected from 232 to 248 in the "Device Resources" table (SAR 34359).	iii
	Table 3 • Extended Flow for RTAX-S/SL and RTAX-DSP ^{1, 2, 3, 4} was revised to include a reference to note 5 on the Destructive Bond Pull step, step 1. A missing step 7 was added: Seal (Fine and Gross Leak Test). "Method 2003" was corrected to "Method 2023" in table note 5 (SAR 37426).	vi
	"QML Class V MIL-PRF-38535 Flow" for RTAX-S/SL devices is new (SAR 36697).	vii
	"EV" Flow (Class V Flow Equivalent Processing) for RTAX-DSP devices has been revised (SAR 36697). In Table 5 • "EV" Flow (Class V Equivalent Flow Processing) for RTAX-DSP ^{1, 2, 3} , DSCC was revised to DLA in table note 1 and "Method 2003" was corrected to "Method 2023" in table note 4 (SAR 37426).	viii
	Table 2-4 • RTAX-S Standby Current was corrected. Values of ICCDIFFA for 25°C and 125°C had been reversed for all devices except RTAX4000S (SAR 38027).	2-3
	Table 2-6 • RTAX-DSP Standby Current and Table 2-7 • RTAX-DL Standby Current were updated (SAR 36920).	2-4
	The "VPUMP Supply Voltage (External Pump)" pin description was updated (SAR 37032).	2-14
	The last sentence of the "HCLKA/B/C/D Dedicated (Hardwired) Clocks A, B, C, and D" pin description was revised to state that Microsemi recommends HCLK pins not being used as HCLK inputs or I/Os be tied to a known state (SAR 38535).	2-14
	Table 2-16 • Bank Wide Delay Values was incorrectly referenced in the "PRA/B/C/D Probes A, B, C, and D" section for recommendations on pin status for flight boards. The reference has been corrected to Table 2-117 • JTAG and Probe Pin Recommendations for Flight (SAR 36561).	2-15
	The "TRST Boundary Scan Reset Pin" section was revised to remove the parenthetical statement, "with or without the pull-up resistor" (SAR 34131).	2-15
	Values were added to the global resource timing tables for RTAX2000D and RTAX4000D (1.425 V) in the "Hardwired Clocks" section and "Routed Clocks" section: Table 2-84 through Table 2-86 and Table 2-96 through Table 2-98 (SAR 33519).	2-103, 2-106

Revision	Changes	Page
Revision 15 (continued)	Table 2-106 • Eight RAM Blocks Are Cascaded (Worst-Case Military Conditions VCCA = 1.425 V, VCCI = 3.0 V, TJ = 125°C) and Table 2-107 • Sixteen RAM Blocks Are Cascaded (Worst-Case Military Conditions VCCA = 1.425 V, VCCI = 3.0 V, TJ = 125°C) were updated to account for cross-coupling noise (SAR 36696).	2-118, 2-119
	The "TRST" section was rewritten, noting that the TRST pin must be hardwired to ground for flight (SAR 34131).	2-133
	The "Data Registers (DRs)" section was revised to note the IDCODE and USERCODE registers have 20 bits available for programming (SAR 34512).	2-135
	The "Global Set Fuse" section was revised to clarify the cleared and preset states (SARs 38536, 38541).	2-136
Revision 14 (September 2011)	The DL option was added to the "Ordering Information" section and product tables (SAR 33149).	ii to vii
	The user I/Os for the CQ352 package in RTAX2000D and RTAX4000D were changed from 150 to 166 in the "Device Resources" section (SAR 31157).	iii
	The "RTAX-S/SL and RTAX-DSP Device Status" table was updated to note that RTAX2000D/DL and RTAX4000D/DL have moved from Preliminary to Production status (SAR 33353). The "Speed Grade and Temperature Grade Matrix" table and "Ordering Information" section now reflect that these devices are available for speed grade –1 (SAR 33148).	iii
	The "Programmable Interconnect Element" section and "Security" section were revised to clarify that although no existing security measures can give an absolute guarantee, Microsemi FPGAs implement the best security available in the industry (SAR 32865).	1-1, 2-136
	Definitions and information about hot-swap and cold-swap was added to the "I/O Logic" section (SAR 31419).	1-6
	P1 and P2 in Figure 1-12 • Mathblocks Cascaded Together as Part of a Complex DSP Function were replaced with CDOUT1 and CDOUT2 (SAR 32581).	1-8
	Figure 2-1 • Use of an External Resistor for 5 V Tolerance was revised to show the VCCI and GND clamp diodes. The explanatory text above the figure was revised as well (SAR 29699).	2-1
	In Table 2-2 • Absolute Maximum Ratings, the VCCA limits were changed from "–0.3 to 1.6" to "–0.3 to 1.7" (SAR 30847). The VI limits were changed from "–0.5 to 3.75" to "–0.5 to 4.1" (SAR 29757). A note was added to the table for VCCI stating, "The absolute maximum ratings of VCCI are applicable to all I/O standards supported by the device" (SAR 31241).	2-2
	Values for RTAX2000D were added to Table 2-6 • RTAX-DSP Standby Current (SAR 33286). Table 2-7 • RTAX-DL Standby Current is new (SAR 33149).	2-4
	In Table 2-9 • Different Components Contributing to the Total Power Consumption in RTAX-S/SL/DSP Devices, the P1 value for RTAX4000D was corrected from 7000 to 700.0 (SAR 29953). P13 through P17 were added to the table (SAR 30059).	2-6
	$P_{\text{MathBlock}}$ was added to the power calculation formulas (SAR 30059).	2-7
	A value for θ_{jc} was added to Table 2-10 • Package Thermal Characteristics and note 4 was revised to include θ_{jc} . "Free convection = 0" was removed from "Sample Case 1" and "Sample Case 2" (SAR 33910).	2-9, 2-10
	The following text was added to the "User-Defined Supply Pins" section (SAR 24308): The user does not need to assign VREF pins for OUTBUF and TRIBUF. VREF pins are needed only for input and bidirectional I/Os.	2-14
	In the Introduction to the "User I/Os" section, the following sentence was added to clarify the slew rate setting (SAR 29760): The slew rate setting is effective for both rising and falling edges.	2-16

Revision	Changes	Page
Revision 14 (continued)	The following sentence was added for clarification in the "Using the Weak Pull-Up and Pull-Down Circuits" section (SAR 31246):	2-20
	The weak pull-up and pull-down is active only when the device is powered-up.	
	Reference to Table 2-21 • I/O Weak Pull-Up/Pull-Down Resistances¹ replaced the statement of "on the order of 10 kΩ" (SAR 28695).	
	Additional information was added to clarify how the weak pull-up and pull-down resistors are physically implemented (SAR 32714).	
	Figure 2-11 • Timing Model was replaced (SAR 33043).	2-28
	The note in Table 2-16 • Bank Wide Delay Values was revised to reflect that the values in the table apply not only to RTAX2000S/SL but to all RTAX-DSP and RTAX-S devices (SAR 32491).	2-21
	The description for the C _{INCLK} parameter in Table 2-20 • Input Capacitance was changed from "Input capacitance on clock pin" to "Input capacitance on HCLK and RCLK pin" (SAR 31245).	2-26
	In Table 2-21 • I/O Weak Pull-Up/Pull-Down Resistances¹ , notes 2 and 3 were corrected to give formulas for R _(WEAK PULL-UP-MAX) and R _(WEAK PULL-DOWN-MAX) rather than R _(PULL-UP-MAX) and R _(PULL-DOWN-MAX) and the note regarding output buffers was removed as not applicable (SARs 29301, 32285).	2-26
	Two parameter names were corrected in Figure 2-10 • Output Buffer Delays . One occurrence of t _{ENLZ} was changed to t _{ENZL} and one occurrence of t _{ENHZ} was changed to t _{ENZH} (SAR 33315).	2-27
	The definitions for t _{ENZL} and t _{ENHZ} were corrected in Table 2-25 • Worst-Case Military Conditions VCCA = 1.425 V, VCCI = 3.0 V, TJ = 125°C through Table 2-38 • Worst-Case Military Conditions VCCA = 1.425 V, VCCI = 3.0 V, TJ = 125°C (SAR 33315).	2-31 through 2-66
	Previous definitions: t _{ENZL} – Enable to Pad delay through the Output Buffer—High to Z t _{ENHZ} – Enable to Pad delay through the Output Buffer—Z to Low Corrected definitions: t _{ENZL} – Enable to Pad delay through the Output Buffer—Z to Low t _{ENHZ} – Enable to Pad delay through the Output Buffer—High to Z	
	The minimum VIL for 1.5 V LVCMOS was corrected from –0.5 to –0.3 in Table 2-32 • DC Input and Output Levels (SAR 34280).	2-55
	The minimum VIL for 3.3 V PCI was corrected from –0.5 to –0.3 in Table 2-35 • DC Input and Output Levels (SAR 34280).	2-64
	The enable signal in Figure 2-36 • R-Cell Delays was corrected to show it is active low rather than active high (SAR 32428).	2-91
	The "Global Resource Distribution" section previously stated, "24 segments per HCLK driving north-south and 28 segments per CLK driving east-west per core tile." This text was removed and replaced by a reference to the RTAX-S/SL Clocking Resource and Implementation application note (SAR 28040).	2-108
	Package names used in the "Package Pin Assignments" section were revised to match standards given in Package Mechanical Drawings (SAR 27395).	3-1
	Bank numbers were added to the following pin tables for RTAX-DSP packages (SAR 28992):	
	"CQ352" for RTAX2000D	3-26
	"CQ352" for RTAX4000D	3-30
	"CG1272/LG1272" for RTAX2000D	3-79
	"CG1272/LG1272" for RTAX4000D	3-91

Revision	Changes	Page
Revision 13 (August 2010)	The versioning system for datasheets has been changed. Datasheets are assigned a revision number that increments each time the datasheet is revised. The "RTAX-S/SL and RTAX-DSP Device Status" table indicates the status for each device in the device family.	N/A
	References to "Timer" were changed to "SmartTime," which is the current name of the tool.	N/A
	The RTAX-DSP family was added to this datasheet. The RTAX2000D and RTAX4000D devices were included in applicable tables, text, and the "Ordering Information" section.	N/A
	PROTO was added to the "Screening Levels" table for RTAX-S/SL.	ii
	The "Device Resources" table was updated by including a user I/O count of 150 for the CQ352 package, RTAX2000D. Two notes were added to the table: 1. <i>RTAX2000S/SL and RTAX2000D are not pin compatible in the CQ352 package type.</i> 2. <i>The package overhang for RTAX4000D is slightly larger than RTAX4000S/SL, but they are pin compatible.</i>	iii
	The "I/Os per Package" table was updated for CQ352 and CGD1272/LGD1272. The column headings "Differential Pair" and "Pair" were changed to "Adjacent Differential Pairs" and "Non-Adjacent Differential Pairs." Notes were added to the table to define terms and state how to calculate total number of I/Os (SAR 23483).	iv
	Table 2 • MIL-STD-883 Class B Product Flow for RTAX-S/SL and RTAX-DSP^{1, 2} was revised to change the method for Step 4. CQ256 was added to Condition B and LGD1272 was added to Condition A. Table note 3 was revised to state, "Condition A applies to RTAX4000S/SL, RTAX2000D, and RTAX4000D packages only."	v
	Table 3 • Extended Flow for RTAX-S/SL and RTAX-DSP^{1, 2, 3, 4} was revised to change the method for Step 5. CQ256 was added to Condition B and LGD1272 was added to Condition A. Table note 5 was revised to state, "Condition A applies to RTAX4000S/SL, RTAX2000D, and RTAX4000D packages only."	vi
	Table 4 • QML Class V MIL-PRF-38535 Flow for RTAX-S/SL and RTAX-DSP^{1, 2} was revised to change the method for Step 5. CQ256 was added to Condition B and LGD1272 was added to Condition A. Table note 4 was revised to state, "Condition A applies to RTAX4000S/SL, RTAX2000D, and RTAX4000D packages only."	vii
	The "Embedded Memory" section was revised to note that the pipelined register in each memory block is not hardened and susceptible to single-event upsets (SAR 24153).	1-5
	Table 2-1 • I/O Features Comparison was revised to add a clarifying statement to the first table note: In other words, 5 V tolerance and hot-swapping/cold-sparing cannot coexist. Note 2 ("Can be implemented with an external resistor") was indicated as applicable for 3.3 V LVTTTL.	2-1
	The "5 V Tolerance" section was revised to state that the voltage at the input will not be clamped if the VCCI or VCCA are powered off. Previously VCCI only was mentioned (SAR 79584).	2-1
	The VCCA and VI limits were revised in Table 2-2 • Absolute Maximum Ratings .	2-2
	The "Power-Up/Down Sequence" section was updated to add, "During power-down, all RTAX-S/SL and RTAX-DSP I/Os are tristated (SAR 20917). A reference to the Board-Level Considerations for Power-Up and Power-Down of RTAX-S/SL FPGAs application note was included.	2-3
	In Table 2-4 • RTAX-S Standby Current , ICCDIFFA was revised for RTAX2000S, RTAX1000S, and RTAX250S at 125°C.	2-3
In Table 2-8 • Default Clload / VCCI , P10 and PI/O values for Single-Ended with VREF voltages were updated.	2-5	
The core tile RCLK power component was updated for RTAX250S/SL in Table 2-9 • Different Components Contributing to the Total Power Consumption in RTAX-S/SL/DSP Devices (SAR 23848).	2-6	

Revision	Changes	Page
Revision 13 (continued)	"Convection" was changed to "free convection" in "Sample Case 1" and "Sample Case 2".	2-10
	The values in Table 2-11 • Temperature and Voltage Timing Derating Factors were updated.	2-11
	The "Timing Model" was updated (SAR 79604). The calculated results in the "Hardwired Clock" section and "Routed Clock" section were updated to match.	2-12, 2-13
	The "NC No Connection" pin description was revised to state, "This pin is not connected to circuitry within the device, or to any other pin in the package" (SAR 79409).	2-15
	Table 2-14 • Compatible I/O Standards for Different VCCI Values now refers to Table 2-3 • RTAX-S/SL and RTAX-DSP Recommended Operating Conditions for VCCI tolerances rather than stating in a table note that VCCI tolerance is $\pm 5\%$. The example in the paragraphs below the table was modified to use $\pm 5\%$ rather than $\pm 8\%$ VCCI tolerance for LVCMOS.	2-18
	Figure 2-5 • I/O Cluster Interface was revised to add HCLK or RCLK (SAR 21507).	2-20
	Values in the following tables were updated (note that in previous versions of this datasheet, timing numbers were shown for VCCA at 1.4 V):	2-31
	Table 2-25 • Worst-Case Military Conditions VCCA = 1.425 V, VCCI = 3.0 V, TJ = 125°C	2-40
	Table 2-28 • Worst-Case Military Conditions VCCA = 1.425 V, VCCI = 2.3 V, TJ = 125°C	2-48
	Table 2-29 • DC Input and Output Levels (SARs 26059, 79593)	2-49
	Table 2-31 • Worst-Case Military Conditions VCCA = 1.425 V, VCCI = 1.7 V, TJ = 125°C	2-55
	Table 2-32 • DC Input and Output Levels (SAR 79593)	2-56
	Table 2-34 • Worst-Case Military Conditions VCCA = 1.425 V, VCCI = 1.4 V, TJ = 125°C	2-65
	Table 2-37 • Worst-Case Military Conditions VCCA = 1.425 V, VCCI = 3.0 V, TJ = 125°C	2-68
	Table 2-41 • Worst-Case Military Conditions VCCA = 1.425 V, VCCI = 3.0 V, TJ = 125°C	2-70
	Table 2-44 • Worst-Case Military Conditions VCCA = 1.425 V, VCCI = 1.4 V, TJ = 125°C	2-72
	Table 2-47 • Worst-Case Military Conditions VCCA = 1.425 V, VCCI = 2.3 V, TJ = 125°C	2-74
	Table 2-50 • Worst-Case Military Conditions VCCA = 1.425 V, VCCI = 2.3 V, TJ = 125°C	2-76
	Table 2-53 • Worst-Case Military Conditions VCCA = 1.425 V, VCCI = 3.0 V, TJ = 125°C	2-78
	Table 2-56 • Worst-Case Military Conditions VCCA = 1.425 V, VCCI = 3.0 V, TJ = 125°C	2-80
Table 2-59 • Worst-Case Military Conditions VCCA = 1.425 V, VCCI = 2.3 V, TJ = 125°C	2-81	
Table 2-60 • DC Input and Output Levels	2-82	
Table 2-62 • Worst-Case Military Conditions VCCA = 1.425 V, VCCI = 3.0 V, TJ = 125°C	2-84	
Table 2-63 • Worst-Case Military Conditions VCCA = 1.425 V, VCCI = 3.0 V, TJ = 125°C	2-91	
Table 2-64 • Worst-Case Military Conditions VCCA = 1.425 V, VCCI = 3.0 V, TJ = 125°C	2-92	
Table 2-65 • Worst-Case Military Conditions VCCA = 1.425 V, VCCI = 3.0 V, TJ = 125°C		
Figure 2-36 • R-Cell Delays was revised to correct the placement of t_{CLR} (SAR 79526).	2-91	
The "Mathblock Timing Specification" section is new.	2-93	

Revision	Changes	Page
Revision 13 (continued)	Values in the following tables were updated (note that in previous versions of this datasheet, timing numbers were shown for VCCA at 1.4 V):	
	Table 2-74 • RTAX4000S (Worst-Case Military Conditions VCCA = 1.4 V, VCCI = 3.0 V, T _J = 125°C)	2-101
	Table 2-76 • RTAX250S/SL (Worst-Case Military Conditions VCCA = 1.425 V, VCCI = 3.0 V, T _J = 125°C)	2-102
	Table 2-78 • RTAX1000S/SL (Worst-Case Military Conditions VCCA = 1.425 V, VCCI = 3.0 V, T _J = 125°C)	2-102
	Table 2-80 • RTAX2000S/SL (Worst-Case Military Conditions VCCA = 1.425 V, VCCI = 3.0 V, T _J = 125°C)	2-103
	Table 2-82 • RTAX4000S (Worst-Case Military Conditions VCCA = 1.425 V, VCCI = 3.0 V, T _J = 125°C)	2-103
	Table 2-83 • RTAX4000S Worst-Case MPW (VCCA = 1.575 V, VCCI = 3.6 V, T _J = 125°C)	2-106
	Table 2-88 • RTAX250S/SL (Worst-Case Military Conditions VCCA = 1.425 V, VCCI = 3.0 V, T _J = 125°C)	2-106
	Table 2-90 • RTAX1000S/SL (Worst-Case Military Conditions VCCA = 1.425 V, VCCI = 3.0 V, T _J = 125°C)	2-106
	Values in the following tables were updated (note that in previous versions of this datasheet, timing numbers were shown for VCCA at 1.4 V):	
	Table 2-92 • RTAX2000S/SL (Worst-Case Military Conditions VCCA = 1.425 V, VCCI = 3.0 V, T _J = 125°C)	2-103
	Table 2-93 • RTAX2000S/SL Worst-Case MPW (VCCA = 1.575 V, VCCI = 3.6 V, T _J = 125°C)	2-105
	Table 2-94 • RTAX4000S (Worst-Case Military Conditions VCCA = 1.425 V, VCCI = 3.0 V, T _J = 125°C)	2-105
	Table 2-95 • RTAX4000S Worst-Case MPW (VCCA = 1.575 V, VCCI = 3.6 V, T _J = 125°C)	2-106
	Figure 2-55 • RAM Read Timing Waveforms was revised to interchange the captions for t _{RCK2RD1} and t _{RCK2RD2} (SAR 24794).	2-114
	The timing tables in the RAM "Timing Characteristics" section were updated.	2-115
The timing tables in the FIFO "Timing Characteristics" section were updated.	2-126	
The configuration information for PRA/B/C/D was revised in Table 2-117 • JTAG and Probe Pin Recommendations for Flight (SAR 79412).	2-134	
The IDCODE length and USERCODE length for different devices were specified in the "Data Registers (DRs)" section (SAR 26407).	2-135	
The "CQ352" and "CG1272/LG1272" pin tables for RTAX2000D and RTAX4000D are new.	3-26, 3-79	
v5.4 (May 2009)	RTAX4000S now supports the low-power grade option. In addition, this device has moved from a preliminary state to a production state.	N/A
	RTAX250S/SL supports 624-CCGA/LGA. The following tables were updated: Table 1 • RTAX Family Product Profile, "Screening Levels", "Ordering Information".	N/A
	All DC input and output tables and timing characteristic tables were updated.	N/A
	The "Ordering Information" section was updated. B was deleted from the Package Type and the speed grade description was updated.	ii
	The "Screening Levels" table note was updated.	ii
	The "Speed Grade and Temperature Grade Matrix" table was updated.	iii
	The "I/Os per Package" table is new.	iv

Revision	Changes	Page
v5.4 (continued)	In Table 2 • MIL-STD-883 Class B Product Flow for RTAX-S/SL and RTAX-DSP ^{1, 2} , "TBD" in step 4 was changed to "Condition A".	v
	In Table 3 • Extended Flow for RTAX-S/SL and RTAX-DSP ^{1, 2, 3, 4} , "TBD" in step 4 was changed to "Condition A".	vi
	The first paragraph of the "General Description" section originally stated there were two million equivalent system gates; this has been corrected to four million equivalent system gates.	1-1
	Information about segmenting clocks was added to the "Design Environment" section.	1-11
	The "Prototyping with ProASIC3E Reprogrammable Units" section is new.	1-12
	In Table 2-1 • I/O Features Comparison, LVTTTL was updated. Note 1 was updated and note 4 is new.	2-1
	In Table 2-2 • Absolute Maximum Ratings, the limit for V_I was changed from 4.0 to 4.1 and V_{PUMP} was added to the table.	2-2
	The "5 V Tolerance" section was significantly updated.	2-1
	RTAX4000S/SL data was updated in Table 2-4 • RTAX-S Standby Current. For RTAX2000S/SL, $I_{CCDIFFA}$ was changed from 2.96 to 3.13. The I_{IL}/I_{IH} heading was changed to I_{IH} , I_{IL} , or I_{OZ} . Note 1 is new.	2-3
	RTAX4000S/SL data was added to Table 2-5 • RTAX-SL Standby Current. I_{CCA} data was updated for Typical 25°C for RTAX2000S/SL, RTAX1000S/SL, and RTAX250S/SL. The I_{IL}/I_{IH} heading was changed to I_{IH} , I_{IL} , or I_{OZ} . Note 1 is new.	2-4
	Table 2-8 • Default Clod / VCCI was significantly updated.	2-5
	In the "Ptotal = Pdc + Pac" section, P_{DC} definition, N_{banks} was deleted.	2-7
	In the "Power Estimation Example" section, P_{DC} definition, N_{banks} was deleted.	2-8
	Table 2-10 • Package Thermal Characteristics was updated to include 624-pin CCGA/LGA	2-9
	Table 2-11 • Temperature and Voltage Timing Derating Factors was significantly updated.	2-11
	In the "Hardwired Clock" section, the Clock-to-Out (Pad-to-Pad) was updated. T_{RCO} was changed from 0.9 to 0.96.	2-13
	In the "Routed Clock" section, the Clock-to-Out (Pad-to-Pad) was updated. T_{RCO} was changed from 0.9 to 0.96. Footnote 1 is new.	2-13
	The "VCCIBx Supply Voltage" section was updated to include information about unused banks.	2-14
	The "HCLKA/B/C/D Dedicated (Hardwired) Clocks A, B, C, and D" section was updated.	2-14
	The "VPUMP Supply Voltage (External Pump)" section was updated.	2-14
	The "CLKE/F/G/H Global Clocks E, F, G, and H" section was updated.	2-14
	The "PRA/B/C/D Probes A, B, C, and D" section was updated.	2-15
	Information about SEUs and cell buffers was added to "Introduction" section.	2-16
	In Table 2-17 • Macros for Single-Ended I/O Standards, the macro names for LVTTTL were changed from $_H_$ to $_F_$	2-23
	The "Customizing the I/O" section was updated. Table 2-16 • Bank Wide Delay Values is new.	2-21
	The data in Table 2-21 • I/O Weak Pull-Up/Pull-Down Resistances ¹ was significantly updated. Notes 1, 2, and 3 were also updated.	2-26
	The note was updated to include pin compatibility information for "CQ352".	3-8
	The note was updated to include pin compatibility information for "CG624/LG624". the RTAX250S/SL pin table is new.	3-34

Revision	Changes	Page
v5.4 (continued)	The "CQ352" table for the RTAX250S/SL device is new.	3-10
	In Table 2-23 • DC Input and Output Levels, the footnote is new.	2-30
	In Table 2-38 • Worst-Case Military Conditions VCCA = 1.425 V, VCCI = 3.0 V, TJ = 125°C, the footnote is new.	2-66
	Table 2-56 • Worst-Case Military Conditions VCCA = 1.425 V, VCCI = 3.0 V, TJ = 125°C was significantly updated.	2-78
	Table 2-28 • Worst-Case Military Conditions VCCA = 1.425 V, VCCI = 2.3 V, TJ = 125°C to Table 2-107 • Sixteen RAM Blocks Are Cascaded (Worst-Case Military Conditions VCCA = 1.425 V, VCCI = 3.0 V, TJ = 125°C) were updated.	2-40 to 2-119
	Table 2-111 • One FIFO Block (Worst-Case Military Conditions VCCA = 1.425 V, VCCI = 3.0 V, TJ = 125°C) to Table 2-116 • JTAG Instruction Code were updated.	2-128 to 2-133
	In the "RTAX2000S/SL Function" table, the block numbers were removed. For example "Bank 0, Block 0" was changed to "Bank 0".	3-5
v5.3 (October 2008)	In Table 2-5 • RTAX-SL Standby Current, the I _{CCA} specifications were updated for 125°C.	2-4
v5.2 (August 2007)	The "I/O Logic" section was updated to include information about user flip-flops being immune to SEU.	1-6
	The "Low-Cost Prototyping Solutions" section was updated significantly.	1-11
	Table 2-4 • RTAX-S Standby Current was updated to include I _{IH} /I _{IL} .	2-3
	Table 2-5 • RTAX-SL Standby Current was updated to include I _{IH} /I _{IL} .	2-4
	The CG1272 was updated in the Table 2-10 • Package Thermal Characteristics.	2-9
	The temperature in note 1 was changed from 175 to 125 in the Table 2-11 • Temperature and Voltage Timing Derating Factors.	2-11
	In the "Timing Model", the Hardwired Clock was changed to Routed or Hardwired.	2-12
v5.1 (August 2007)	The "Ordering Information" section was updated to include the Sigma Six Column and BAE Column designation. A note was added to the "Screening Levels" table regarding the Sigma Six Column and BAE Column.	ii
v5.0 (June 2007)	RTAX-SL information is new.	N/A
	EV Flow (Class V Flow Equivalent Processing) information is new.	N/A
	The "Ordering Information" section was updated.	ii
	The "MIL-STD-883 Class B Product Flow" table was updated.	v
	The "Extended Flow" table was updated.	vi
	The "Low-Cost Prototyping Solutions" section was updated to include RTAX-SL prototyping information.	1-11
	Table 2-5 • RTAX-SL Standby Current is new.	2-4
	In the "Sample Case 2" section, θ_{cb} was changed to T _j .	2-10
	The Axcelerator figure listed below the "VCCDA Supply Voltage" section was incorrect and has been removed from the datasheet.	2-14
	The "CQ256" table for the RTAX2000S/SL device is new.	3-5

Revision	Changes	Page
v4.0 (May 2007)	All information regarding the RTAX4000S device is new.	N/A
	The "Timing Model" was updated.	2-12
	The "Specifications" section was updated.	i
	The SEL and SET information was updated in the "Designed for Space" section.	i
	The maximum I/O counts for the RTAX250S and RTAX1000S were updated in Table 1 • RTAX Family Product Profile.	i
	The "Device Resources" table was updated for CG1272/LG1272.	iii
	The <i>RTAX-S/SL Testing and Reliability Update</i> white paper was added to the "White Papers" section.	4-1
	The "User I/Os" section was updated with information on configuring unused I/Os.	2-16
	Implementing DDR was updated in the "Using DDR (Double Data Rate)" section.	2-22
	PSET was changed to PRE and D was changed to E in Figure 2-6 • DDR Register.	2-22
	The "JTAG" section was updated with JTAG pin information.	2-133
	Figure 2-1 • Use of an External Resistor for 5 V Tolerance was updated.	2-1
	Note 2 in Table 2-2 • Absolute Maximum Ratings was updated.	2-2
	The "Calculating Power Dissipation" section was updated.	2-3
	Table 2-28 • Worst-Case Military Conditions $V_{CCA} = 1.425\text{ V}$, $V_{CCI} = 2.3\text{ V}$, $T_J = 125^\circ\text{C}$ was updated.	2-40
	The "Hardwired Clock" and "Routed Clock" equations were updated.	2-13
	Table 2-4 • RTAX-S Standby Current was updated.	2-3
	Table 2-8 • Default Clload / VCCI was updated.	2-5
	Table 2-11 • Temperature and Voltage Timing Derating Factors was updated.	2-11
	All timing characteristic tables were updated.	N/A
The "CQ352" table for the RTAX4000S is new.	3-22	
The "CG1272/LG1272" table for the RTAX4000S is new.	3-66	
v3.0 (September 2006)	All Timing Characteristics tables were updated.	N/A
	Cold Sparring was added to the Hot Insertion heading in Table 2-1 • I/O Features Comparison.	2-1
	The "Thermal Characteristics" section was updated.	2-9
	The "Simultaneous Switching Outputs (SSO)" section was updated.	2-17
	The "Timing Model" has been updated.	2-12
	The "Hardwired Clock" and "Routed Clock" equations were updated.	2-13
	Table 2-8 • Default Clload / VCCI was updated.	2-5
	Table 2-21 • I/O Weak Pull-Up/Pull-Down Resistances ¹ is new.	2-26
A note was added to Table 2-60 • DC Input and Output Levels.	2-81	

Revision	Changes	Page
v2.2 (May 2006)	The LVDS Capable I/O specification was added to "Leading-Edge Performance".	i-i
	Table 1 • RTAX Family Product Profile was updated to include CQ256.	i
	CQ256 was added to the "Screening Levels" table.	ii
	CQ256 is new and CQ352 for the RTAX1000S device was updated in the "Device Resources" table.	iii
	The "Overshoot/Undershoot Limits" section is new.	2-3
	Table 2-2 • Absolute Maximum Ratings was updated.	2-2
	Table 2-3 • RTAX-S/SL and RTAX-DSP Recommended Operating Conditions was updated.	2-2
	The "Timing Model" has been updated.	2-12
	The "Hardwired Clock" and "Routed Clock" equations were updated.	2-13
	This sentence was updated in the "CLKE/F/G/H Global Clocks E, F, G, and H" section: When the CLK pins are unused, Microsemi recommends that they are tied to a known state.	2-14
	Figure 2-27 • LVPECL Circuit was updated. The following labels were corrected: INBUF_LVPECL OUTBUF_LVPECL	2-81
	The following sentence was removed from the "Global Resource Distribution" section: "An unused input can be tied to ground for power savings."	2-108
	The "RAM" section was updated.	2-111
	The "CQ256" package figure and is new.	3-4
v2.1 (October 2005)	In Table 2-4 • RTAX-S Standby Current, the I_{CCA} column heading was changed to I_{CCDA} and note 3 is new.	2-3
v2.0	The "Designed for Space" section was updated.	i
	Table 1 • RTAX Family Product Profile was updated to include 1152 CCGA/LGA.	i
	The "Screening Levels" table was updated to include the 1152 CCGA.	iii
	The RTAX1000S and the RTAX2000S columns were updated in the "Device Resources" table.	iii
	Figure 1-15 • Probe Setup RTAX-S/SL and RTAX-DSP was updated and a note was added to the figure.	1-13
	Table 2-4 • RTAX-S Standby Current was updated. The LVPECL and LVDS specifications were updated. A note was also added to the table.	2-3
	The "Global Resource Access Macros" section was updated.	2-110
	The "JTAG" section section was updated.	2-133
	In the "Data Registers (DRs)" section, the IDCODE and USERCODE were changed from 32 bits to 33 bits.	2-135
	150°C was changed to 125°C in the "Thermal Characteristics" section.	2-9
	Table 2-10 • Package Thermal Characteristics was updated to include the 1152 CCGA. Values in the table were updated.	2-9
	A note was added to the "FIFO" section section.	2-120
	Table 2-9 • Different Components Contributing to the Total Power Consumption in RTAX-S/SL/DSP Devices was updated.	2-6
	Table 2-21 • I/O Weak Pull-Up/Pull-Down Resistances ¹ was updated.	2-26

Revision	Changes	Page
v2.0 (continued)	All Timing Characteristic tables from Table 2-25 • Worst-Case Military Conditions VCCA = 1.425 V, VCCI = 3.0 V, T _J = 125°C to Table 2-101 • RAM Signal Description were updated.	2-31 to 2-112
	In the "MIL-STD-883 Class B Product Flow" table, #3 for the 883 Method was updated. A note was also added to the table.	v
	In the "Extended Flow" table, #5 for the Method column was updated. The notes were also added to the table.	vi
	In the "Pin Descriptions" section section, the descriptions for the "HCLKA/B/C/D Dedicated (Hardwired) Clocks A, B, C, and D" and "CLKE/F/G/H Global Clocks E, F, G, and H" were updated.	2-14
	A footnote was added to the "PRA/B/C/D Probes A, B, C, and D", "TCK2 Test Clock", "TDI2 Test Data Input", and "TDI2 Test Data Input" descriptions.	2-15
	The "CG1152/LG1152" section is new.	3-53
Advance v0.5	LET _{TH} values for SEU and SEL updated under "Designed for Space".	i-i
	"Ordering Information" was updated/ The "Screening Levels", "Speed Grade and Temperature Grade Matrix" tables are new and the "Device Resources" was updated.	i-ii
	Sections "MIL-STD-883 Class B Product Flow" and "Extended Flow" are new.	v, vi
	"General Description" was updated.	1-1
	Table 2-9 • Different Components Contributing to the Total Power Consumption in RTAX-S/SL/DSP Devices was updated.	2-6
	The "Thermal Characteristics" section was updated.	2-9
	Figure 2-4 • Timing Model, the "Hardwired Clock" section and the "Routed Clock" section were updated.	2-12
	The "Introduction" section under "User I/Os" was updated to give details regarding VREF usage.	2-16
	The "Simultaneous Switching Outputs (SSO)" section under "User I/Os" was updated.	2-17
	"Using DDR (Double Data Rate)" section is new.	2-22
	Table 2-20 • Input Capacitance was updated.	2-26
	All Timing Characteristic Tables were updated.	2-31 to 2-132
	The "Introduction" section was updated.	2-16
	The "SEU Hardened D Flip-Flop (DFF)" section was moved under "R-Cell" and updated.	2-89
	The "Global Resource Distribution" section is new.	2-108
	The "Enhancing SEU Performance" section is new.	2-113
	Figure 2-54 • RAM Write Timing Waveforms and Figure 2-55 • RAM Read Timing Waveforms were updated.	2-114
	Figure 2-62 • FIFO Write Timing and Figure 2-63 • FIFO Read Timing were updated.	2-126
	The "Charge Pump Bypass" section is new.	2-133
	The "TRST" section was updated.	2-133
The "Global Set Fuse" section is new.	2-136	
The "CQ208" for both the RTAX250S and RTAX1000S were added.	3-1	
The "CQ352" pin tables for both the RTAX1000S and RTAX2000S were updated.	3-8	
The "CG624/LG624" pin tables for both the RTAX1000S and RTAX2000S were updated.	3-34	

Revision	Changes	Page
Advance v0.4	The "Designed for Space" section was updated.	i
	A new device, the RTAX250S, was added to the "Designed for Space", "Ordering Information", "Screening Levels" and "Device Resources" sections.	i to iii
	2.5V GTL+ support across full military range was removed.	n/a
	Table 1-1 • Number of Core Tiles per Device was updated.	1-4
	Table 2-4 • RTAX-S Standby Current and Table 2-8 • Default Cloud / VCCI were updated.	2-3, 2-5
	Table 2-9 • Different Components Contributing to the Total Power Consumption in RTAX-S/SL/DSP Devices was updated.	2-6
	Table 2-15 • Legal I/O Usage Matrix was updated.	2-19
	Table 2-19 • I/O Macros for Voltage-Referenced I/O Standards	2-24
Advanced v0.3	In the "CQ352" for the RTAX1000S, pin 80 has been changed from VCCI to VCCIB6.	3-14
	In the "CQ208" and "CQ352", the NC (VPP) was changed to NC for all pins.	3-2 to 3-14
Advanced v0.2	The "CQ352" pin table for RTAX1000S is new.	3-10
	Pins 14 and 32 have been changed from VCCA to VCCI for the RTAX2000S in the "CQ352".	3-10
	The "CG624/LG624" for the RTAX1000S is new.	3-47

Datasheet Categories

In order to provide the latest information to designers, some datasheets are published before data has been fully characterized from silicon devices. The data provided for a given device, as highlighted in the "RTAX-S/SL and RTAX-DSP Device Status" table, is designated as either "Product Brief," "Advanced," "Production," and "Datasheet Supplement." The definitions of these categories are as follows:

Product Brief

The product brief is a summarized version of a datasheet (advanced or production) containing general product information. This brief gives an overview of specific device and family information.

Advanced

This datasheet version contains initial estimated information based on simulation, other products, devices, or speed grades. This information can be used as estimates, but not for production.

Production

This datasheet version contains information that is considered to be final.

Datasheet Supplement

The datasheet supplement gives specific device information for a derivative family that differs from the general family datasheet. The supplement is to be used in conjunction with the datasheet to obtain more detailed information and for specifications that do not differ between the two families.

International Traffic in Arms Regulations (ITAR)

The product described in this datasheet are subject to the International Traffic in Arms Regulations (ITAR). They require an approved export license prior to export from the United States. An export includes release of product or disclosure of technology to a foreign national inside or outside the United States.

Safety Critical, Life Support, and High-Reliability Applications Policy

The products described in this advance status document may not have completed the Microsemi qualification process. Products may be amended or enhanced during the product introduction and qualification process, resulting in changes in device functionality or performance. It is the responsibility of each customer to ensure the fitness of any product (but especially a new product) for a particular purpose, including appropriateness for safety-critical, life-support, and other high-reliability applications. Consult the Microsemi SoC Products Group Terms and Conditions for specific liability exclusions relating to life-support applications. A reliability report covering all of the SoC Products Group's products is available at http://www.microsemi.com/soc/documents/ORT_Report.pdf. Microsemi also offers a variety of enhanced qualification and lot acceptance screening procedures. Contact your local sales office for additional reliability information.



Microsemi Corporate Headquarters
One Enterprise Drive, Aliso Viejo CA 92656
Within the USA: (800) 713-4113
Outside the USA: (949) 221-7100
Fax: (949) 756-0308 · www.microsemi.com

Microsemi Corporation (NASDAQ: MSCC) offers a comprehensive portfolio of semiconductor solutions for: aerospace, defense and security; enterprise and communications; and industrial and alternative energy markets. Products include high-performance, high-reliability analog and RF devices, mixed signal and RF integrated circuits, customizable SoCs, FPGAs, and complete subsystems. Microsemi is headquartered in Aliso Viejo, Calif. Learn more at www.microsemi.com.

© 2013 Microsemi Corporation. All rights reserved. Microsemi and the Microsemi logo are trademarks of Microsemi Corporation. All other trademarks and service marks are the property of their respective owners.