



**Please note that Cypress is an Infineon Technologies Company.**

The document following this cover page is marked as “Cypress” document as this is the company that originally developed the product. Please note that Infineon will continue to offer the product to new and existing customers as part of the Infineon product portfolio.

**Continuity of document content**

The fact that Infineon offers the following product as part of the Infineon product portfolio does not lead to any changes to this document. Future revisions will occur when appropriate, and any changes will be set out on the document history page.

**Continuity of ordering part numbers**

Infineon continues to support existing part numbers. Please continue to use the ordering part numbers listed in the datasheet for ordering.

**F<sup>2</sup>MC-16FX 16-bit Microcontroller**

CY966C0 series is based on Cypress's advanced F<sup>2</sup>MC-16FX architecture (16-bit with instruction pipeline for RISC-like performance). The CPU uses the same instruction set as the established F<sup>2</sup>MC-16LX family thus allowing for easy migration of F<sup>2</sup>MC-16LX Software to the new F<sup>2</sup>MC-16FX products. F<sup>2</sup>MC-16FX product improvements compared to the previous generation include significantly improved performance - even at the same operation frequency, reduced power consumption and faster start-up time. For high processing speed at optimized power consumption an internal PLL can be selected to supply the CPU with up to 32MHz operation frequency from an external 4MHz to 8MHz resonator. The result is a minimum instruction cycle time of 31.2ns going together with excellent EMI behavior. The emitted power is minimized by the on-chip voltage regulator that reduces the internal CPU voltage. A flexible clock tree allows selecting suitable operation frequencies for peripheral resources independent of the CPU speed.

**Features****Technology**

0.18μm CMOS

**CPU**

- F<sup>2</sup>MC-16FX CPU
- Optimized instruction set for controller applications (bit, byte, word and long-word data types, 23 different addressing modes, barrel shift, variety of pointers)
- 8-byte instruction queue
- Signed multiply (16-bit × 16-bit) and divide (32-bit/16-bit) instructions available

**System Clock**

- On-chip PLL clock multiplier (×1 to ×8, ×1 when PLL stop)
- 4MHz to 8MHz crystal oscillator (maximum frequency when using ceramic resonator depends on Q-factor)
- Up to 8MHz external clock for devices with fast clock input feature
- 32.768kHz subsystem quartz clock
- 100kHz/2MHz internal RC clock for quick and safe startup, clock stop detection function, watchdog
- Clock source selectable from mainclock oscillator, subclock oscillator and on-chip RC oscillator, independently for CPU and 2 clock domains of peripherals
- The subclock oscillator is enabled by the Boot ROM program controlled by a configuration marker after a Power or External reset
- Low Power Consumption - 13 operating modes (different Run, Sleep, Timer, Stop modes)

**On-Chip Voltage Regulator**

Internal voltage regulator supports a wide MCU supply voltage range (Min=2.7V), offering low power consumption

**Low Voltage Detection Function**

Reset is generated when supply voltage falls below programmable reference voltage

**Code Security**

Protects Flash Memory content from unintended read-out

**DMA**

Automatic transfer function independent of CPU, can be assigned freely to resources

**Interrupts**

- Fast Interrupt processing
- 8 programmable priority levels
- Non-Maskable Interrupt (NMI)

**CAN**

- Supports CAN protocol version 2.0 part A and B
- ISO16845 certified
- Bit rates up to 1Mbps
- 32 message objects
- Each message object has its own identifier mask
- Programmable FIFO mode (concatenation of message objects)
- Maskable interrupt
- Disabled Automatic Retransmission mode for Time Triggered CAN applications
- Programmable loop-back mode for self-test operation

**USART**

- Full duplex USARTs (SCI/LIN)
- Wide range of baud rate settings using a dedicated reload timer
- Special synchronous options for adapting to different synchronous serial protocols

- LIN functionality working either as master or slave LIN device
- Extended support for LIN-Protocol to reduce interrupt load

### I<sup>2</sup>C

- Up to 400kbps
- Master and Slave functionality, 7-bit and 10-bit addressing

### A/D Converter

- SAR-type
- 8/10-bit resolution
- Signals interrupt on conversion end, single conversion mode, continuous conversion mode, stop conversion mode, activation by software, external trigger, reload timers and PPGs
- Range Comparator Function
- Scan Disable Function
- ADC Pulse Detection Function

### Source Clock Timers

Three independent clock timers (23-bit RC clock timer, 23-bit Main clock timer, 17-bit Sub clock timer)

### Hardware Watchdog Timer

- Hardware watchdog timer is active after reset
- Window function of Watchdog Timer is used to select the lower window limit of the watchdog interval

### Reload Timers

- 16-bit wide
- Prescaler with  $1/2^1$ ,  $1/2^2$ ,  $1/2^3$ ,  $1/2^4$ ,  $1/2^5$ ,  $1/2^6$  of peripheral clock frequency
- Event count function

### Free-Running Timers

- Signals an interrupt on overflow, supports timer clear upon match with Output Compare (0, 4)
- Prescaler with 1,  $1/2^1$ ,  $1/2^2$ ,  $1/2^3$ ,  $1/2^4$ ,  $1/2^5$ ,  $1/2^6$ ,  $1/2^7$ ,  $1/2^8$  of peripheral clock frequency

### Input Capture Units

- 16-bit wide
- Signals an interrupt upon external event
- Rising edge, Falling edge or Both (rising & falling) edges sensitive

### Output Compare Units

- 16-bit wide
- Signals an interrupt when a match with Free-running Timer occurs

- A pair of compare registers can be used to generate an output signal

### Programmable Pulse Generator

- 16-bit down counter, cycle and duty setting registers
- Can be used as  $2 \times 8$ -bit PPG
- Interrupt at trigger, counter borrow and/or duty match
- PWM operation and one-shot operation
- Internal prescaler allows 1, 1/4, 1/16, 1/64 of peripheral clock as counter clock or of selected Reload timer underflow as clock input
- Can be triggered by software or reload timer
- Can trigger ADC conversion
- Timing point capture
- Start delay

### Quadrature Position/Revolution Counter (QPRC)

- Up/down count mode, Phase difference count mode, Count mode with direction
- 16-bit position counter
- 16-bit revolution counter
- Two 16-bit compare registers with interrupt
- Detection edge of the three external event input pins AIN, BIN and ZIN is configurable

### LCD Controller

- LCD controller with up to  $4\text{COM} \times 44\text{SEG}$
- Internal or external voltage generation
- Duty cycle: Selectable from options: 1/2, 1/3 and 1/4
- Fixed 1/3 bias
- Programmable frame period
- Clock source selectable from four options (main clock, peripheral clock, subclock or RC oscillator clock)
- Internal divider resistors or external divider resistors
- On-chip data memory for display
- LCD display can be operated in Timer Mode
- Blank display: selectable
- All SEG, COM and V pins can be switched between general and specialized purposes

### Sound Generator

- 8-bit PWM signal is mixed with tone frequency from 16-bit reload counter
- PWM clock by internal prescaler: 1, 1/2, 1/4, 1/8 of peripheral clock

### Real Time Clock

- Operational on main oscillation (4MHz), sub oscillation (32kHz) or RC oscillation (100kHz/2MHz)
- Capable to correct oscillation deviation of Sub clock or RC oscillator clock (clock calibration)
- Read/write accessible second/minute/hour registers
- Can signal interrupts every half second/second/minute/hour/day
- Internal clock divider and prescaler provide exact 1s clock

### External Interrupts

- Edge or Level sensitive
- Interrupt mask bit per channel
- Each available CAN channel RX has an external interrupt for wake-up
- Selected USART channels SIN have an external interrupt for wake-up

### Non Maskable Interrupt

- Disabled after reset, can be enabled by Boot-ROM depending on ROM configuration block
- Once enabled, cannot be disabled other than by reset
- High or Low level sensitive
- Pin shared with external interrupt 0

### I/O Ports

- Most of the external pins can be used as general purpose I/O
- All push-pull outputs (except when used as I<sup>2</sup>C SDA/SCL line)
- Bit-wise programmable as input/output or peripheral signal
- Bit-wise programmable input enable
- One input level per GPIO-pin (either Automotive or CMOS hysteresis)
- Bit-wise programmable pull-up resistor
- Some pins offer high current output capability for LED driving.

### Built-in On Chip Debugger (OCD)

- One-wire debug tool interface
- Break function:

- Hardware break: 6 points (shared with code event)
- -Software break: 4096 points

- Event function
  - Code event: 6 points (shared with hardware break)
  - -Data event: 6 points
  - Event sequencer: 2 levels + reset
- Execution time measurement function
- Trace function: 42 branches
- Security function

### Flash Memory

- Dual operation flash allowing reading of one Flash bank while programming or erasing the other bank
- Command sequencer for automatic execution of programming algorithm and for supporting DMA for programming of the Flash Memory
- Supports automatic programming, Embedded Algorithm
- Write/Erase/Erase-Suspend/Resume commands
- A flag indicating completion of the automatic algorithm
- Erase can be performed on each sector individually
- Sector protection
- Flash Security feature to protect the content of the Flash
- Low voltage detection during Flash erase or write

## Contents

<b>1. Product Lineup</b> .....	<b>5</b>
<b>2. Block Diagram</b> .....	<b>6</b>
<b>3. Pin Assignment</b> .....	<b>7</b>
<b>4. Pin Description</b> .....	<b>8</b>
<b>5. Pin Circuit Type</b> .....	<b>10</b>
<b>6. I/O Circuit Type</b> .....	<b>14</b>
<b>7. Memory Map</b> .....	<b>21</b>
<b>8. RAMSTART Addresses</b> .....	<b>22</b>
<b>9. User ROM Memory Map for Flash Devices</b> .....	<b>23</b>
<b>10. Serial Programming Communication Interface</b> .....	<b>24</b>
<b>11. Interrupt Vector Table</b> .....	<b>25</b>
<b>12. Handling Precautions</b> .....	<b>29</b>
12.1 Precautions for Product Design.....	29
12.2 Precautions for Package Mounting.....	30
12.3 Precautions for Use Environment.....	31
<b>13. Handling Devices</b> .....	<b>32</b>
<b>14. Electrical Characteristics</b> .....	<b>36</b>
14.1 Absolute Maximum Ratings.....	36
14.2 Recommended Operating Conditions.....	39
14.3 DC Characteristics.....	40
14.3.1 Current Rating.....	40
14.3.2 Pin Characteristics.....	44
14.4 AC Characteristics.....	47
14.4.1 Main Clock Input Characteristics.....	47
14.4.2 Sub Clock Input Characteristics.....	49
14.4.3 Built-in RC Oscillation Characteristics.....	50
14.4.4 Internal Clock Timing.....	50
14.4.5 Operating Conditions of PLL.....	51
14.4.6 Reset Input.....	51
14.4.7 Power-on Reset Timing.....	52
14.4.8 USART Timing.....	53
14.4.9 External Input Timing.....	55
14.4.10 I <sup>2</sup> C Timing.....	56
14.5 A/D Converter.....	57
14.5.1 Electrical Characteristics for the A/D Converter.....	57
14.5.2 Accuracy and Setting of the A/D Converter Sampling Time.....	58
14.5.3 Definition of A/D Converter Terms.....	59
14.6 High Current Output Slew Rate.....	61
14.7 Low Voltage Detection Function Characteristics.....	62
14.8 Flash Memory Write/Erase Characteristics.....	64
<b>15. Example Characteristics</b> .....	<b>65</b>
<b>16. Ordering Information</b> .....	<b>68</b>
<b>17. Package Dimension</b> .....	<b>69</b>
<b>18. Major Changes</b> .....	<b>70</b>
<b>Document History</b> .....	<b>71</b>
<b>Sales, Solutions, and Legal Information</b> .....	<b>72</b>

## Product Lineup

Features		CY966C0	Remark
Product Type		Flash Memory Product	
Subclock		Subclock can be set by software	
Dual Operation Flash Memory	RAM	-	
128.5KB + 32KB	8KB	CY96F6C5R, CY96F6C5A	Product Options R: MCU with CAN A: MCU without CAN
256.5KB + 32KB	16KB	CY96F6C6R	
Package		LQFP-120 LQM120	
DMA		4ch	
USART		5ch	LIN-USART 0 to 2/4/5
	with automatic LIN-Header transmission/reception	2ch	LIN-USART 0/1
	with 16 byte RX- and TX-FIFO		
I <sup>2</sup> C		1ch	I <sup>2</sup> C 0
8/10-bit A/D Converter		32ch	AN 0 to 31
	with Data Buffer	No	
	with Range Comparator	Yes	
	with Scan Disable	Yes	
	with ADC Pulse Detection	Yes	
16-bit Reload Timer (RLT)		5ch	RLT 0 to 3/6
16-bit Free-Running Timer (FRT)		2ch	FRT 0/1
16-bit Input Capture Unit (ICU)		8ch (5 channels for LIN-USART)	ICU 0 to 7 (ICU 0/1/4 to 6 for LIN-USART)
16-bit Output Compare Unit (OCU)		4ch	OCU 0 to 3
8/16-bit Programmable Pulse Generator (PPG)		12ch (16-bit) / 24ch (8-bit)	PPG 0 to 7/12 to 15
	with Timing point capture	Yes	
	with Start delay	Yes	
	with Ramp	No	
Quadrature Position/Revolution Counter (QPRC)		2ch	QPRC 0/1
CAN Interface		1ch	CAN 0 32 Message Buffers
External Interrupts (INT)		16ch	INT 0 to 15
Non-Maskable Interrupt (NMI)		1ch	
Sound Generator (SG)		2ch	SG 0/1
LCD Controller		4COM × 44SEG	COM 0 to 3 SEG 0 to 4/7 to 45
Real Time Clock (RTC)		1ch	
I/O Ports		97 (Dual clock mode) 99 (Single clock mode)	
Clock Calibration Unit (CAL)		1ch	
Clock Output Function		2ch	
Low Voltage Detection Function		Yes	Low voltage detection function can be disabled by software
Hardware Watchdog Timer		Yes	
On-chip RC-oscillator		Yes	
On-chip Debugger		Yes	

Note: All signals of the peripheral function in each product cannot be allocated by limiting the pins of package. It is necessary to use the port relocate function of the general I/O port according to your function use.

### 1. Block Diagram

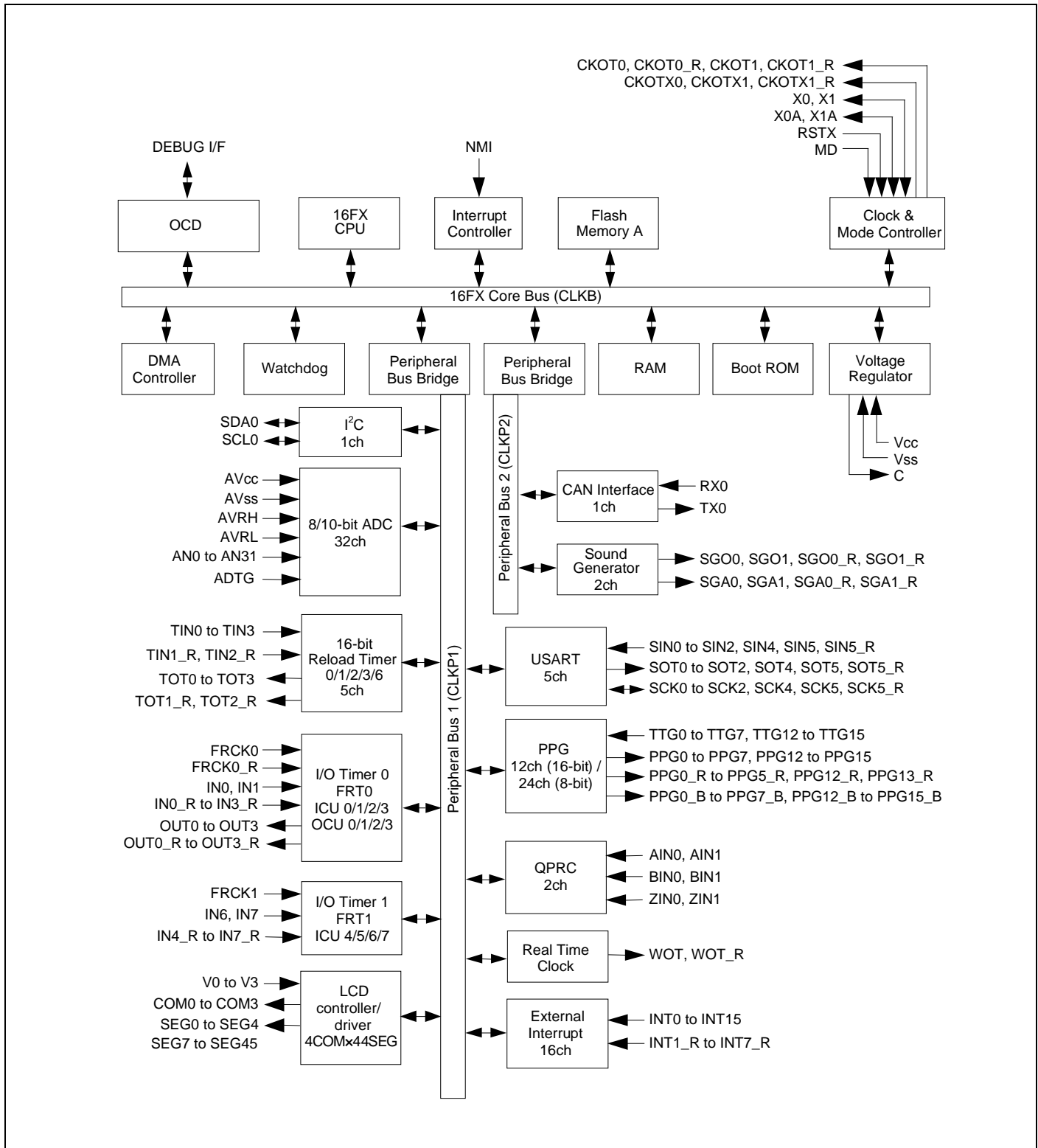

## 2. Pin Assignment

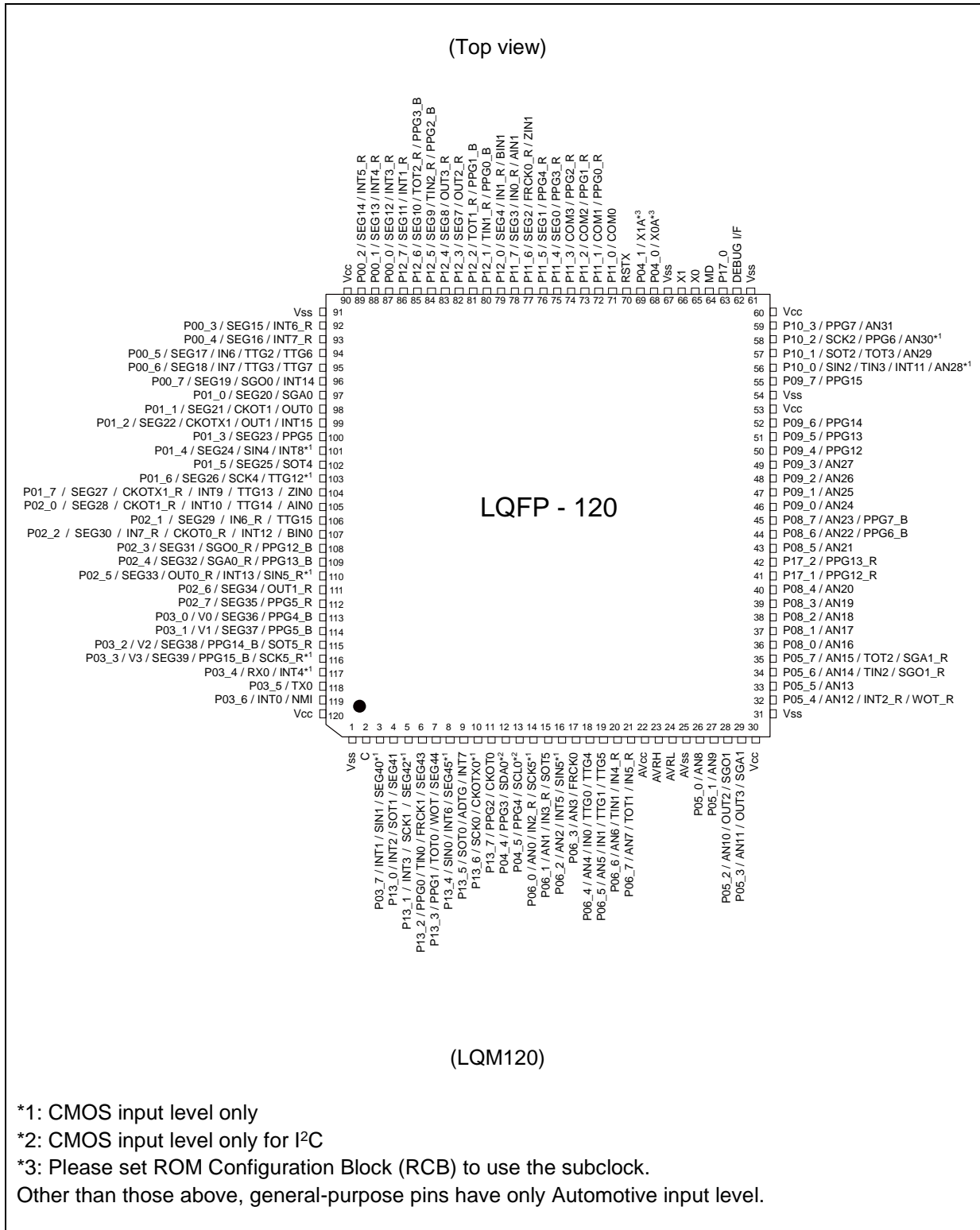

### 3. Pin Description

Pin Name	Feature	Description
ADTG	ADC	A/D converter trigger input pin
AINn	QPRC	Quadrature Position/Revolution Counter Unit n input pin
ANn	ADC	A/D converter channel n input pin
AVcc	Supply	Analog circuits power supply pin
AVRH	ADC	A/D converter high reference voltage input pin
AVRL	ADC	A/D converter low reference voltage input pin
AVss	Supply	Analog circuits power supply pin
BINn	QPRC	Quadrature Position/Revolution Counter Unit n input pin
C	Voltage regulator	Internally regulated power supply stabilization capacitor pin
CKOTn	Clock Output function	Clock Output function n output pin
CKOTn_R	Clock Output function	Relocated Clock Output function n output pin
CKOTXn	Clock Output function	Clock Output function n inverted output pin
CKOTXn_R	Clock Output function	Relocated Clock Output function n inverted output pin
COMn	LCD	LCD Common driver pin
DEBUG I/F	OCD	On Chip Debugger input/output pin
FRCKn	Free-Running Timer	Free-Running Timer n input pin
FRCKn_R	Free-Running Timer	Relocated Free-Running Timer n input pin
INn	ICU	Input Capture Unit n input pin
INn_R	ICU	Relocated Input Capture Unit n input pin
INTn	External Interrupt	External Interrupt n input pin
INTn_R	External Interrupt	Relocated External Interrupt n input pin
MD	Core	Input pin for specifying the operating mode
NMI	External Interrupt	Non-Maskable Interrupt input pin
OUTn	OCU	Output Compare Unit n waveform output pin
OUTn_R	OCU	Relocated Output Compare Unit n waveform output pin
Pnn_m	GPIO	General purpose I/O pin
PPGn	PPG	Programmable Pulse Generator n output pin (16bit/8bit)
PPGn_R	PPG	Relocated Programmable Pulse Generator n output pin (16bit/8bit)
PPGn_B	PPG	Programmable Pulse Generator n output pin (16bit/8bit)
RSTX	Core	Reset input pin
RXn	CAN	CAN interface n RX input pin
SCKn	USART	USART n serial clock input/output pin
SCKn_R	USART	Relocated USART n serial clock input/output pin
SCLn	I <sup>2</sup> C	I <sup>2</sup> C interface n clock I/O input/output pin
SDAn	I <sup>2</sup> C	I <sup>2</sup> C interface n serial data I/O input/output pin
SEGn	LCD	LCD Segment driver pin
SGAn	Sound Generator	Sound Generator amplitude output pin
SGAn_R	Sound Generator	Relocated Sound Generator amplitude output pin
SGOn	Sound Generator	Sound Generator sound/tone output pin
SGOn_R	Sound Generator	Relocated Sound Generator sound/tone output pin

Pin Name	Feature	Description
SINn	USART	USART n serial data input pin
SINn_R	USART	Relocated USART n serial data input pin
SOTn	USART	USART n serial data output pin
SOTn_R	USART	Relocated USART n serial data output pin
TINn	Reload Timer	Reload Timer n event input pin
TINn_R	Reload Timer	Relocated Reload Timer n event input pin
TOTn	Reload Timer	Reload Timer n output pin
TOTn_R	Reload Timer	Relocated Reload Timer n output pin
TTGn	PPG	Programmable Pulse Generator n trigger input pin
TXn	CAN	CAN interface n TX output pin
Vn	LCD	LCD voltage reference pin
Vcc	Supply	Power supply pin
Vss	Supply	Power supply pin
WOT	RTC	Real Time clock output pin
WOT_R	RTC	Relocated Real Time clock output pin
X0	Clock	Oscillator input pin
X0A	Clock	Subclock Oscillator input pin
X1	Clock	Oscillator output pin
X1A	Clock	Subclock Oscillator output pin
ZINn	QPRC	Quadrature Position/Revolution Counter Unit n input pin

#### 4. Pin Circuit Type

Pin No.	I/O Circuit Type*	Pin Name
1	Supply	Vss
2	F	C
3	P	P03_7 / INT1 / SIN1 / SEG40
4	J	P13_0 / INT2 / SOT1 / SEG41
5	P	P13_1 / INT3 / SCK1 / SEG42
6	J	P13_2 / PPG0 / TIN0 / FRCK1 / SEG43
7	J	P13_3 / PPG1 / TOT0 / WOT / SEG44
8	P	P13_4 / SIN0 / INT6 / SEG45
9	H	P13_5 / SOT0 / ADTG / INT7
10	M	P13_6 / SCK0 / CKOTX0
11	H	P13_7 / PPG2 / CKOT0
12	N	P04_4 / PPG3 / SDA0
13	N	P04_5 / PPG4 / SCL0
14	I	P06_0 / AN0 / IN2_R / SCK5
15	K	P06_1 / AN1 / IN3_R / SOT5
16	I	P06_2 / AN2 / INT5 / SIN5
17	K	P06_3 / AN3 / FRCK0
18	K	P06_4 / AN4 / IN0 / TTG0 / TTG4
19	K	P06_5 / AN5 / IN1 / TTG1 / TTG5
20	K	P06_6 / AN6 / TIN1 / IN4_R
21	K	P06_7 / AN7 / TOT1 / IN5_R
22	Supply	AVcc
23	G	AVRH
24	G	AVRL
25	Supply	AVss
26	K	P05_0 / AN8
27	K	P05_1 / AN9
28	K	P05_2 / AN10 / OUT2 / SGO1
29	K	P05_3 / AN11 / OUT3 / SGA1
30	Supply	Vcc
31	Supply	Vss
32	K	P05_4 / AN12 / INT2_R / WOT_R
33	K	P05_5 / AN13
34	K	P05_6 / AN14 / TIN2 / SGO1_R
35	K	P05_7 / AN15 / TOT2 / SGA1_R
36	V	P08_0 / AN16
37	V	P08_1 / AN17

Pin No.	I/O Circuit Type*	Pin Name
Pin No.	I/O Circuit Type*	Pin Name
38	V	P08_2 / AN18
39	V	P08_3 / AN19
40	V	P08_4 / AN20
41	H	P17_1 / PPG12_R
42	H	P17_2 / PPG13_R
43	V	P08_5 / AN21
44	V	P08_6 / AN22 / PPG6_B
45	V	P08_7 / AN23 / PPG7_B
46	V	P09_0 / AN24
47	V	P09_1 / AN25
48	V	P09_2 / AN26
49	V	P09_3 / AN27
50	Y	P09_4 / PPG12
51	Y	P09_5 / PPG13
52	Y	P09_6 / PPG14
53	Supply	Vcc
54	Supply	Vss
55	Y	P09_7 / PPG15
56	W	P10_0 / SIN2 / TIN3 / INT11 / AN28
57	V	P10_1 / SOT2 / TOT3 / AN29
58	W	P10_2 / SCK2 / PPG6 / AN30
59	V	P10_3 / PPG7 / AN31
60	Supply	Vcc
61	Supply	Vss
62	O	DEBUG I/F
63	H	P17_0
64	C	MD
65	A	X0
66	A	X1
67	Supply	Vss
68	B	P04_0 / X0A
69	B	P04_1 / X1A
70	C	RSTX
71	J	P11_0 / COM0
72	J	P11_1 / COM1 / PPG0_R
73	J	P11_2 / COM2 / PPG1_R
74	J	P11_3 / COM3 / PPG2_R
75	J	P11_4 / SEG0 / PPG3_R

Pin No.	I/O Circuit Type*	Pin Name
76	J	P11_5 / SEG1 / PPG4_R
Pin No.	I/O Circuit Type*	Pin Name
77	J	P11_6 / SEG2 / FRCK0_R / ZIN1
78	J	P11_7 / SEG3 / IN0_R / AIN1
79	J	P12_0 / SEG4 / IN1_R / BIN1
80	H	P12_1 / TIN1_R / PPG0_B
81	H	P12_2 / TOT1_R / PPG1_B
82	J	P12_3 / SEG7 / OUT2_R
83	J	P12_4 / SEG8 / OUT3_R
84	J	P12_5 / SEG9 / TIN2_R / PPG2_B
85	J	P12_6 / SEG10 / TOT2_R / PPG3_B
86	J	P12_7 / SEG11 / INT1_R
87	J	P00_0 / SEG12 / INT3_R
88	J	P00_1 / SEG13 / INT4_R
89	J	P00_2 / SEG14 / INT5_R
90	Supply	Vcc
91	Supply	Vss
92	J	P00_3 / SEG15 / INT6_R
93	J	P00_4 / SEG16 / INT7_R
94	J	P00_5 / SEG17 / IN6 / TTG2 / TTG6
95	J	P00_6 / SEG18 / IN7 / TTG3 / TTG7
96	J	P00_7 / SEG19 / SGO0 / INT14
97	J	P01_0 / SEG20 / SGA0
98	J	P01_1 / SEG21 / CKOT1 / OUT0
99	J	P01_2 / SEG22 / CKOTX1 / OUT1 / INT15
100	J	P01_3 / SEG23 / PPG5
101	P	P01_4 / SEG24 / SIN4 / INT8
102	J	P01_5 / SEG25 / SOT4
103	P	P01_6 / SEG26 / SCK4 / TTG12
104	J	P01_7 / SEG27 / CKOTX1_R / INT9 / TTG13 / ZIN0
105	J	P02_0 / SEG28 / CKOT1_R / INT10 / TTG14 / AIN0
106	J	P02_1 / SEG29 / IN6_R / TTG15
107	J	P02_2 / SEG30 / IN7_R / CKOT0_R / INT12 / BIN0
108	J	P02_3 / SEG31 / SGO0_R / PPG12_B
109	J	P02_4 / SEG32 / SGA0_R / PPG13_B
110	P	P02_5 / SEG33 / OUT0_R / INT13 / SIN5_R
111	J	P02_6 / SEG34 / OUT1_R
112	J	P02_7 / SEG35 / PPG5_R
113	L	P03_0 / V0 / SEG36 / PPG4_B

Pin No.	I/O Circuit Type*	Pin Name
114	L	P03_1 / V1 / SEG37 / PPG5_B
115	L	P03_2 / V2 / SEG38 / PPG14_B / SOT5_R
Pin No.	I/O Circuit Type*	Pin Name
116	Q	P03_3 / V3 / SEG39 / PPG15_B / SCK5_R
117	M	P03_4 / RX0 / INT4
118	H	P03_5 / TX0
119	H	P03_6 / INT0 / NMI
120	Supply	Vcc

\*: See "I/O Circuit Type" for details on the I/O circuit types.

### 5. I/O Circuit Type

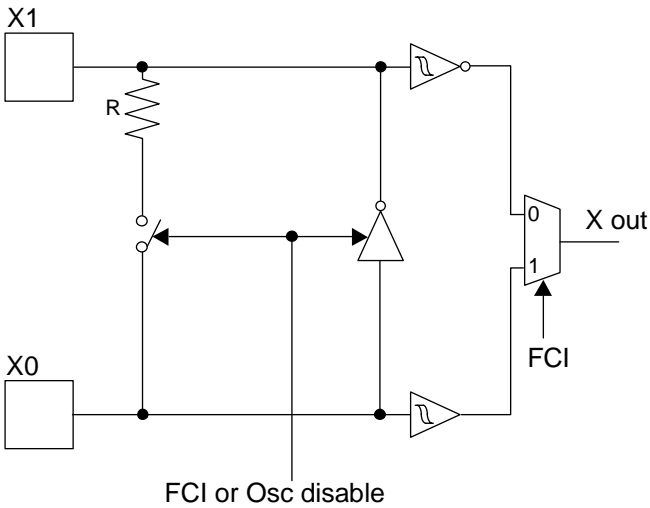
Type	Circuit	Remarks
A		<p>High-speed oscillation circuit:</p> <ul style="list-style-type: none"> <li>■ Programmable between oscillation mode (external crystal or resonator connected to X0/X1 pins) and Fast external Clock Input (FCI) mode (external clock connected to X0 pin)</li> <li>■ Feedback resistor = approx. 1.0MΩ</li> <li>■ The amplitude: 1.8V±0.15V to operate by the internal supply voltage</li> </ul>

Type	Circuit	Remarks
B	<p>The diagram for Type B shows a complex circuit. At the top, a pull-up resistor is connected to a 'Pull-up control' signal. Below it, two P-channel MOSFETs (P-ch) and one N-channel MOSFET (N-ch) are shown, with outputs labeled 'Pout' and 'Nout'. A 'Standby control for input shutdown' signal is connected to a resistor 'R' and an AND gate. The AND gate's output goes to an 'Automotive input' through an inverter. Below this, two input blocks 'X1A' and 'X0A' are shown. 'X1A' is connected to a resistor 'R' and an AND gate. The output of this AND gate goes to an inverter, which then connects to the '0' input of a multiplexer 'X out'. 'X0A' is connected to another AND gate, whose output goes to an inverter and then to the '1' input of 'X out'. A 'FCI or Osc disable' signal is connected to the 'FCI' input of the multiplexer. At the bottom, there is another set of P-ch, N-ch transistors and a pull-up resistor, similar to the top section, with an 'Automotive input' signal.</p>	<p>Low-speed oscillation circuit shared with GPIO functionality:</p> <ul style="list-style-type: none"> <li>■ Feedback resistor = approx. 5.0MΩ</li> <li>■ GPIO functionality selectable (CMOS level output (I<sub>OL</sub> = 4mA, I<sub>OH</sub> = -4mA), Automotive input with input shutdown function and programmable pull-up resistor)</li> </ul>
C	<p>The diagram for Type C shows a simple circuit where a resistor 'R' is connected to the input of a CMOS hysteresis input pin. The output of the hysteresis input is labeled 'Hysteresis inputs'.</p>	<p>CMOS hysteresis input pin</p>

Type	Circuit	Remarks
F		Power supply input protection circuit
G		<ul style="list-style-type: none"> <li>■ A/D converter ref+ (AVRH)/ ref- (AVRL) power supply input pin with protection circuit</li> <li>■ Without protection circuit against <math>V_{CC}</math> for pins AVRH/AVRL</li> </ul>
H		<ul style="list-style-type: none"> <li>■ CMOS level output (<math>I_{OL} = 4\text{mA}</math>, <math>I_{OH} = -4\text{mA}</math>)</li> <li>■ Automotive input with input shutdown function</li> <li>■ Programmable pull-up resistor</li> </ul>
I		<ul style="list-style-type: none"> <li>■ CMOS level output (<math>I_{OL} = 4\text{mA}</math>, <math>I_{OH} = -4\text{mA}</math>)</li> <li>■ CMOS hysteresis input with input shutdown function</li> <li>■ Programmable pull-up resistor</li> <li>■ Analog input</li> </ul>

Type	Circuit	Remarks
J		<ul style="list-style-type: none"> <li>■ CMOS level output (<math>I_{OL} = 4mA</math>, <math>I_{OH} = -4mA</math>)</li> <li>■ Automotive input with input shutdown function</li> <li>■ Programmable pull-up resistor</li> <li>■ SEG or COM output</li> </ul>
K		<ul style="list-style-type: none"> <li>■ CMOS level output (<math>I_{OL} = 4mA</math>, <math>I_{OH} = -4mA</math>)</li> <li>■ Automotive input with input shutdown function</li> <li>■ Programmable pull-up resistor</li> <li>■ Analog input</li> </ul>
L		<ul style="list-style-type: none"> <li>■ CMOS level output (<math>I_{OL} = 4mA</math>, <math>I_{OH} = -4mA</math>)</li> <li>■ Automotive input with input shutdown function</li> <li>■ Programmable pull-up resistor</li> <li>■ Vn input or SEG output</li> </ul>

Type	Circuit	Remarks
M		<ul style="list-style-type: none"> <li>■ CMOS level output (<math>I_{OL} = 4\text{mA}</math>, <math>I_{OH} = -4\text{mA}</math>)</li> <li>■ CMOS hysteresis input with input shutdown function</li> <li>■ Programmable pull-up resistor</li> </ul>
N		<ul style="list-style-type: none"> <li>■ CMOS level output (<math>I_{OL} = 3\text{mA}</math>, <math>I_{OH} = -3\text{mA}</math>)</li> <li>■ CMOS hysteresis input with input shutdown function</li> <li>■ Programmable pull-up resistor</li> </ul> <p>*: N-channel transistor has slew rate control according to I<sup>2</sup>C spec, irrespective of usage.</p>
O		<ul style="list-style-type: none"> <li>■ Open-drain I/O</li> <li>■ Output 25mA, <math>V_{CC} = 2.7\text{V}</math></li> <li>■ TTL input</li> </ul>

Type	Circuit	Remarks
P		<ul style="list-style-type: none"> <li>■ CMOS level output (<math>I_{OL} = 4\text{mA}</math>, <math>I_{OH} = -4\text{mA}</math>)</li> <li>■ CMOS hysteresis inputs with input shutdown function</li> <li>■ Programmable pull-up resistor</li> <li>■ SEG or COM output</li> </ul>
Q		<ul style="list-style-type: none"> <li>■ CMOS level output (<math>I_{OL} = 4\text{mA}</math>, <math>I_{OH} = -4\text{mA}</math>)</li> <li>■ CMOS hysteresis inputs with input shutdown function</li> <li>■ Programmable pull-up resistor</li> <li>■ Vn input or SEG output</li> </ul>
V		<ul style="list-style-type: none"> <li>■ CMOS level output (programmable <math>I_{OL} = 4\text{mA}</math>, <math>I_{OH} = -4\text{mA}</math> and <math>I_{OL} = 20\text{mA}</math>, <math>I_{OH} = -20\text{mA}</math>)</li> <li>■ Automotive input with input shutdown function</li> <li>■ Programmable pull-up resistor</li> <li>■ Analog input</li> </ul>

Type	Circuit	Remarks
W		<ul style="list-style-type: none"> <li>■ CMOS level output (programmable <math>I_{OL} = 4\text{mA}</math>, <math>I_{OH} = -4\text{mA}</math> and <math>I_{OL} = 20\text{mA}</math>, <math>I_{OH} = -20\text{mA}</math>)</li> <li>■ CMOS hysteresis input with input shutdown function</li> <li>■ Programmable pull-up resistor</li> <li>■ Analog input</li> </ul>
Y		<ul style="list-style-type: none"> <li>■ CMOS level output (programmable <math>I_{OL} = 4\text{mA}</math>, <math>I_{OH} = -4\text{mA}</math> and <math>I_{OL} = 20\text{mA}</math>, <math>I_{OH} = -20\text{mA}</math>)</li> <li>■ Automotive input with input shutdown function</li> <li>■ Programmable pull-up resistor</li> </ul>

## 6. Memory Map

FF:FFFF <sub>H</sub>	USER ROM*1
DE:0000 <sub>H</sub> DD:FFFF <sub>H</sub>	Reserved
10:0000 <sub>H</sub>	
0F:C000 <sub>H</sub>	Boot-ROM
0E:9000 <sub>H</sub>	Peripheral
	Reserved
01:0000 <sub>H</sub>	
00:8000 <sub>H</sub>	ROM/RAM MIRROR
RAMSTART0*2	Internal RAM bank0
	Reserved
00:0C00 <sub>H</sub>	
00:0380 <sub>H</sub>	Peripheral
00:0180 <sub>H</sub>	GPR*3
00:0100 <sub>H</sub>	DMA
00:00F0 <sub>H</sub>	Reserved
00:0000 <sub>H</sub>	Peripheral

\*1: For details about USER ROM area, see “User ROM Memory Map for Flash Devices” on the following pages.  
 \*2: For RAMSTART addresses, see the table on the next page.  
 \*3: Unused GPR banks can be used as RAM area.  
 GPR: General-Purpose Register  
 The DMA area is only available if the device contains the corresponding resource.  
 The available RAM and ROM area depends on the device.

## 7. RAMSTART Addresses

Devices	Bank 0 RAM Size	RAMSTART0
CY96F6C5	8KB	00:6200 <sub>H</sub>
CY96F6C6	16KB	00:4200 <sub>H</sub>

### 8. User ROM Memory Map for Flash Devices

CPU mode address	Flash memory mode address	CY96F6C5	CY96F6C6		
		Flash size 128.5KB + 32KB	Flash size 256.5KB + 32KB		
FF:FFFF <sub>H</sub> FF:0000 <sub>H</sub>	3F:FFFF <sub>H</sub> 3F:0000 <sub>H</sub>	SA39 - 64KB	SA39 - 64KB	Bank A of Flash A	
FE:FFFF <sub>H</sub> FE:0000 <sub>H</sub>	3E:FFFF <sub>H</sub> 3E:0000 <sub>H</sub>	SA38 - 64KB	SA38 - 64KB		
FD:FFFF <sub>H</sub> FD:0000 <sub>H</sub>	3D:FFFF <sub>H</sub> 3D:0000 <sub>H</sub>	Reserved	SA37 - 64KB		
FC:FFFF <sub>H</sub> FC:0000 <sub>H</sub>	3C:FFFF <sub>H</sub> 3C:0000 <sub>H</sub>		SA36 - 64KB		
FB:FFFF <sub>H</sub>			Reserved		
DF:A000					Bank B of Flash A
DF:9FFF <sub>H</sub> DF:8000 <sub>H</sub>	1F:9FFF <sub>H</sub> 1F:8000 <sub>H</sub>	SA4 - 8KB	SA4 - 8KB		
DF:7FFF <sub>H</sub> DF:6000 <sub>H</sub>	1F:7FFF <sub>H</sub> 1F:6000 <sub>H</sub>	SA3 - 8KB	SA3 - 8KB		
DF:5FFF <sub>H</sub> DF:4000 <sub>H</sub>	1F:5FFF <sub>H</sub> 1F:4000 <sub>H</sub>	SA2 - 8KB	SA2 - 8KB		
DF:3FFF <sub>H</sub> DF:2000 <sub>H</sub>	1F:3FFF <sub>H</sub> 1F:2000 <sub>H</sub>	SA1 - 8KB	SA1 - 8KB		
DF:1FFF <sub>H</sub> DF:0000 <sub>H</sub>	1F:1FFF <sub>H</sub> 1F:0000 <sub>H</sub>	SAS - 512B*	SAS - 512B*	Bank A of Flash A	
DE:FFFF <sub>H</sub> DE:0000 <sub>H</sub>		Reserved	Reserved		

\*: Physical address area of SAS-512B is from DF:0000<sub>H</sub> to DF:01FF<sub>H</sub>.  
 Others (from DF:0200<sub>H</sub> to DF:1FFF<sub>H</sub>) is mirror area of SAS-512B.  
 Sector SAS contains the ROM configuration block RCBA at CPU address DF:0000<sub>H</sub> -DF:01FF<sub>H</sub>.  
 SAS cannot be used for E<sup>2</sup>PROM emulation.

## 9. Serial Programming Communication Interface

USART pins for Flash serial programming (MD = 0, DEBUG I/F = 0, Serial Communication mode)

CY966C0		
Pin Number	USART Number	Normal Function
8	USART0	SIN0
9		SOT0
10		SCK0
3	USART1	SIN1
4		SOT1
5		SCK1
56	USART2	SIN2
57		SOT2
58		SCK2
101	USART4	SIN4
102		SOT4
103		SCK4

## 10. Interrupt Vector Table

Vector Number	Offset in Vector Table	Vector Name	Cleared by DMA	Index in ICR to Program	Description
0	3FC <sub>H</sub>	CALLV0	No	-	CALLV instruction
1	3F8 <sub>H</sub>	CALLV1	No	-	CALLV instruction
2	3F4 <sub>H</sub>	CALLV2	No	-	CALLV instruction
3	3F0 <sub>H</sub>	CALLV3	No	-	CALLV instruction
4	3EC <sub>H</sub>	CALLV4	No	-	CALLV instruction
5	3E8 <sub>H</sub>	CALLV5	No	-	CALLV instruction
6	3E4 <sub>H</sub>	CALLV6	No	-	CALLV instruction
7	3E0 <sub>H</sub>	CALLV7	No	-	CALLV instruction
8	3DC <sub>H</sub>	RESET	No	-	Reset vector
9	3D8 <sub>H</sub>	INT9	No	-	INT9 instruction
10	3D4 <sub>H</sub>	EXCEPTION	No	-	Undefined instruction execution
11	3D0 <sub>H</sub>	NMI	No	-	Non-Maskable Interrupt
12	3CC <sub>H</sub>	DLY	No	12	Delayed Interrupt
13	3C8 <sub>H</sub>	RC_TIMER	No	13	RC Clock Timer
14	3C4 <sub>H</sub>	MC_TIMER	No	14	Main Clock Timer
15	3C0 <sub>H</sub>	SC_TIMER	No	15	Sub Clock Timer
16	3BC <sub>H</sub>	LVDI	No	16	Low Voltage Detector
17	3B8 <sub>H</sub>	EXTINT0	Yes	17	External Interrupt 0
18	3B4 <sub>H</sub>	EXTINT1	Yes	18	External Interrupt 1
19	3B0 <sub>H</sub>	EXTINT2	Yes	19	External Interrupt 2
20	3AC <sub>H</sub>	EXTINT3	Yes	20	External Interrupt 3
21	3A8 <sub>H</sub>	EXTINT4	Yes	21	External Interrupt 4
22	3A4 <sub>H</sub>	EXTINT5	Yes	22	External Interrupt 5
23	3A0 <sub>H</sub>	EXTINT6	Yes	23	External Interrupt 6
24	39C <sub>H</sub>	EXTINT7	Yes	24	External Interrupt 7
25	398 <sub>H</sub>	EXTINT8	Yes	25	External Interrupt 8
26	394 <sub>H</sub>	EXTINT9	Yes	26	External Interrupt 9
27	390 <sub>H</sub>	EXTINT10	Yes	27	External Interrupt 10
28	38C <sub>H</sub>	EXTINT11	Yes	28	External Interrupt 11
29	388 <sub>H</sub>	EXTINT12	Yes	29	External Interrupt 12
30	384 <sub>H</sub>	EXTINT13	Yes	30	External Interrupt 13
31	380 <sub>H</sub>	EXTINT14	Yes	31	External Interrupt 14
32	37C <sub>H</sub>	EXTINT15	Yes	32	External Interrupt 15
33	378 <sub>H</sub>	CAN0	No	33	CAN Controller 0
34	374 <sub>H</sub>	-	-	34	Reserved
35	370 <sub>H</sub>	-	-	35	Reserved
36	36C <sub>H</sub>	-	-	36	Reserved
37	368 <sub>H</sub>	-	-	37	Reserved
38	364 <sub>H</sub>	PPG0	Yes	38	Programmable Pulse Generator 0
39	360 <sub>H</sub>	PPG1	Yes	39	Programmable Pulse Generator 1

Vector Number	Offset in Vector Table	Vector Name	Cleared by DMA	Index in ICR to Program	Description
40	35C <sub>H</sub>	PPG2	Yes	40	Programmable Pulse Generator 2
41	358 <sub>H</sub>	PPG3	Yes	41	Programmable Pulse Generator 3
42	354 <sub>H</sub>	PPG4	Yes	42	Programmable Pulse Generator 4
43	350 <sub>H</sub>	PPG5	Yes	43	Programmable Pulse Generator 5
44	34C <sub>H</sub>	PPG6	Yes	44	Programmable Pulse Generator 6
45	348 <sub>H</sub>	PPG7	Yes	45	Programmable Pulse Generator 7
46	344 <sub>H</sub>	-	-	46	Reserved
47	340 <sub>H</sub>	-	-	47	Reserved
48	33C <sub>H</sub>	-	-	48	Reserved
49	338 <sub>H</sub>	-	-	49	Reserved
50	334 <sub>H</sub>	PPG12	Yes	50	Programmable Pulse Generator 12
51	330 <sub>H</sub>	PPG13	Yes	51	Programmable Pulse Generator 13
52	32C <sub>H</sub>	PPG14	Yes	52	Programmable Pulse Generator 14
53	328 <sub>H</sub>	PPG15	Yes	53	Programmable Pulse Generator 15
54	324 <sub>H</sub>	-	-	54	Reserved
55	320 <sub>H</sub>	-	-	55	Reserved
56	31C <sub>H</sub>	-	-	56	Reserved
57	318 <sub>H</sub>	-	-	57	Reserved
58	314 <sub>H</sub>	RLT0	Yes	58	Reload Timer 0
59	310 <sub>H</sub>	RLT1	Yes	59	Reload Timer 1
60	30C <sub>H</sub>	RLT2	Yes	60	Reload Timer 2
61	308 <sub>H</sub>	RLT3	Yes	61	Reload Timer 3
62	304 <sub>H</sub>	-	-	62	Reserved
63	300 <sub>H</sub>	-	-	63	Reserved
64	2FC <sub>H</sub>	RLT6	Yes	64	Reload Timer 6
65	2F8 <sub>H</sub>	ICU0	Yes	65	Input Capture Unit 0
66	2F4 <sub>H</sub>	ICU1	Yes	66	Input Capture Unit 1
67	2F0 <sub>H</sub>	ICU2	Yes	67	Input Capture Unit 2
68	2EC <sub>H</sub>	ICU3	Yes	68	Input Capture Unit 3
69	2E8 <sub>H</sub>	ICU4	Yes	69	Input Capture Unit 4
70	2E4 <sub>H</sub>	ICU5	Yes	70	Input Capture Unit 5
71	2E0 <sub>H</sub>	ICU6	Yes	71	Input Capture Unit 6
72	2DC <sub>H</sub>	ICU7	Yes	72	Input Capture Unit 7
73	2D8 <sub>H</sub>	-	-	73	Reserved
74	2D4 <sub>H</sub>	-	-	74	Reserved
75	2D0 <sub>H</sub>	-	-	75	Reserved
76	2CC <sub>H</sub>	-	-	76	Reserved
77	2C8 <sub>H</sub>	OCU0	Yes	77	Output Compare Unit 0
78	2C4 <sub>H</sub>	OCU1	Yes	78	Output Compare Unit 1
79	2C0 <sub>H</sub>	OCU2	Yes	79	Output Compare Unit 2
80	2BC <sub>H</sub>	OCU3	Yes	80	Output Compare Unit 3

Vector Number	Offset in Vector Table	Vector Name	Cleared by DMA	Index in ICR to Program	Description
81	2B8 <sub>H</sub>	-	-	81	Reserved
82	2B4 <sub>H</sub>	-	-	82	Reserved
83	2B0 <sub>H</sub>	-	-	83	Reserved
84	2AC <sub>H</sub>	-	-	84	Reserved
85	2A8 <sub>H</sub>	-	-	85	Reserved
86	2A4 <sub>H</sub>	-	-	86	Reserved
87	2A0 <sub>H</sub>	-	-	87	Reserved
88	29C <sub>H</sub>	-	-	88	Reserved
89	298 <sub>H</sub>	FRT0	Yes	89	Free-Running Timer 0
90	294 <sub>H</sub>	FRT1	Yes	90	Free-Running Timer 1
91	290 <sub>H</sub>	-	-	91	Reserved
92	28C <sub>H</sub>	-	-	92	Reserved
93	288 <sub>H</sub>	RTC0	No	93	Real Time Clock
94	284 <sub>H</sub>	CAL0	No	94	Clock Calibration Unit
95	280 <sub>H</sub>	SG0	No	95	Sound Generator 0
96	27C <sub>H</sub>	IIC0	Yes	96	I <sup>2</sup> C interface 0
97	278 <sub>H</sub>	-	-	97	Reserved
98	274 <sub>H</sub>	ADC0	Yes	98	A/D Converter 0
99	270 <sub>H</sub>	-	-	99	Reserved
100	26C <sub>H</sub>	-	-	100	Reserved
101	268 <sub>H</sub>	LINR0	Yes	101	LIN USART 0 RX
102	264 <sub>H</sub>	LINT0	Yes	102	LIN USART 0 TX
103	260 <sub>H</sub>	LINR1	Yes	103	LIN USART 1 RX
104	25C <sub>H</sub>	LINT1	Yes	104	LIN USART 1 TX
105	258 <sub>H</sub>	LINR2	Yes	105	LIN USART 2 RX
106	254 <sub>H</sub>	LINT2	Yes	106	LIN USART 2 TX
107	250 <sub>H</sub>	-	-	107	Reserved
108	24C <sub>H</sub>	-	-	108	Reserved
109	248 <sub>H</sub>	LINR4	Yes	109	LIN USART 4 RX
110	244 <sub>H</sub>	LINT4	Yes	110	LIN USART 4 TX
111	240 <sub>H</sub>	LINR5	Yes	111	LIN USART 5 RX
112	23C <sub>H</sub>	LINT5	Yes	112	LIN USART 5 TX
113	238 <sub>H</sub>	-	-	113	Reserved
114	234 <sub>H</sub>	-	-	114	Reserved
115	230 <sub>H</sub>	-	-	115	Reserved
116	22C <sub>H</sub>	-	-	116	Reserved
117	228 <sub>H</sub>	-	-	117	Reserved
118	224 <sub>H</sub>	-	-	118	Reserved
119	220 <sub>H</sub>	-	-	119	Reserved
120	21C <sub>H</sub>	-	-	120	Reserved

Vector Number	Offset in Vector Table	Vector Name	Cleared by DMA	Index in ICR to Program	Description
121	218 <sub>H</sub>	SG1	No	121	Sound Generator 1
122	214 <sub>H</sub>	-	-	122	Reserved
123	210 <sub>H</sub>	-	-	123	Reserved
124	20C <sub>H</sub>	-	-	124	Reserved
125	208 <sub>H</sub>	-	-	125	Reserved
126	204 <sub>H</sub>	-	-	126	Reserved
127	200 <sub>H</sub>	-	-	127	Reserved
128	1FC <sub>H</sub>	-	-	128	Reserved
129	1F8 <sub>H</sub>	-	-	129	Reserved
130	1F4 <sub>H</sub>	-	-	130	Reserved
131	1F0 <sub>H</sub>	-	-	131	Reserved
132	1EC <sub>H</sub>	-	-	132	Reserved
133	1E8 <sub>H</sub>	FLASHA	Yes	133	Flash memory A interrupt
134	1E4 <sub>H</sub>	-	-	134	Reserved
135	1E0 <sub>H</sub>	-	-	135	Reserved
136	1DC <sub>H</sub>	-	-	136	Reserved
137	1D8 <sub>H</sub>	QPRC0	Yes	137	Quad Position/Revolution counter 0
138	1D4 <sub>H</sub>	QPRC1	Yes	138	Quad Position/Revolution counter 1
139	1D0 <sub>H</sub>	ADCRC0	No	139	A/D Converter 0 - Range Comparator
140	1CC <sub>H</sub>	ADCPD0	No	140	A/D Converter 0 - Pulse detection
141	1C8 <sub>H</sub>	-	-	141	Reserved
142	1C4 <sub>H</sub>	-	-	142	Reserved
143	1C0 <sub>H</sub>	-	-	143	Reserved

## 11. Handling Precautions

Any semiconductor devices have inherently a certain rate of failure. The possibility of failure is greatly affected by the conditions in which they are used (circuit conditions, environmental conditions, etc.). This page describes precautions that must be observed to minimize the chance of failure and to obtain higher reliability from your Cypress semiconductor devices.

### 11.1 Precautions for Product Design

This section describes precautions when designing electronic equipment using semiconductor devices.

#### ■ Absolute Maximum Ratings

Semiconductor devices can be permanently damaged by application of stress (voltage, current, temperature, etc.) in excess of certain established limits, called absolute maximum ratings. Do not exceed these ratings.

#### ■ Recommended Operating Conditions

Recommended operating conditions are normal operating ranges for the semiconductor device. All the device's electrical characteristics are warranted when operated within these ranges.

Always use semiconductor devices within the recommended operating conditions. Operation outside these ranges may adversely affect reliability and could result in device failure.

No warranty is made with respect to uses, operating conditions, or combinations not represented on the data sheet. Users considering application outside the listed conditions are advised to contact their sales representative beforehand.

#### ■ Processing and Protection of Pins

These precautions must be followed when handling the pins which connect semiconductor devices to power supply and input/output functions.

##### (1) Preventing Over-Voltage and Over-Current Conditions

Exposure to voltage or current levels in excess of maximum ratings at any pin is likely to cause deterioration within the device, and in extreme cases leads to permanent damage of the device. Try to prevent such overvoltage or over-current conditions at the design stage.

##### (2) Protection of Output Pins

Shorting of output pins to supply pins or other output pins, or connection to large capacitance can cause large current flows. Such conditions if present for extended periods of time can damage the device.

Therefore, avoid this type of connection.

##### (3) Handling of Unused Input Pins

Unconnected input pins with very high impedance levels can adversely affect stability of operation. Such pins should be connected through an appropriate resistance to a power supply pin or ground pin.

#### ■ Latch-up

Semiconductor devices are constructed by the formation of P-type and N-type areas on a substrate. When subjected to abnormally high voltages, internal parasitic PNP junctions (called thyristor structures) may be formed, causing large current levels in excess of several hundred mA to flow continuously at the power supply pin. This condition is called latch-up.

**CAUTION:** The occurrence of latch-up not only causes loss of reliability in the semiconductor device, but can cause injury or damage from high heat, smoke or flame. To prevent this from happening, do the following:

(1) Be sure that voltages applied to pins do not exceed the absolute maximum ratings. This should include attention to abnormal noise, surge levels, etc.

(2) Be sure that abnormal current flows do not occur during the power-on sequence.

#### ■ Observance of Safety Regulations and Standards

Most countries in the world have established standards and regulations regarding safety, protection from electromagnetic interference, etc. Customers are requested to observe applicable regulations and standards in the design of products.

#### ■ Fail-Safe Design

Any semiconductor devices have inherently a certain rate of failure. You must protect against injury, damage or loss from such failures by incorporating safety design measures into your facility and equipment such as redundancy, fire protection, and prevention of over-current levels and other abnormal operating conditions.

#### ■ Precautions Related to Usage of Devices

Cypress semiconductor devices are intended for use in standard applications (computers, office automation and other office equipment, industrial, communications, and measurement equipment, personal or household devices, etc.).

**CAUTION:** Customers considering the use of our products in special applications where failure or abnormal operation may directly affect human lives or cause physical injury or property damage, or where extremely high levels of reliability are demanded (such as aerospace systems, atomic energy controls, sea floor repeaters, vehicle operating controls, medical devices for life support, etc.) are requested to consult with sales representatives before such use. The company will not be responsible for damages arising from such use without prior approval.

### 11.2 Precautions for Package Mounting

Package mounting may be either lead insertion type or surface mount type. In either case, for heat resistance during soldering, you should only mount under Cypress's recommended conditions. For detailed information about mount conditions, contact your sales representative.

#### ■ Lead Insertion Type

Mounting of lead insertion type packages onto printed circuit boards may be done by two methods: direct soldering on the board, or mounting by using a socket.

Direct mounting onto boards normally involves processes for inserting leads into through-holes on the board and using the flow soldering (wave soldering) method of applying liquid solder. In this case, the soldering process usually causes leads to be subjected to thermal stress in excess of the absolute ratings for storage temperature. Mounting processes should conform to Spansion recommended mounting conditions.

If socket mounting is used, differences in surface treatment of the socket contacts and IC lead surfaces can lead to contact deterioration after long periods. For this reason it is recommended that the surface treatment of socket contacts and IC leads be verified before mounting.

#### ■ Surface Mount Type

Surface mount packaging has longer and thinner leads than lead-insertion packaging, and therefore leads are more easily deformed or bent. The use of packages with higher pin counts and narrower pin pitch results in increased susceptibility to open connections caused by deformed pins, or shorting due to solder bridges.

You must use appropriate mounting techniques. Cypress recommends the solder reflow method, and has established a ranking of mounting conditions for each product. Users are advised to mount packages in accordance with Cypress ranking of recommended conditions.

#### ■ Lead-Free Packaging

**CAUTION:** When ball grid array (BGA) packages with Sn-Ag-Cu balls are mounted using Sn-Pb eutectic soldering, junction strength may be reduced under some conditions of use.

#### ■ Storage of Semiconductor Devices

Because plastic chip packages are formed from plastic resins, exposure to natural environmental conditions will cause absorption of moisture. During mounting, the application of heat to a package that has absorbed moisture can cause surfaces to peel, reducing moisture resistance and causing packages to crack. To prevent, do the following:

- (1) Avoid exposure to rapid temperature changes, which cause moisture to condense inside the product. Store products in locations where temperature changes are slight.
- (2) Use dry boxes for product storage. Products should be stored below 70% relative humidity, and at temperatures between 5°C and 30°C.  
When you open Dry Package that recommends humidity 40% to 70% relative humidity.
- (3) When necessary, Cypress packages semiconductor devices in highly moisture-resistant aluminum laminate bags, with a silica gel desiccant. Devices should be sealed in their aluminum laminate bags for storage.
- (4) Avoid storing packages where they are exposed to corrosive gases or high levels of dust.

#### ■ Baking

Packages that have absorbed moisture may be de-moisturized by baking (heat drying). Follow the Cypress recommended conditions for baking.

Condition: 125°C/24 h

**■ Static Electricity**

Because semiconductor devices are particularly susceptible to damage by static electricity, you must take the following precautions:

- (1) Maintain relative humidity in the working environment between 40% and 70%. Use of an apparatus for ion generation may be needed to remove electricity.
- (2) Electrically ground all conveyors, solder vessels, soldering irons and peripheral equipment.
- (3) Eliminate static body electricity by the use of rings or bracelets connected to ground through high resistance (on the level of 1 MΩ).  
Wearing of conductive clothing and shoes, use of conductive floor mats and other measures to minimize shock loads is recommended.
- (4) Ground all fixtures and instruments, or protect with anti-static measures.
- (5) Avoid the use of styrofoam or other highly static-prone materials for storage of completed board assemblies.

**11.3 Precautions for Use Environment**

Reliability of semiconductor devices depends on ambient temperature and other conditions as described above.

For reliable performance, do the following:

- (1) Humidity  
Prolonged use in high humidity can lead to leakage in devices as well as printed circuit boards. If high humidity levels are anticipated, consider anti-humidity processing.
- (2) Discharge of Static Electricity  
When high-voltage charges exist close to semiconductor devices, discharges can cause abnormal operation. In such cases, use anti-static measures or processing to prevent discharges.
- (3) Corrosive Gases, Dust, or Oil  
Exposure to corrosive gases or contact with dust or oil may lead to chemical reactions that will adversely affect the device. If you use devices in such conditions, consider ways to prevent such exposure or to protect the devices.
- (4) Radiation, Including Cosmic Radiation  
Most devices are not designed for environments involving exposure to radiation or cosmic radiation. Users should provide shielding as appropriate.
- (5) Smoke, Flame  
**CAUTION:** Plastic molded devices are flammable, and therefore should not be used near combustible substances. If devices begin to smoke or burn, there is danger of the release of toxic gases.

Customers considering the use of Cypress products in other special environmental conditions should consult with sales representatives.

## 12. Handling Devices

### Special Care is Required for the following when Handling the Device:

- Latch-up prevention
- Unused pins handling
- External clock usage
- Notes on PLL clock mode operation
- Power supply pins (V<sub>CC</sub>/V<sub>SS</sub>)
- Crystal oscillator and ceramic resonator circuit
- Turn on sequence of power supply to A/D converter and analog inputs
- Pin handling when not using the A/D converter
- Notes on Power-on
- Stabilization of power supply voltage
- Serial communication
- Mode Pin (MD)

#### 1. Latch-Up Prevention

CMOS IC chips may suffer latch-up under the following conditions:

- A voltage higher than V<sub>CC</sub> or lower than V<sub>SS</sub> is applied to an input or output pin.
- A voltage higher than the rated voltage is applied between V<sub>CC</sub> pins and V<sub>SS</sub> pins.
- The AV<sub>CC</sub> power supply is applied before the V<sub>CC</sub> voltage.

Latch-up may increase the power supply current dramatically, causing thermal damages to the device.

For the same reason, extra care is required to not let the analog power-supply voltage (AV<sub>CC</sub>, AVRH) exceed the digital power-supply voltage.

#### 2. Unused Pins Handling

Unused input pins can be left open when the input is disabled (corresponding bit of Port Input Enable register PIER = 0).

Leaving unused input pins open when the input is enabled may result in misbehavior and possible permanent damage of the device. To prevent latch-up, they must therefore be pulled up or pulled down through resistors which should be more than 2k $\Omega$ .

Unused bidirectional pins can be set either to the output state and be then left open, or to the input state with either input disabled or external pull-up/pull-down resistor as described above.

#### 3. External Clock Usage

The permitted frequency range of an external clock depends on the oscillator type and configuration.

See AC Characteristics for detailed modes and frequency limits. Single and opposite phase external clocks must be connected as follows:

**(1) Single Phase External Clock for Main Oscillator**

When using a single phase external clock for the Main oscillator, X0 pin must be driven and X1 pin left open.  
And supply 1.8V power to the external clock.

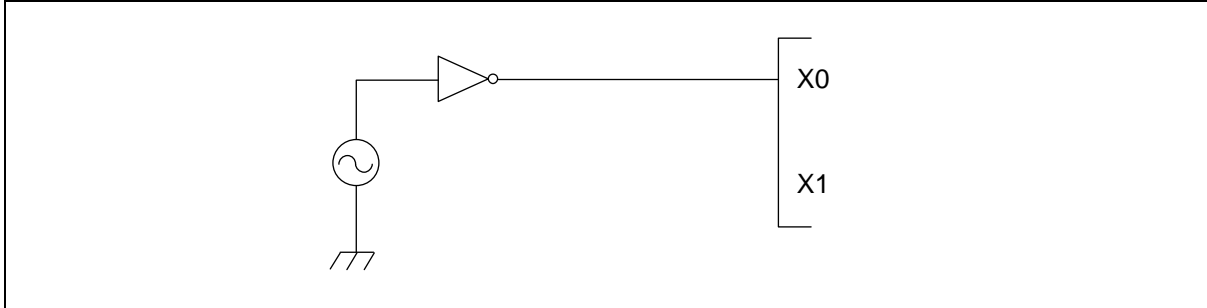

### (2) Single Phase External Clock for Sub Oscillator

When using a single phase external clock for the Sub oscillator, “External clock mode” must be selected and X0A/P04\_0 pin must be driven. X1A/P04\_1 pin can be configured as GPIO.

### (3) Opposite Phase External Clock

When using an opposite phase external clock, X1 (X1A) pins must be supplied with a clock signal which has the opposite phase to the X0 (X0A) pins. Supply level on X0 and X1 pins must be 1.8V.

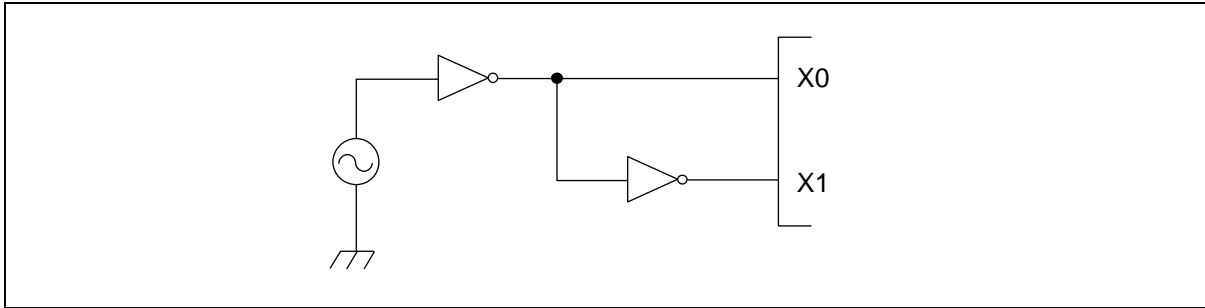

## 4. Notes on PLL Clock Mode Operation

If the microcontroller is operated with PLL clock mode and no external oscillator is operating or no external clock is supplied, the microcontroller attempts to work with the free oscillating PLL. Performance of this operation, however, cannot be guaranteed.

## 5. Power Supply Pins (V<sub>CC</sub>/V<sub>SS</sub>)

It is required that all V<sub>CC</sub>-level as well as all V<sub>SS</sub>-level power supply pins are at the same potential. If there is more than one V<sub>CC</sub> or V<sub>SS</sub> level, the device may operate incorrectly or be damaged even within the guaranteed operating range.

V<sub>CC</sub> and V<sub>SS</sub> pins must be connected to the device from the power supply with lowest possible impedance.

The smoothing capacitor at V<sub>CC</sub> pin must use the one of a capacity value that is larger than C<sub>s</sub>.

Besides this, as a measure against power supply noise, it is required to connect a bypass capacitor of about 0.1 μF between V<sub>CC</sub> and V<sub>SS</sub> pins as close as possible to V<sub>CC</sub> and V<sub>SS</sub> pins.

## 6. Crystal Oscillator and ceramic resonator Circuit

Noise at X0, X1 pins or X0A, X1A pins might cause abnormal operation. It is required to provide bypass capacitors with shortest possible distance to X0, X1 pins and X0A, X1A pins, crystal oscillator (or ceramic resonator) and ground lines, and, to the utmost effort, that the lines of oscillation circuit do not cross the lines of other circuits.

It is highly recommended to provide a printed circuit board art work surrounding X0, X1 pins and X0A, X1A pins with a ground area for stabilizing the operation.

It is highly recommended to evaluate the quartz/MCU or resonator/MCU system at the quartz or resonator manufacturer, especially when using low-Q resonators at higher frequencies.

## 7. Turn on Sequence of Power Supply to A/D Converter and Analog Inputs

It is required to turn the A/D converter power supply (AV<sub>CC</sub>, AVR<sub>H</sub>, AVR<sub>L</sub>) and analog inputs (AN<sub>n</sub>) on after turning the digital power supply (V<sub>CC</sub>) on.

It is also required to turn the digital power off after turning the A/D converter supply and analog inputs off. In this case, AVR<sub>H</sub> must not exceed AV<sub>CC</sub>. Input voltage for ports shared with analog input ports also must not exceed AV<sub>CC</sub> (turning the analog and digital power supplies simultaneously on or off is acceptable).

## 8. Pin Handling when not using the A/D Converter

If the A/D converter is not used, the power supply pins for A/D converter should be connected such as AV<sub>CC</sub> = V<sub>CC</sub>, AV<sub>SS</sub> = AVR<sub>H</sub> = AVR<sub>L</sub> = V<sub>SS</sub>.

**9. Notes on Power-on**

To prevent malfunction of the internal voltage regulator, supply voltage profile while turning the power supply on should be slower than 50 $\mu$ s from 0.2V to 2.7V.

**10. Stabilization of Power Supply Voltage**

If the power supply voltage varies acutely even within the operation safety range of the  $V_{CC}$  power supply voltage, a malfunction may occur. The  $V_{CC}$  power supply voltage must therefore be stabilized. As stabilization guidelines, the power supply voltage must be stabilized in such a way that  $V_{CC}$  ripple fluctuations (peak to peak value) in the commercial frequencies (50Hz to 60Hz) fall within 10% of the standard  $V_{CC}$  power supply voltage and the transient fluctuation rate becomes 0.1V/ $\mu$ s or less in instantaneous fluctuation for power supply switching.

**11. Serial Communication**

There is a possibility to receive wrong data due to noise or other causes on the serial communication.

Therefore, design a printed circuit board so as to avoid noise.

Consider receiving of wrong data when designing the system. For example apply a checksum and retransmit the data if an error occurs.

**12. Mode Pin (MD)**

Connect the mode pin directly to  $V_{CC}$  or  $V_{SS}$  pin. To prevent the device unintentionally entering test mode due to noise, lay out the printed circuit board so as to minimize the distance from the mode pin to  $V_{CC}$  or  $V_{SS}$  pin and provide a low-impedance connection.

## 13. Electrical Characteristics

### 13.1 Absolute Maximum Ratings

Parameter	Symbol	Condition	Rating		Unit	Remarks
			Min	Max		
Power supply voltage*1	V <sub>CC</sub>	-	V <sub>SS</sub> - 0.3	V <sub>SS</sub> + 6.0	V	
Analog power supply voltage*1	AV <sub>CC</sub>	-	V <sub>SS</sub> - 0.3	V <sub>SS</sub> + 6.0	V	V <sub>CC</sub> = AV <sub>CC</sub> *2
Analog reference voltage*1	AVRH, AVRL	-	V <sub>SS</sub> - 0.3	V <sub>SS</sub> + 6.0	V	AV <sub>CC</sub> ≥ AVRH, AV <sub>CC</sub> ≥ AVRL, AVRH > AVRL, AVRL ≥ AV <sub>SS</sub>
LCD power supply voltage*1	V0 to V3	-	V <sub>SS</sub> - 0.3	V <sub>SS</sub> + 6.0	V	V0 to V3 must not exceed V <sub>CC</sub>
Input voltage*1	V <sub>I</sub>	-	V <sub>SS</sub> - 0.3	V <sub>SS</sub> + 6.0	V	V <sub>I</sub> ≤ V <sub>CC</sub> + 0.3V*3
Output voltage*1	V <sub>O</sub>	-	V <sub>SS</sub> - 0.3	V <sub>SS</sub> + 6.0	V	V <sub>O</sub> ≤ V <sub>CC</sub> + 0.3V*3
Maximum Clamp Current	I <sub>CLAMP</sub>	-	-4.0	+4.0	mA	Applicable to general purpose I/O pins *4
Total Maximum Clamp Current	Σ I <sub>CLAMP</sub>	-	-	32	mA	Applicable to general purpose I/O pins *4
"L" level maximum output current	I <sub>OL</sub>	-	-	15	mA	Normal port
	I <sub>OLHCO</sub>	-	-	20	mA	High current port
"L" level average output current	I <sub>OLAV</sub>	-	-	4	mA	Normal port
	I <sub>OLAVHCO</sub>	-	-	15	mA	High current port
"L" level maximum overall output current	ΣI <sub>OL</sub>	-	-	80	mA	Normal port
	ΣI <sub>OLHCO</sub>	-	-	150	mA	High current port
"L" level average overall output current	ΣI <sub>OLAV</sub>	-	-	40	mA	Normal port
	ΣI <sub>OLAVHCO</sub>	-	-	100	mA	High current port
"H" level maximum output current	I <sub>OH</sub>	-	-	-15	mA	Normal port
	I <sub>OHCO</sub>	-	-	-20	mA	High current port
"H" level average output current	I <sub>OHAV</sub>	-	-	-4	mA	Normal port
	I <sub>OHAVHCO</sub>	-	-	-15	mA	High current port
"H" level maximum overall output current	ΣI <sub>OH</sub>	-	-	-80	mA	Normal port
	ΣI <sub>OHCO</sub>	-	-	-150	mA	High current port
"H" level average overall output current	ΣI <sub>OHAV</sub>	-	-	-40	mA	Normal port
	ΣI <sub>OHAVHCO</sub>	-	-	-100	mA	High current port
Power consumption*5	P <sub>D</sub>	T <sub>A</sub> = +125°C	-	446 <sup>6</sup>	mW	
Operating ambient temperature	T <sub>A</sub>	-	-40	+125 <sup>7</sup>	°C	
Storage temperature	T <sub>STG</sub>	-	-55	+150	°C	

\*1: This parameter is based on V<sub>SS</sub> = AV<sub>SS</sub> = 0V.

\*2: AV<sub>CC</sub> and V<sub>CC</sub> must be set to the same voltage. It is required that AV<sub>CC</sub> does not exceed V<sub>CC</sub> and that the voltage at the analog inputs does not exceed AV<sub>CC</sub> when the power is switched on.

\*3: V<sub>I</sub> and V<sub>O</sub> should not exceed V<sub>CC</sub> + 0.3V. V<sub>I</sub> should also not exceed the specified ratings. However if the maximum current to/from an input is limited by some means with external components, the I<sub>CLAMP</sub> rating supersedes the V<sub>I</sub> rating. Input/Output voltages of general I/O ports depend on V<sub>CC</sub>.

\*4: • Applicable to all general purpose I/O pins (Pnn\_m).  
• Use within recommended operating conditions.

- Use at DC voltage (current).
- The +B signal should always be applied a limiting resistance placed between the +B signal and the microcontroller.
- The value of the limiting resistance should be set so that when the +B signal is applied the input current to the microcontroller pin does not exceed rated values, either instantaneously or for prolonged periods.
- Note that when the microcontroller drive current is low, such as in the power saving modes, the +B input potential may pass through the protective diode and increase the potential at the  $V_{CC}$  pin, and this may affect other devices.
- Note that if a +B signal is input when the microcontroller power supply is off (not fixed at 0V), the power supply is provided from the pins, so that incomplete operation may result.
- Note that if the +B input is applied during power-on, the power supply is provided from the pins and the resulting supply voltage may not be sufficient to operate the Power reset.
- The DEBUG I/F pin has only a protective diode against  $V_{SS}$ . Hence it is only permitted to input a negative clamping current (4mA). For protection against positive input voltages, use an external clamping diode which limits the input voltage to maximum 6.0V.

• Sample recommended circuits:

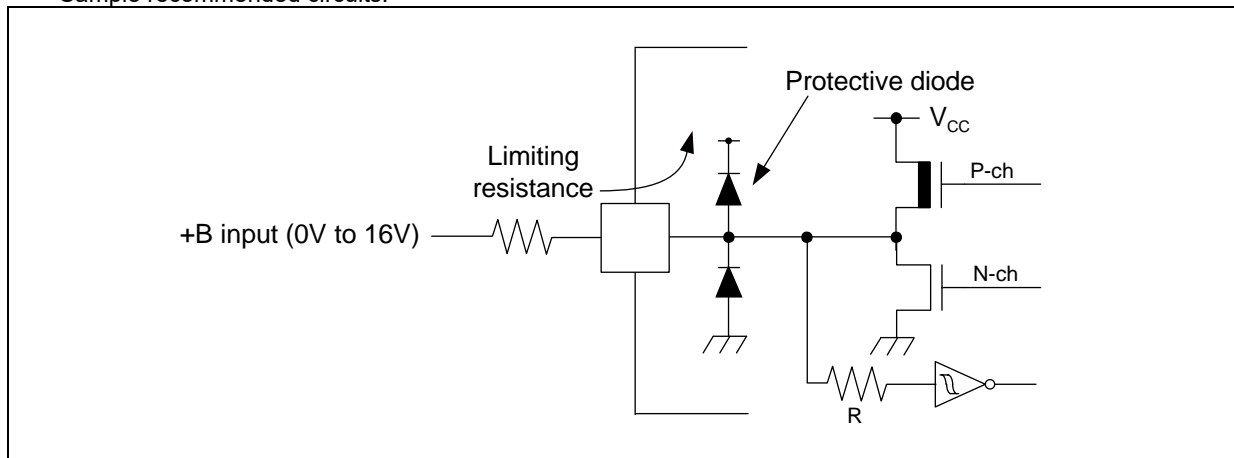

\*5: The maximum permitted power dissipation depends on the ambient temperature, the air flow velocity and the thermal conductance of the package on the PCB.

The actual power dissipation depends on the customer application and can be calculated as follows:

$$P_D = P_{IO} + P_{INT}$$

$$P_{IO} = \Sigma (V_{OL} \times I_{OL} + V_{OH} \times I_{OH}) \text{ (I/O load power dissipation, sum is performed on all I/O ports)}$$

$$P_{INT} = V_{CC} \times (I_{CC} + I_A) \text{ (internal power dissipation)}$$

$I_{CC}$  is the total core current consumption into  $V_{CC}$  as described in the “DC characteristics” and depends on the selected operation mode and clock frequency and the usage of functions like Flash programming.

$I_A$  is the analog current consumption into  $AV_{CC}$ .

\*6: Worst case value for a package mounted on single layer PCB at specified  $T_A$  without air flow.

\*7: Write/erase to a large sector in flash memory is warranted with  $T_A \leq + 105^\circ\text{C}$ .

**WARNING**

Semiconductor devices can be permanently damaged by application of stress (voltage, current, temperature, etc.) in excess of absolute maximum ratings. Do not exceed these ratings.

**13.2 Recommended Operating Conditions**

 ( $V_{SS} = AV_{SS} = 0V$ )

Parameter	Symbol	Value			Unit	Remarks
		Min	Typ	Max		
Power supply voltage	$V_{CC}, AV_{CC}$	2.7	-	5.5	V	
		2.0	-	5.5	V	Maintains RAM data in stop mode
Smoothing capacitor at C pin	$C_S$	0.5	1.0 to 3.9	4.7	$\mu F$	1.0 $\mu F$ (Allowance within $\pm 50\%$ ) 3.9 $\mu F$ (Allowance within $\pm 20\%$ ) Please use the ceramic capacitor or the capacitor of the frequency response of this level. The smoothing capacitor at $V_{CC}$ must use the one of a capacity value that is larger than $C_S$ .

**WARNING**

The recommended operating conditions are required in order to ensure the normal operation of the semiconductor device. All of the device's electrical characteristics are warranted when the device is operated within these ranges.

Always use semiconductor devices within their recommended operating condition ranges. Operation outside these ranges may adversely affect reliability and could result in device failure. No warranty is made with respect to uses, operating conditions, or combinations not represented on the data sheet. Users considering application outside the listed conditions are advised to contact their representatives beforehand.

13.3 DC Characteristics

13.3.1 Current Rating

( $V_{CC} = AV_{CC} = 2.7V$  to  $5.5V$ ,  $V_{SS} = AV_{SS} = 0V$ ,  $T_A = -40^{\circ}C$  to  $+125^{\circ}C$ )

Parameter	Symbol	Pin Name	Conditions	Value			Unit	Remarks
				Min	Typ	Max		
Power supply current in Run modes <sup>1</sup>	I <sub>CCPLL</sub>	V <sub>CC</sub>	PLL Run mode with CLKS1/2 = CLKB = CLKP1/2 = 32MHz	-	28	-	mA	T <sub>A</sub> = +25°C
			Flash 0 wait (CLKRC and CLKSC stopped)	-	-	38	mA	T <sub>A</sub> = +105°C
				-	-	39.5	mA	T <sub>A</sub> = +125°C
	I <sub>CCMAIN</sub>		Main Run mode with CLKS1/2 = CLKB = CLKP1/2 = 4MHz	-	3.5	-	mA	T <sub>A</sub> = +25°C
			Flash 0 wait (CLKPLL, CLKSC and CLKRC stopped)	-	-	8	mA	T <sub>A</sub> = +105°C
				-	-	9.5	mA	T <sub>A</sub> = +125°C
	I <sub>CCRCH</sub>		RC Run mode with CLKS1/2 = CLKB = CLKP1/2 = CLKRC = 2MHz	-	1.8	-	mA	T <sub>A</sub> = +25°C
			Flash 0 wait (CLKMC, CLKPLL and CLKSC stopped)	-	-	6	mA	T <sub>A</sub> = +105°C
				-	-	7.5	mA	T <sub>A</sub> = +125°C
	I <sub>CCRCL</sub>		RC Run mode with CLKS1/2 = CLKB = CLKP1/2 = CLKRC = 100kHz	-	0.16	-	mA	T <sub>A</sub> = +25°C
			Flash 0 wait (CLKMC, CLKPLL and CLKSC stopped)	-	-	3.5	mA	T <sub>A</sub> = +105°C
				-	-	5	mA	T <sub>A</sub> = +125°C
	I <sub>CCSUB</sub>		Sub Run mode with CLKS1/2 = CLKB = CLKP1/2 = 32kHz	-	0.1	-	mA	T <sub>A</sub> = +25°C
			Flash 0 wait (CLKMC, CLKPLL and CLKRC stopped)	-	-	3.3	mA	T <sub>A</sub> = +105°C
				-	-	4.8	mA	T <sub>A</sub> = +125°C

Parameter	Symbol	Pin Name	Conditions	Value			Unit	Remarks
				Min	Typ	Max		
Power supply current in Sleep modes <sup>*1</sup>	I <sub>CCSPLL</sub>	V <sub>CC</sub>	PLL Sleep mode with CLKS1/2 = CLKP1/2 = 32MHz (CLKRC and CLKSC stopped)	-	9.5	-	mA	T <sub>A</sub> = +25°C
				-	-	15	mA	T <sub>A</sub> = +105°C
				-	-	16.5	mA	T <sub>A</sub> = +125°C
	I <sub>CCSMAN</sub>		Main Sleep mode with CLKS1/2 = CLKP1/2 = 4MHz, SMCR:LPMSS = 0 (CLKPLL, CLKRC and CLKSC stopped)	-	1.1	-	mA	T <sub>A</sub> = +25°C
				-	-	4.7	mA	T <sub>A</sub> = +105°C
				-	-	6.2	mA	T <sub>A</sub> = +125°C
	I <sub>CCSRCH</sub>		RC Sleep mode with CLKS1/2 = CLKP1/2 = CLKRC = 2MHz, SMCR:LPMSS = 0 (CLKMC, CLKPLL and CLKSC stopped)	-	0.6	-	mA	T <sub>A</sub> = +25°C
				-	-	4.1	mA	T <sub>A</sub> = +105°C
				-	-	5.6	mA	T <sub>A</sub> = +125°C
	I <sub>CCSRCL</sub>		RC Sleep mode with CLKS1/2 = CLKP1/2 = CLKRC = 100kHz (CLKMC, CLKPLL and CLKSC stopped)	-	0.07	-	mA	T <sub>A</sub> = +25°C
				-	-	2.9	mA	T <sub>A</sub> = +105°C
				-	-	4.4	mA	T <sub>A</sub> = +125°C
	I <sub>CCSSUB</sub>		Sub Sleep mode with CLKS1/2 = CLKP1/2 = 32kHz, (CLKMC, CLKPLL and CLKRC stopped)	-	0.04	-	mA	T <sub>A</sub> = +25°C
				-	-	2.7	mA	T <sub>A</sub> = +105°C
				-	-	4.2	mA	T <sub>A</sub> = +125°C

Parameter	Symbol	Pin Name	Conditions	Value			Unit	Remarks
				Min	Typ	Max		
Power supply current in Timer modes <sup>2</sup>	I <sub>CCTPLL</sub>	V <sub>CC</sub>	PLL Timer mode with CLKPLL = 32MHz (CLKRC and CLKSC stopped)	-	1800	2250	μA	T <sub>A</sub> = +25°C
				-	-	3220	μA	T <sub>A</sub> = +105°C
				-	-	4200	μA	T <sub>A</sub> = +125°C
	I <sub>CCTMAIN</sub>		Main Timer mode with CLKMC = 4MHz, SMCR:LPMSS = 0 (CLKPLL, CLKRC and CLKSC stopped)	-	285	330	μA	T <sub>A</sub> = +25°C
				-	-	1200	μA	T <sub>A</sub> = +105°C
				-	-	2155	μA	T <sub>A</sub> = +125°C
	I <sub>CCTRCH</sub>		RC Timer mode with CLKRC = 2MHz, SMCR:LPMSS = 0 (CLKPLL, CLKMC and CLKSC stopped)	-	160	215	μA	T <sub>A</sub> = +25°C
				-	-	1110	μA	T <sub>A</sub> = +105°C
				-	-	2065	μA	T <sub>A</sub> = +125°C
	I <sub>CCTRCL</sub>		RC Timer mode with CLKRC = 100kHz (CLKPLL, CLKMC and CLKSC stopped)	-	35	75	μA	T <sub>A</sub> = +25°C
				-	-	910	μA	T <sub>A</sub> = +105°C
				-	-	1870	μA	T <sub>A</sub> = +125°C
	I <sub>CCTSUB</sub>		Sub Timer mode with CLKSC = 32kHz (CLKMC, CLKPLL and CLKRC stopped)	-	25	65	μA	T <sub>A</sub> = +25°C
				-	-	885	μA	T <sub>A</sub> = +105°C
				-	-	1845	μA	T <sub>A</sub> = +125°C

Parameter	Symbol	Pin Name	Conditions	Value			Unit	Remarks	
				Min	Typ	Max			
Power supply current in Stop mode <sup>*3</sup>	I <sub>CCH</sub>	V <sub>CC</sub>	-	-	20	60	μA	T <sub>A</sub> = +25°C	
				-	-	880	μA	T <sub>A</sub> = +105°C	
				-	-	1840	μA	T <sub>A</sub> = +125°C	
Flash Power Down current	I <sub>CCFLASHPD</sub>		-	-	36	70	μA		
Power supply current for active Low Voltage detector <sup>*4</sup>	I <sub>CCLVD</sub>		V <sub>CC</sub>	Low voltage detector enabled	-	5	-	μA	T <sub>A</sub> = +25°C
					-	-	12.5	μA	T <sub>A</sub> = +125°C
Flash Write/ Erase current <sup>*5</sup>	I <sub>CCFLASH</sub>	V <sub>CC</sub>		-	-	12.5	-	mA	T <sub>A</sub> = +25°C
					-	-	20	mA	T <sub>A</sub> = +125°C

\*1: The power supply current is measured with a 4MHz external clock connected to the Main oscillator and a 32kHz external clock connected to the Sub oscillator. See chapter "Standby mode and voltage regulator control circuit" of the Hardware Manual for further details about voltage regulator control. Current for "On Chip Debugger" part is not included. Power supply current in Run mode does not include Flash Write / Erase current.

\*2: The power supply current in Timer mode is the value when Flash is in Power-down / reset mode. When Flash is not in Power-down / reset mode, I<sub>CCFLASHPD</sub> must be added to the Power supply current. The power supply current is measured with a 4MHz external clock connected to the Main oscillator and a 32kHz external clock connected to the Sub oscillator. The current for "On Chip Debugger" part is not included.

\*3: The power supply current in Stop mode is the value when Flash is in Power-down / reset mode. When Flash is not in Power-down / reset mode, I<sub>CCFLASHPD</sub> must be added to the Power supply current.

\*4: When low voltage detector is enabled, I<sub>CCLVD</sub> must be added to Power supply current.

\*5: When Flash Write / Erase program is executed, I<sub>CCFLASH</sub> must be added to Power supply current.

**13.3.2 Pin Characteristics**
 $(V_{CC} = AV_{CC} = 2.7V \text{ to } 5.5V, V_{SS} = AV_{SS} = 0V, T_A = -40^\circ\text{C to } +125^\circ\text{C})$ 

Parameter	Symbol	Pin Name	Conditions	Value			Unit	Remarks
				Min	Typ	Max		
"H" level input voltage	V <sub>IH</sub>	Port inputs Pnn_m	-	V <sub>CC</sub> × 0.7	-	V <sub>CC</sub> + 0.3	V	CMOS Hysteresis input
			-	V <sub>CC</sub> × 0.8	-	V <sub>CC</sub> + 0.3	V	AUTOMOTIVE Hysteresis input
	V <sub>IHX0S</sub>	X0	External clock in "Fast Clock Input mode"	V <sub>D</sub> × 0.8	-	V <sub>D</sub>	V	V <sub>D</sub> =1.8V±0.15V
	V <sub>IHX0AS</sub>	X0A	External clock in "Oscillation mode"	V <sub>CC</sub> × 0.8	-	V <sub>CC</sub> + 0.3	V	
	V <sub>IHR</sub>	RSTX	-	V <sub>CC</sub> × 0.8	-	V <sub>CC</sub> + 0.3	V	CMOS Hysteresis input
	V <sub>IHM</sub>	MD	-	V <sub>CC</sub> - 0.3	-	V <sub>CC</sub> + 0.3	V	CMOS Hysteresis input
	V <sub>IHD</sub>	DEBUG I/F	-	2.0	-	V <sub>CC</sub> + 0.3	V	TTL Input
"L" level input voltage	V <sub>IL</sub>	Port inputs Pnn_m	-	V <sub>SS</sub> - 0.3	-	V <sub>CC</sub> × 0.3	V	CMOS Hysteresis input
			-	V <sub>SS</sub> - 0.3	-	V <sub>CC</sub> × 0.5	V	AUTOMOTIVE Hysteresis input
	V <sub>ILX0S</sub>	X0	External clock in "Fast Clock Input mode"	V <sub>SS</sub>	-	V <sub>D</sub> × 0.2	V	V <sub>D</sub> =1.8V±0.15V
	V <sub>ILX0AS</sub>	X0A	External clock in "Oscillation mode"	V <sub>SS</sub> - 0.3	-	V <sub>CC</sub> × 0.2	V	
	V <sub>ILR</sub>	RSTX	-	V <sub>SS</sub> - 0.3	-	V <sub>CC</sub> × 0.2	V	CMOS Hysteresis input
	V <sub>ILM</sub>	MD	-	V <sub>SS</sub> - 0.3	-	V <sub>SS</sub> + 0.3	V	CMOS Hysteresis input
	V <sub>ILD</sub>	DEBUG I/F	-	V <sub>SS</sub> - 0.3	-	0.8	V	TTL Input

Parameter	Symbol	Pin Name	Conditions	Value			Unit	Remarks
				Min	Typ	Max		
"H" level output voltage	V <sub>OH4</sub>	4mA type	4.5V ≤ V <sub>CC</sub> ≤ 5.5V I <sub>OH</sub> = -4mA	V <sub>CC</sub> - 0.5	-	V <sub>CC</sub>	V	
			2.7V ≤ V <sub>CC</sub> < 4.5V I <sub>OH</sub> = -1.5mA					
	V <sub>OH20</sub>	High Drive type*	4.5V ≤ V <sub>CC</sub> ≤ 5.5V I <sub>OH</sub> = -20mA	V <sub>CC</sub> - 0.6	-	V <sub>CC</sub>	V	
2.7V ≤ V <sub>CC</sub> < 4.5V I <sub>OH</sub> = -13mA								
V <sub>OH3</sub>	3mA type	4.5V ≤ V <sub>CC</sub> ≤ 5.5V I <sub>OH</sub> = -3mA	V <sub>CC</sub> - 0.5	-	V <sub>CC</sub>	V		
		2.7V ≤ V <sub>CC</sub> < 4.5V I <sub>OH</sub> = -1.5mA						
"L" level output voltage	V <sub>OL4</sub>	4mA type	4.5V ≤ V <sub>CC</sub> ≤ 5.5V I <sub>OL</sub> = +4mA	-	-	0.4	V	
			2.7V ≤ V <sub>CC</sub> < 4.5V I <sub>OL</sub> = +1.7mA					
	V <sub>OL20</sub>	High Drive type*	4.5V ≤ V <sub>CC</sub> ≤ 5.5V I <sub>OL</sub> = +20mA	-	-	0.6	V	
			2.7V ≤ V <sub>CC</sub> < 4.5V I <sub>OL</sub> = +13mA					
V <sub>OL3</sub>	3mA type	2.7V ≤ V <sub>CC</sub> < 5.5V I <sub>OL</sub> = +3mA	-	-	0.4	V		
V <sub>OLD</sub>	DEBUG I/F	V <sub>CC</sub> = 2.7V I <sub>OL</sub> = +25mA	0	-	0.25	V		

Parameter	Symbol	Pin Name	Conditions	Value			Unit	Remarks
				Min	Typ	Max		
Input leak current	I <sub>IL</sub>	Pnn_m	V <sub>SS</sub> < V <sub>I</sub> < V <sub>CC</sub> AV <sub>SS</sub> , AV <sub>RL</sub> < V <sub>I</sub> < AV <sub>CC</sub> , AV <sub>RH</sub>	- 1	-	+ 1	μA	
		P08_m, P09_m, P10_m	V <sub>SS</sub> < V <sub>I</sub> < V <sub>CC</sub> AV <sub>SS</sub> , AV <sub>RL</sub> < V <sub>I</sub> < AV <sub>CC</sub> , AV <sub>RH</sub>	- 3	-	+ 3	μA	
Total LCD leak current	Σ I <sub>ILCD</sub>	All SEG/ COM pin	V <sub>CC</sub> = 5.0V	-	0.5	10	μA	Maximum leakage current of all LCD pins
Internal LCD divide resistance	R <sub>LCD</sub>	Between V3 and V2, V2 and V1, V1 and V0	V <sub>CC</sub> = 5.0V	6.25	12.5	25	kΩ	
Pull-up resistance value	R <sub>PU</sub>	Pnn_m	V <sub>CC</sub> = 5.0V ±10%	25	50	100	kΩ	
Input capacitance	C <sub>IN</sub>	Other than C, V <sub>CC</sub> , V <sub>SS</sub> , AV <sub>CC</sub> , AV <sub>SS</sub> , AV <sub>RH</sub> , AV <sub>RL</sub> , P08_m, P09_m, P10_m	-	-	5	15	pF	
		P08_m, P09_m, P10_m	-	-	15	30	pF	

\*: In the case of high current outputs, set "1" to the bit in the Port High Drive Register.

13.4 AC Characteristics

13.4.1 Main Clock Input Characteristics

( $V_{CC} = AV_{CC} = 2.7V$  to  $5.5V$ ,  $V_D = 1.8V \pm 0.15V$ ,  $V_{SS} = AV_{SS} = 0V$ ,  $T_A = -40^\circ C$  to  $+125^\circ C$ )

Parameter	Symbol	Pin Name	Value			Unit	Remarks
			Min	Typ	Max		
Input frequency	$f_c$	X0, X1	4	-	8	MHz	When using a crystal oscillator, PLL off
			-	-	8	MHz	When using an opposite phase external clock, PLL off
			4	-	8	MHz	When using a crystal oscillator or opposite phase external clock, PLL on
Input frequency	$f_{FCI}$	X0	-	-	8	MHz	When using a single phase external clock in "Fast Clock Input mode", PLL off
			4	-	8	MHz	When using a single phase external clock in "Fast Clock Input mode", PLL on
Input clock cycle	$t_{CYLH}$	-	125	-	-	ns	
Input clock pulse width	$P_{WH}, P_{WL}$	-	55	-	-	ns	

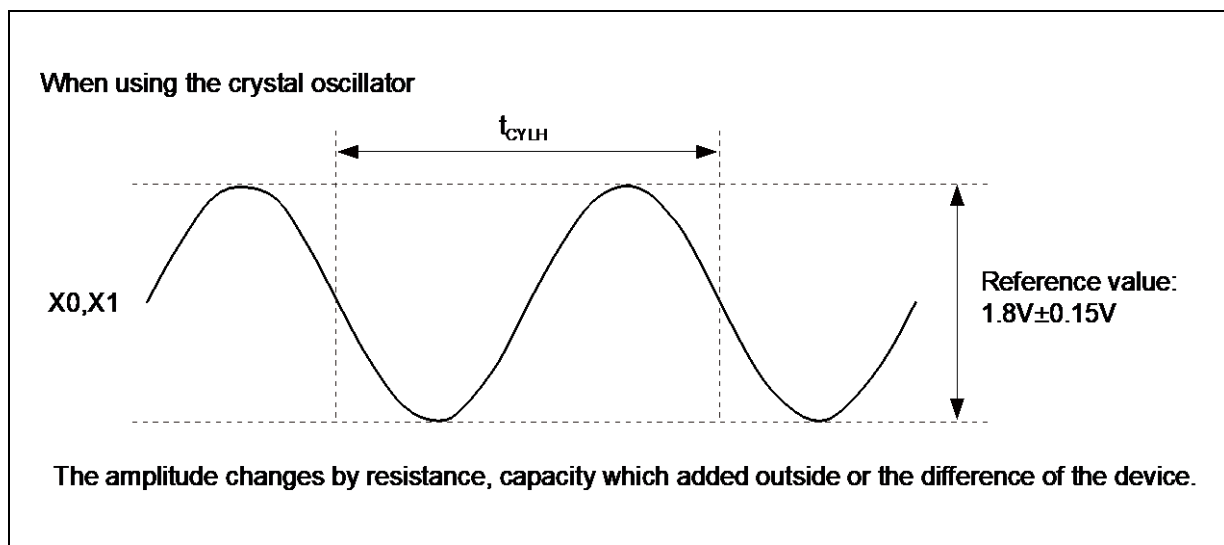

**When using the external clock**

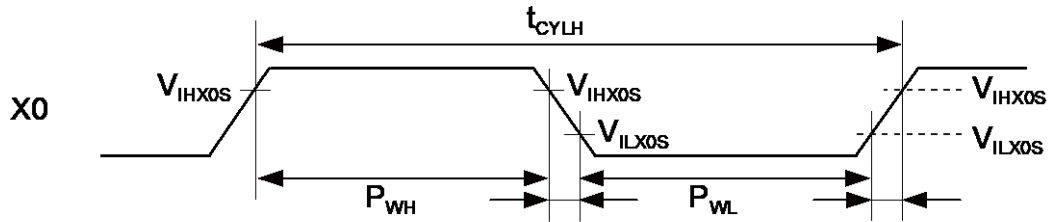

13.4.2 Sub Clock Input Characteristics

( $V_{CC} = AV_{CC} = 2.7V$  to  $5.5V$ ,  $V_{SS} = AV_{SS} = 0V$ ,  $T_A = -40^{\circ}C$  to  $+125^{\circ}C$ )

Parameter	Symbol	Pin Name	Conditions	Value			Unit	Remarks
				Min	Typ	Max		
Input frequency	$f_{CL}$	X0A, X1A	-	-	32.768	-	kHz	When using an oscillation circuit
			-	-	-	100		kHz
		X0A	-	-	-	50	kHz	When using a single phase external clock
Input clock cycle	$t_{CYLL}$	-	-	10	-	-	$\mu s$	
Input clock pulse width	-	-	$P_{WH}/t_{CYLL}$ , $P_{WL}/t_{CYLL}$	30	-	70	%	

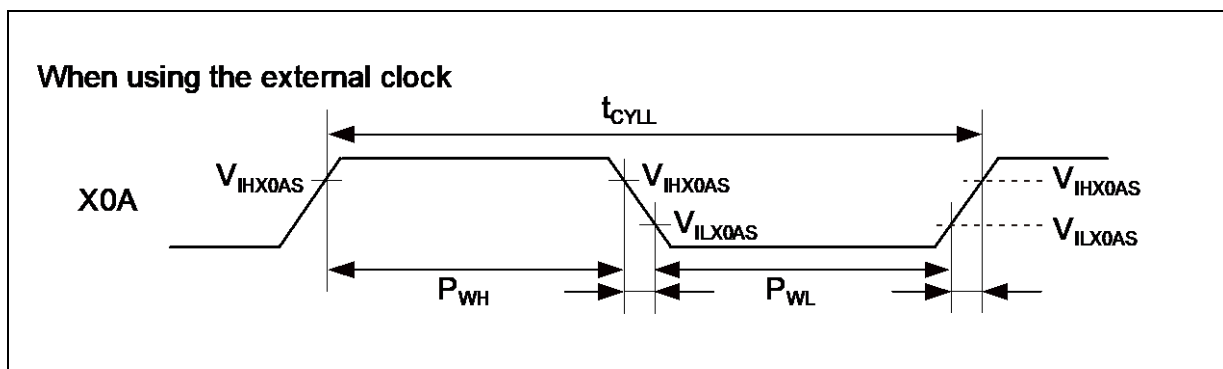
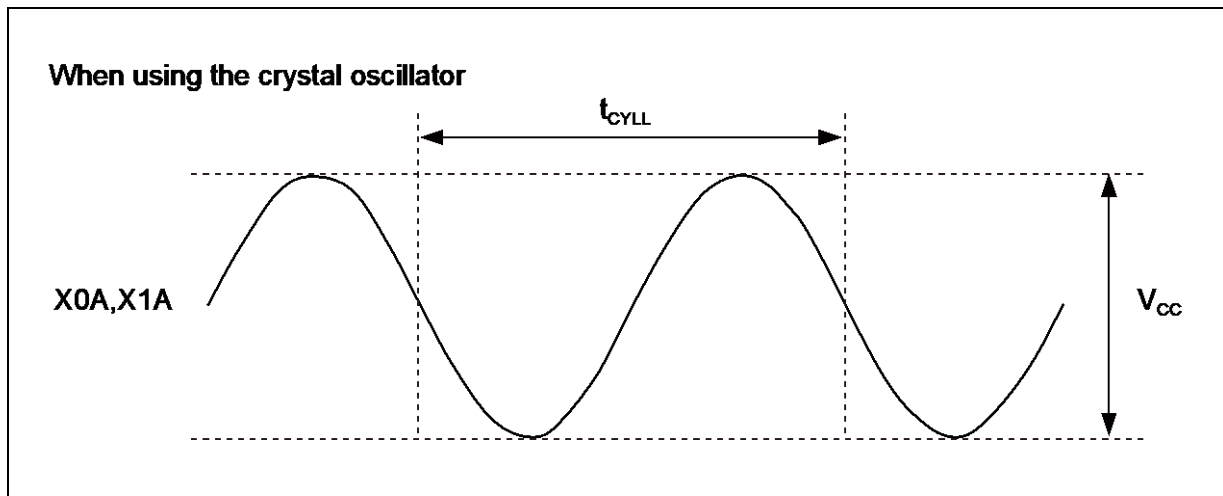

**13.4.3 Built-in RC Oscillation Characteristics**
 $(V_{CC} = AV_{CC} = 2.7V \text{ to } 5.5V, V_{SS} = AV_{SS} = 0V, T_A = -40^{\circ}C \text{ to } +125^{\circ}C)$ 

Parameter	Symbol	Value			Unit	Remarks
		Min	Typ	Max		
Clock frequency	$f_{RC}$	50	100	200	kHz	When using slow frequency of RC oscillator
		1	2	4		MHz
RC clock stabilization time	$t_{RCSTAB}$	80	160	320	$\mu$ s	When using slow frequency of RC oscillator (16 RC clock cycles)
		64	128	256	$\mu$ s	When using fast frequency of RC oscillator (256 RC clock cycles)

**13.4.4 Internal Clock Timing**
 $(V_{CC} = AV_{CC} = 2.7V \text{ to } 5.5V, V_{SS} = AV_{SS} = 0V, T_A = -40^{\circ}C \text{ to } +125^{\circ}C)$ 

Parameter	Symbol	Value		Unit
		Min	Max	
Internal System clock frequency (CLKS1 and CLKS2)	$f_{CLKS1}, f_{CLKS2}$	-	54	MHz
Internal CPU clock frequency (CLKB), Internal peripheral clock frequency (CLKP1)	$f_{CLKB}, f_{CLKP1}$	-	32	MHz
Internal peripheral clock frequency (CLKP2)	$f_{CLKP2}$	-	32	MHz

13.4.5 Operating Conditions of PLL

( $V_{CC} = AV_{CC} = 2.7V$  to  $5.5V$ ,  $V_{SS} = AV_{SS} = 0V$ ,  $T_A = -40^{\circ}C$  to  $+125^{\circ}C$ )

Parameter	Symbol	Value			Unit	Remarks
		Min	Typ	Max		
PLL oscillation stabilization wait time	$t_{LOCK}$	1	-	4	ms	For CLKMC = 4MHz
PLL input clock frequency	$f_{PLLI}$	4	-	8	MHz	
PLL oscillation clock frequency	$f_{CLKVCO}$	56	-	108	MHz	Permitted VCO output frequency of PLL (CLKVCO)
PLL phase jitter	$t_{PSKEW}$	-5	-	+5	ns	For CLKMC (PLL input clock) $\geq$ 4MHz

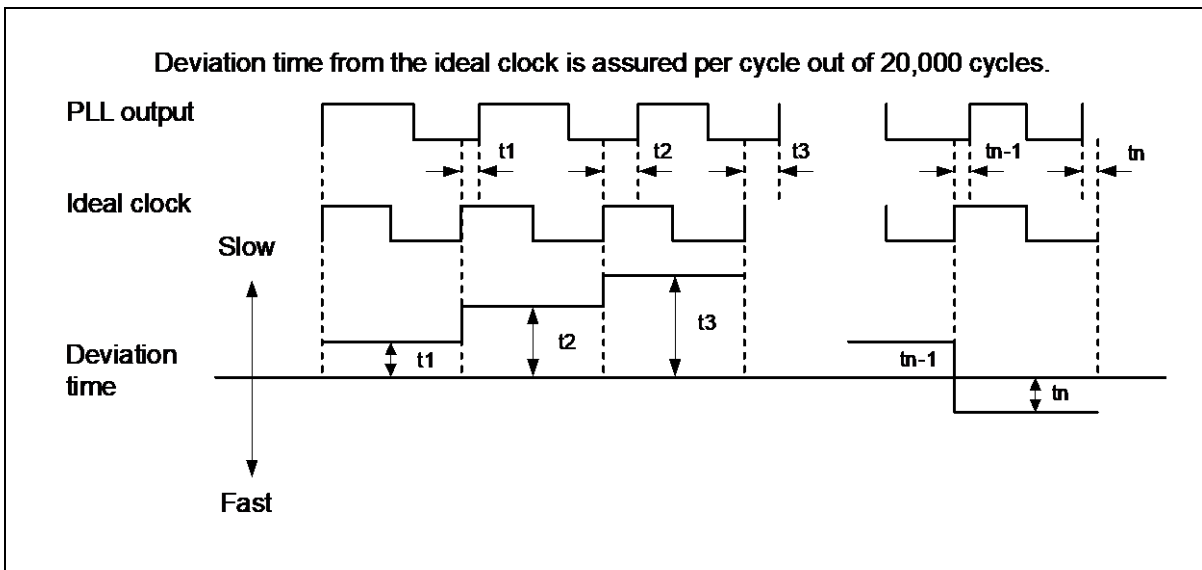

13.4.6 Reset Input

( $V_{CC} = AV_{CC} = 2.7V$  to  $5.5V$ ,  $V_{SS} = AV_{SS} = 0V$ ,  $T_A = -40^{\circ}C$  to  $+125^{\circ}C$ )

Parameter	Symbol	Pin Name	Value		Unit
			Min	Max	
Reset input time	$t_{RSTL}$	RSTX	10	-	$\mu S$
Rejection of reset input time			1	-	$\mu S$

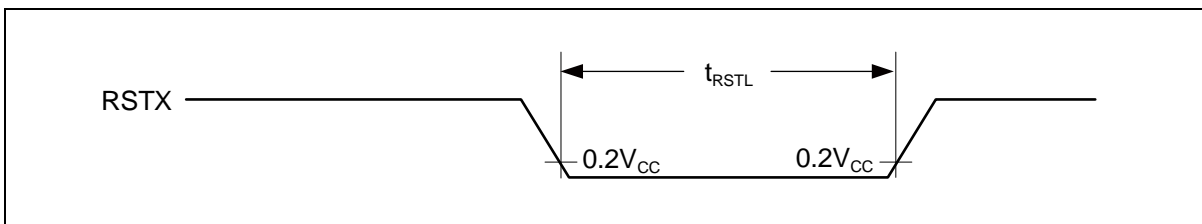

13.4.7 Power-on Reset Timing

( $V_{CC} = AV_{CC} = 2.7V$  to  $5.5V$ ,  $V_{SS} = AV_{SS} = 0V$ ,  $T_A = -40^{\circ}C$  to  $+125^{\circ}C$ )

Parameter	Symbol	Pin Name	Value			Unit
			Min	Typ	Max	
Power on rise time	$t_R$	VCC	0.05	-	30	ms
Power off time	$t_{OFF}$	VCC	1	-	-	ms

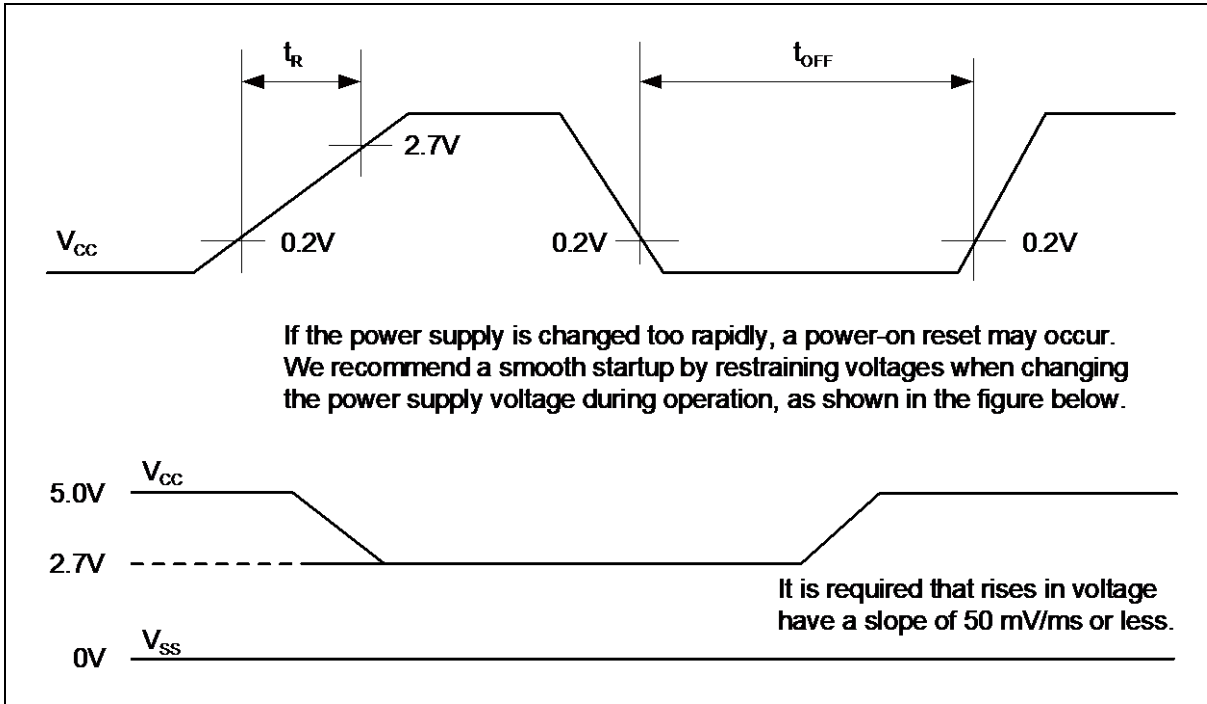

13.4.8 USART Timing

( $V_{CC} = AV_{CC} = 2.7V$  to  $5.5V$ ,  $V_{SS} = AV_{SS} = 0V$ ,  $T_A = -40^{\circ}C$  to  $+125^{\circ}C$ ,  $C_L = 50pF$ )

Parameter	Symbol	Pin Name	Conditions	$4.5V \leq V_{CC} < 5.5V$		$2.7V \leq V_{CC} < 4.5V$		Unit
				Min	Max	Min	Max	
Serial clock cycle time	$t_{SCYC}$	SCKn	Internal shift clock mode	$4t_{CLKP1}$	-	$4t_{CLKP1}$	-	ns
SCK ↓ → SOT delay time	$t_{SLOV1}$	SCKn, SOTn		- 20	+ 20	- 30	+ 30	ns
SOT → SCK ↑ delay time	$t_{OVSH1}$	SCKn, SOTn		$N \times t_{CLKP1} - 20$	-	$N \times t_{CLKP1} - 30$	-	ns
SIN → SCK ↑ setup time	$t_{IVSH1}$	SCKn, SINn		$t_{CLKP1} + 45$	-	$t_{CLKP1} + 55$	-	ns
SCK ↑ → SIN hold time	$t_{SHIX1}$	SCKn, SINn		0	-	0	-	ns
Serial clock "L" pulse width	$t_{SLSH}$	SCKn	External shift clock mode	$t_{CLKP1} + 10$	-	$t_{CLKP1} + 10$	-	ns
Serial clock "H" pulse width	$t_{SHSL}$	SCKn		$t_{CLKP1} + 10$	-	$t_{CLKP1} + 10$	-	ns
SCK ↓ → SOT delay time	$t_{SLOVE}$	SCKn, SOTn		-	$2t_{CLKP1} + 45$	-	$2t_{CLKP1} + 55$	ns
SIN → SCK ↑ setup time	$t_{IVSHE}$	SCKn, SINn		$t_{CLKP1}/2 + 10$	-	$t_{CLKP1}/2 + 10$	-	ns
SCK ↑ → SIN hold time	$t_{SHIXE}$	SCKn, SINn		$t_{CLKP1} + 10$	-	$t_{CLKP1} + 10$	-	ns
SCK fall time	$t_F$	SCKn		-	20	-	20	ns
SCK rise time	$t_R$	SCKn		-	20	-	20	ns

- Notes:
- AC characteristic in CLK synchronized mode.
  - CL is the load capacity value of pins when testing.
  - Depending on the used machine clock frequency, the maximum possible baud rate can be limited by some parameters. These parameters are shown in "CY96600 series HARDWARE MANUAL".
  - $t_{CLKP1}$  indicates the peripheral clock 1 (CLKP1), Unit: ns
  - These characteristics only guarantee the same relocate port number.  
For example, the combination of SCKn and SOTn\_R is not guaranteed.

\*: Parameter N depends on  $t_{SCYC}$  and can be calculated as follows:

- If  $t_{SCYC} = 2 \times k \times t_{CLKP1}$ , then  $N = k$ , where k is an integer > 2
- If  $t_{SCYC} = (2 \times k + 1) \times t_{CLKP1}$ , then  $N = k + 1$ , where k is an integer > 1

Examples:

$t_{SCYC}$	N
$4 \times t_{CLKP1}$	2
$5 \times t_{CLKP1}, 6 \times t_{CLKP1}$	3
$7 \times t_{CLKP1}, 8 \times t_{CLKP1}$	4
...	...

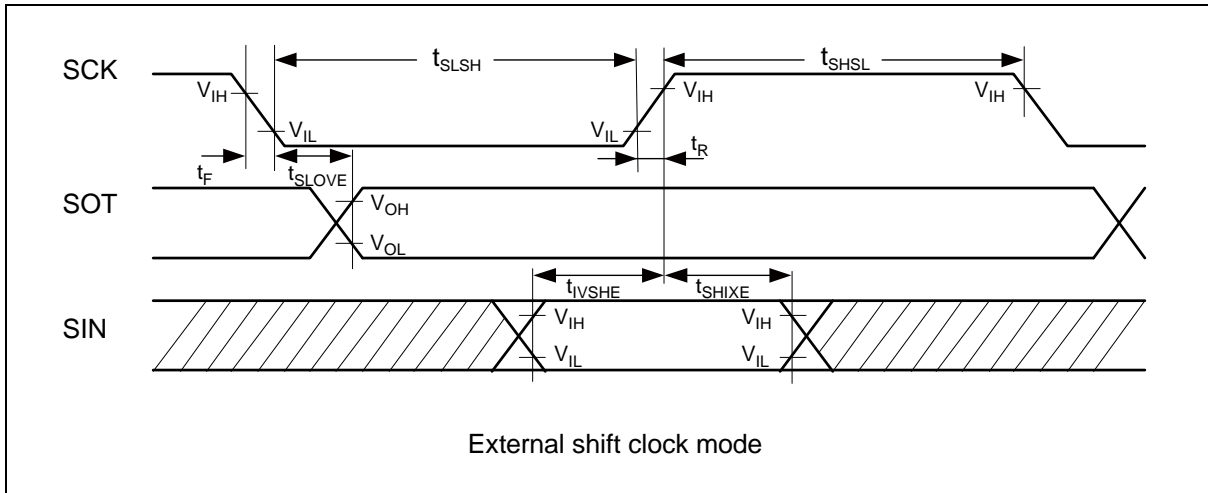
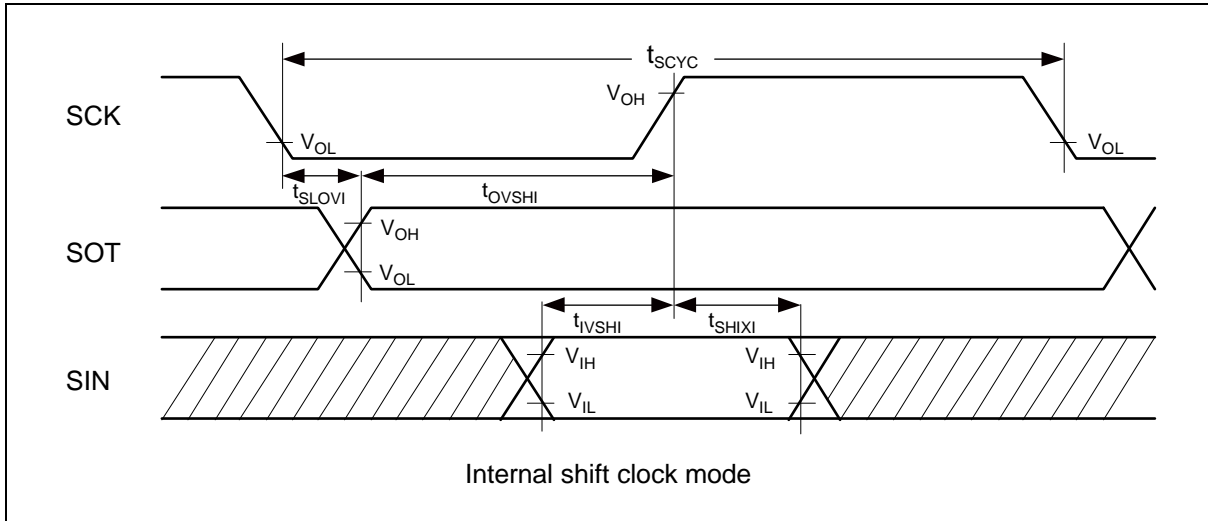

13.4.9 External Input Timing

( $V_{CC} = AV_{CC} = 2.7V$  to  $5.5V$ ,  $V_{SS} = AV_{SS} = 0V$ ,  $T_A = -40^{\circ}C$  to  $+125^{\circ}C$ )

Parameter	Symbol	Pin Name	Value		Unit	Remarks
			Min	Max		
Input pulse width	$t_{INH}$ , $t_{INL}$	Pnn_m	$2t_{CLKP1} + 200$ ( $t_{CLKP1} = 1/f_{CLKP1}$ )*	-	ns	General Purpose I/O
		ADTG				A/D Converter trigger input
		TINn, TINn_R				Reload Timer
		TTGn				PPG trigger input
		FRCKn, FRCKn_R				Free-Running Timer input clock
		INn, INn_R				Input Capture
		AINn, BINn, ZINn				Quadrature Position/Revolution Counter
		INTn, INTn_R	200	-	ns	External Interrupt
		NMI				ns

\*:  $t_{CLKP1}$  indicates the peripheral clock1 (CLKP1) cycle time except stop when in stop mode.

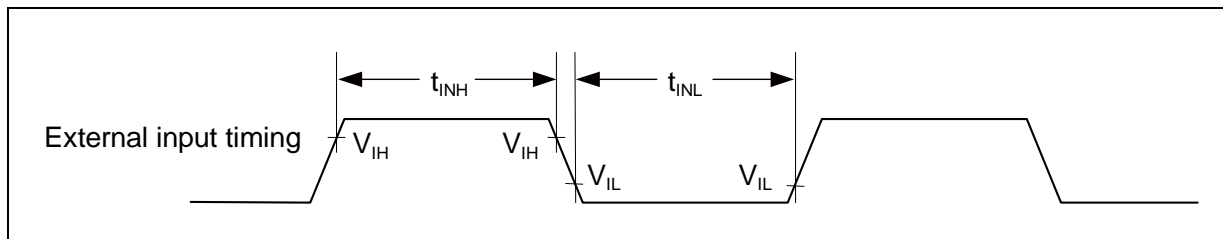

13.4.10 I<sup>2</sup>C Timing

(V<sub>CC</sub> = AV<sub>CC</sub> = 2.7V to 5.5V, V<sub>SS</sub> = AV<sub>SS</sub> = 0V, T<sub>A</sub> = - 40°C to + 125°C)

Parameter	Symbol	Conditions	Typical Mode		High-Speed Mode <sup>*4</sup>		Unit
			Min	Max	Min	Max	
SCL clock frequency	f <sub>SCL</sub>	C <sub>L</sub> = 50pF, R = (V <sub>p</sub> /I <sub>OL</sub> ) <sup>*1</sup>	0	100	0	400	kHz
(Repeated) START condition hold time SDA ↓ → SCL ↓	t <sub>HDSTA</sub>		4.0	-	0.6	-	μs
SCL clock "L" width	t <sub>LOW</sub>		4.7	-	1.3	-	μs
SCL clock "H" width	t <sub>HIGH</sub>		4.0	-	0.6	-	μs
(Repeated) START condition setup time SCL ↑ → SDA ↓	t <sub>SUSTA</sub>		4.7	-	0.6	-	μs
Data hold time SCL ↓ → SDA ↓ ↑	t <sub>HDDAT</sub>		0	3.45 <sup>*2</sup>	0	0.9 <sup>*3</sup>	μs
Data setup time SDA ↓ ↑ → SCL ↑	t <sub>SUDAT</sub>		250	-	100	-	ns
STOP condition setup time SCL ↑ → SDA ↑	t <sub>SUSTO</sub>		4.0	-	0.6	-	μs
Bus free time between "STOP condition" and "START condition"	t <sub>BUS</sub>		4.7	-	1.3	-	μs
Pulse width of spikes which will be suppressed by input noise filter	t <sub>SP</sub>		-	0	(1-1.5) × t <sub>CLKP1</sub> <sup>*5</sup>	0	(1-1.5) × t <sub>CLKP1</sub> <sup>*5</sup>

\*1: R and C<sub>L</sub> represent the pull-up resistance and load capacitance of the SCL and SDA lines, respectively.

V<sub>p</sub> indicates the power supply voltage of the pull-up resistance and I<sub>OL</sub> indicates V<sub>OL</sub> guaranteed current.

\*2: The maximum t<sub>HDDAT</sub> only has to be met if the device does not extend the "L" width (t<sub>LOW</sub>) of the SCL signal.

\*3: A high-speed mode I<sup>2</sup>C bus device can be used on a standard mode I<sup>2</sup>C bus system as long as the device satisfies the requirement of "t<sub>SUDAT</sub> ≥ 250ns".

\*4: For use at over 100kHz, set the peripheral clock1 (CLKP1) to at least 6MHz.

\*5: t<sub>CLKP1</sub> indicates the peripheral clock1 (CLKP1) cycle time.

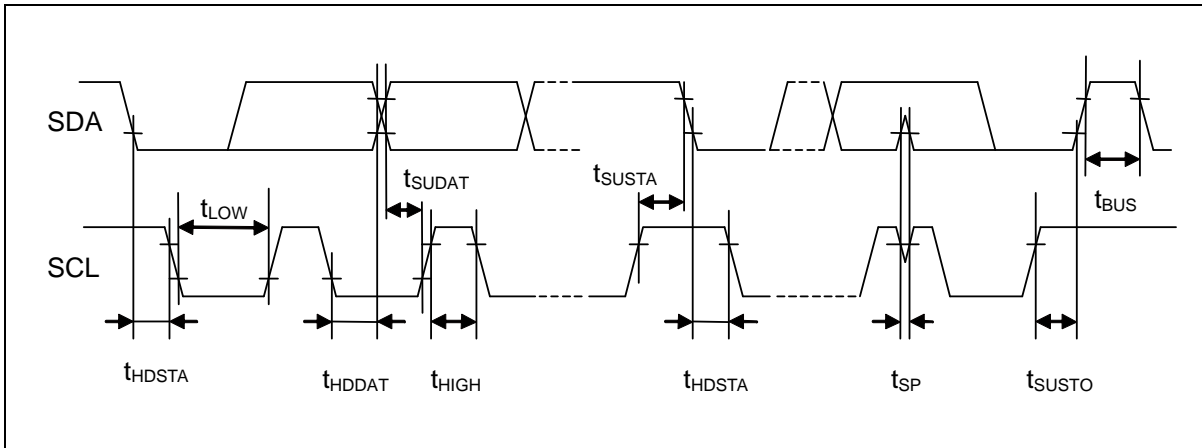

**13.5 A/D Converter**
**13.5.1 Electrical Characteristics for the A/D Converter**
 $(V_{CC} = AV_{CC} = 2.7V \text{ to } 5.5V, V_{SS} = AV_{SS} = 0V, T_A = -40^\circ C \text{ to } +125^\circ C)$ 

Parameter	Symbol	Pin Name	Value			Unit	Remarks
			Min	Typ	Max		
Resolution	-	-	-	-	10	bit	
Total error	-	-	- 3.0	-	+ 3.0	LSB	
Nonlinearity error	-	-	- 2.5	-	+ 2.5	LSB	
Differential Nonlinearity error	-	-	- 1.9	-	+ 1.9	LSB	
Zero transition voltage	$V_{OT}$	ANn	Typ - 20	AVRL + 0.5LSB	Typ + 20	mV	
Full scale transition voltage	$V_{FST}$	ANn	Typ - 20	AVRH - 1.5LSB	Typ + 20	mV	
Compare time*	-	-	1.0	-	5.0	$\mu s$	$4.5V \leq AV_{CC} \leq 5.5V$
			2.2	-	8.0	$\mu s$	$2.7V \leq AV_{CC} < 4.5V$
Sampling time*	-	-	0.5	-	-	$\mu s$	$4.5V \leq AV_{CC} \leq 5.5V$
			1.2	-	-	$\mu s$	$2.7V \leq AV_{CC} < 4.5V$
Power supply current	$I_A$	AV <sub>CC</sub>	-	2.0	3.1	mA	A/D Converter active
	$I_{AH}$		-	-	3.3	$\mu A$	A/D Converter not operated
Reference power supply current (between AVRH and AVRL)	$I_R$	AVRH	-	520	810	$\mu A$	A/D Converter active
	$I_{RH}$		-	-	1.0	$\mu A$	A/D Converter not operated
Analog input capacity	$C_{VIN}$	AN0 to 15	-	-	16.0	pF	Normal outputs
		AN16 to 31	-	-	17.8	pF	High current outputs
Analog impedance	$R_{VIN}$	ANn	-	-	2050	$\Omega$	$4.5V \leq AV_{CC} \leq 5.5V$
			-	-	3600	$\Omega$	$2.7V \leq AV_{CC} < 4.5V$
Analog port input current (during conversion)	$I_{AIN}$	AN0 to 15	- 0.3	-	+ 0.3	$\mu A$	$AV_{SS}, AVRL < V_{AIN} < AV_{CC}, AVRH$
		AN16 to 31	- 3.0	-	+ 3.0	$\mu A$	
Analog input voltage	$V_{AIN}$	ANn	AVRL	-	AVRH	V	
Reference voltage range	-	AVRH	AV <sub>CC</sub> - 0.1	-	AV <sub>CC</sub>	V	
	-	AVRL	AV <sub>SS</sub>	-	AV <sub>SS</sub> + 0.1	V	
Variation between channels	-	ANn	-	-	4.0	LSB	

\*: Time for each channel.

### 13.5.2 Accuracy and Setting of the A/D Converter Sampling Time

If the external impedance is too high or the sampling time too short, the analog voltage charged to the internal sample and hold capacitor is insufficient, adversely affecting the A/D conversion precision.

To satisfy the A/D conversion precision, a sufficient sampling time must be selected. The required sampling time ( $T_{\text{samp}}$ ) depends on the external driving impedance  $R_{\text{ext}}$ , the board capacitance of the A/D converter input pin  $C_{\text{ext}}$  and the  $AV_{\text{CC}}$  voltage level. The following replacement model can be used for the calculation:

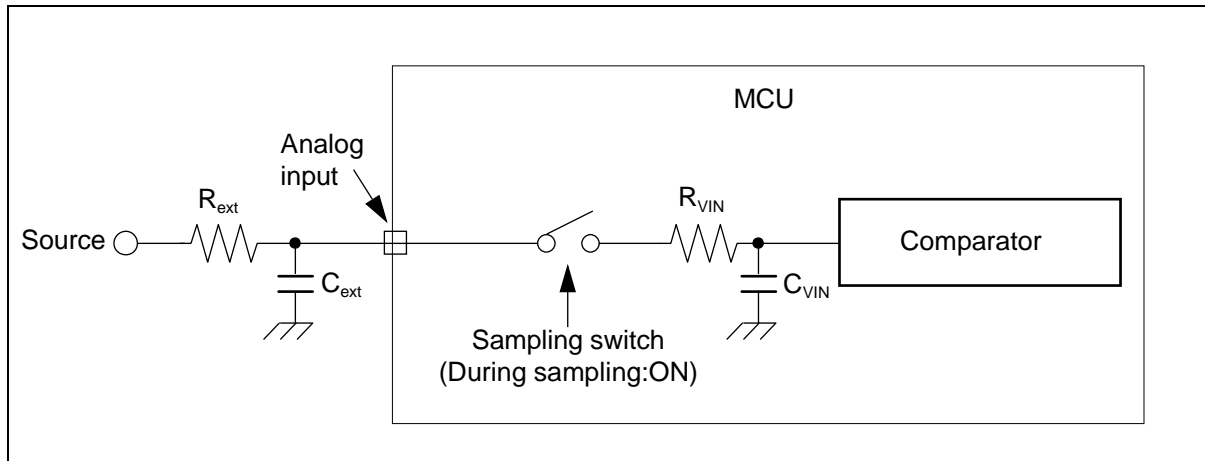

$R_{\text{ext}}$ : External driving impedance

$C_{\text{ext}}$ : Capacitance of PCB at A/D converter input

$C_{\text{VIN}}$ : Analog input capacity (I/O, analog switch and ADC are contained)

$R_{\text{VIN}}$ : Analog input impedance (I/O, analog switch and ADC are contained)

The following approximation formula for the replacement model above can be used:

$$T_{\text{samp}} = 7.62 \times (R_{\text{ext}} \times C_{\text{ext}} + (R_{\text{ext}} + R_{\text{VIN}}) \times C_{\text{VIN}})$$

- Do not select a sampling time below the absolute minimum permitted value.  
( $0.5\mu\text{s}$  for  $4.5\text{V} \leq AV_{\text{CC}} \leq 5.5\text{V}$ ,  $1.2\mu\text{s}$  for  $2.7\text{V} \leq AV_{\text{CC}} < 4.5\text{V}$ )
- If the sampling time cannot be sufficient, connect a capacitor of about  $0.1\mu\text{F}$  to the analog input pin.
- A big external driving impedance also adversely affects the A/D conversion precision due to the pin input leakage current  $I_{\text{IL}}$  (static current before the sampling switch) or the analog input leakage current  $I_{\text{AIN}}$  (total leakage current of pin input and comparator during sampling). The effect of the pin input leakage current  $I_{\text{IL}}$  cannot be compensated by an external capacitor.
- The accuracy gets worse as  $|AV_{\text{RH}} - AV_{\text{RL}}|$  becomes smaller.

13.5.3 Definition of A/D Converter Terms

- Resolution : Analog variation that is recognized by an A/D converter.
- Nonlinearity error : Deviation of the actual conversion characteristics from a straight line that connects the zero transition point (0b0000000000 ↔ 0b0000000001) to the full-scale transition point (0b1111111110 ↔ 0b1111111111).
- Differential nonlinearity error : Deviation from the ideal value of the input voltage that is required to change the output code by 1LSB.
- Total error : Difference between the actual value and the theoretical value. The total error includes zero transition error, full-scale transition error and nonlinearity error.
- Zero transition voltage: Input voltage which results in the minimum conversion value.
- Full scale transition voltage: Input voltage which results in the maximum conversion value.

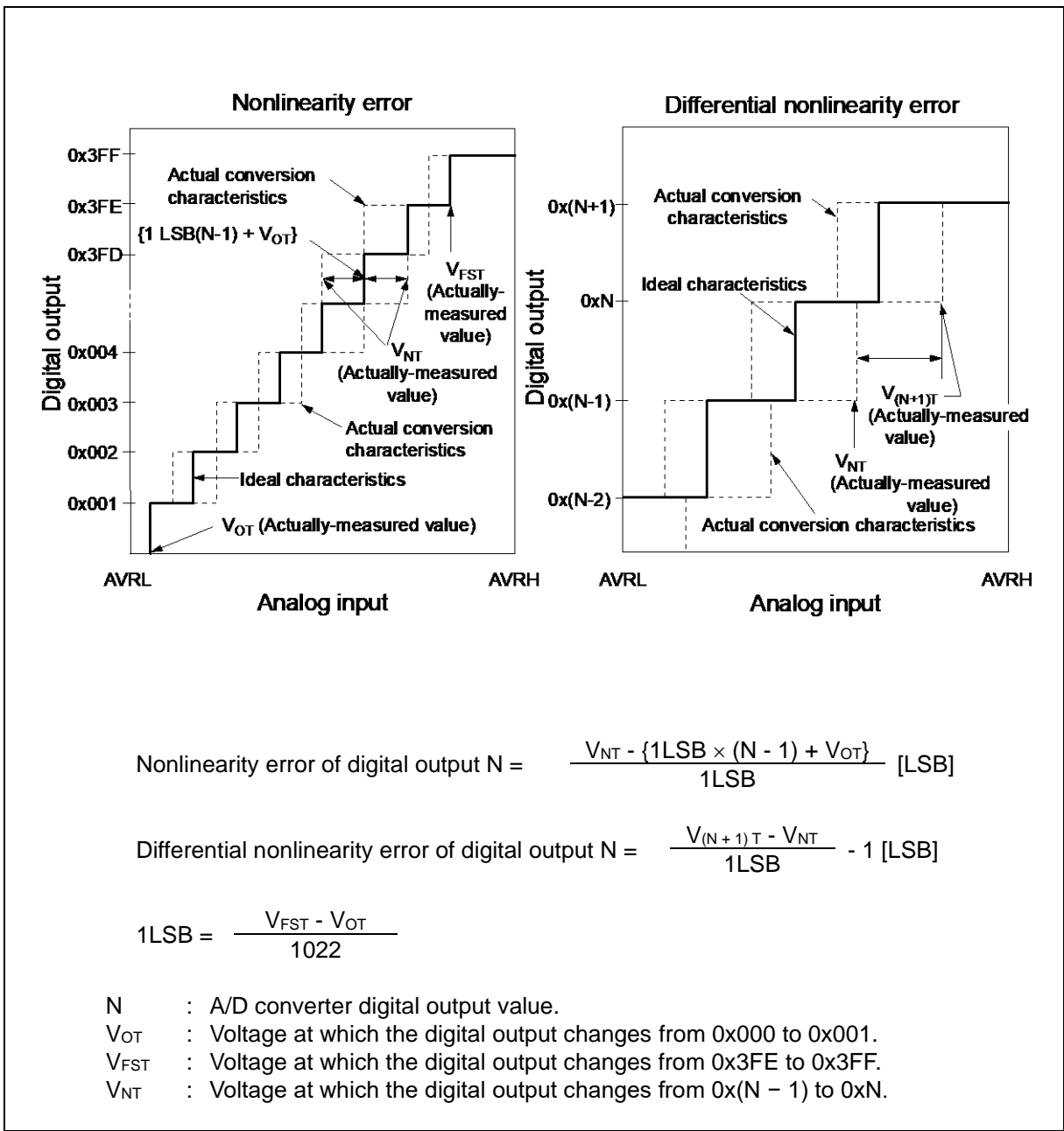

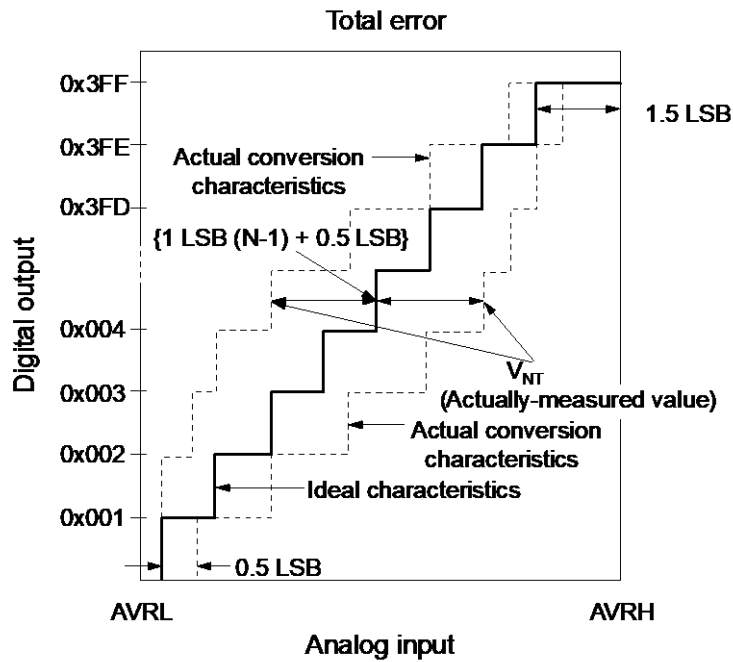

$$1\text{LSB (Ideal value)} = \frac{\text{AVRH} - \text{AVRL}}{1024} \text{ [V]}$$

$$\text{Total error of digital output N} = \frac{V_{NT} - \{1\text{LSB} \times (N - 1) + 0.5\text{LSB}\}}{1\text{LSB}}$$

N : A/D converter digital output value.

$V_{NT}$  : Voltage at which the digital output changes from  $0x(N + 1)$  to  $0xN$ .

$V_{OT}$  (Ideal value) =  $\text{AVRL} + 0.5\text{LSB}$ [V]

$V_{FST}$  (Ideal value) =  $\text{AVRH} - 1.5\text{LSB}$ [V]

### 13.6 High Current Output Slew Rate

( $V_{CC} = AV_{CC} = 2.7V$  to  $5.5V$ ,  $V_{SS} = AV_{SS} = 0V$ ,  $T_A = -40^{\circ}C$  to  $+125^{\circ}C$ )

Parameter	Symbol	Pin Name	Conditions	Value			Unit	Remarks
				Min	Typ	Max		
Output rise/fall time	$t_{R20}$ , $t_{F20}$	P08_m, P09_m, P10_m	Outputs driving strength set to "20mA"	15	-	75	ns	$C_L=85pF$

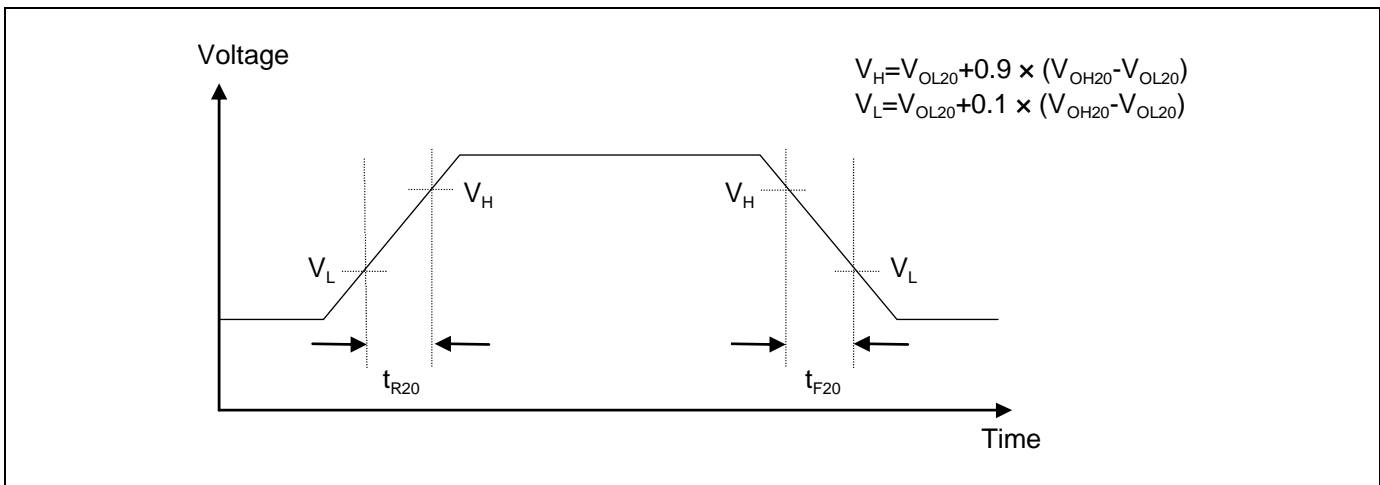

**13.7 Low Voltage Detection Function Characteristics**
 $(V_{CC} = AV_{CC} = 2.7V \text{ to } 5.5V, V_{SS} = AV_{SS} = 0V, T_A = -40^{\circ}C \text{ to } +125^{\circ}C)$ 

Parameter	Symbol	Conditions	Value			Unit
			Min	Typ	Max	
Detected voltage <sup>*1</sup>	V <sub>DL0</sub>	CILCR:LVL = 0000 <sub>B</sub>	2.70	2.90	3.10	V
	V <sub>DL1</sub>	CILCR:LVL = 0001 <sub>B</sub>	2.79	3.00	3.21	V
	V <sub>DL2</sub>	CILCR:LVL = 0010 <sub>B</sub>	2.98	3.20	3.42	V
	V <sub>DL3</sub>	CILCR:LVL = 0011 <sub>B</sub>	3.26	3.50	3.74	V
	V <sub>DL4</sub>	CILCR:LVL = 0100 <sub>B</sub>	3.45	3.70	3.95	V
	V <sub>DL5</sub>	CILCR:LVL = 0111 <sub>B</sub>	3.73	4.00	4.27	V
	V <sub>DL6</sub>	CILCR:LVL = 1001 <sub>B</sub>	3.91	4.20	4.49	V
Power supply voltage change rate <sup>*2</sup>	dV/dt	-	-0.004	-	+0.004	V/μs
Hysteresis width	V <sub>HYS</sub>	CILCR:LVHYS=0	-	-	50	mV
		CILCR:LVHYS=1	80	100	120	mV
Stabilization time	T <sub>LVDSTAB</sub>	-	-	75	μs	
Detection delay time	t <sub>d</sub>	-	-	30	μs	

\*1: If the power supply voltage fluctuates within the time less than the detection delay time (t<sub>d</sub>), there is a possibility that the low voltage detection will occur or stop after the power supply voltage passes the detection range.

\*2: In order to perform the low voltage detection at the detection voltage (V<sub>DLX</sub>), be sure to suppress fluctuation of the power supply voltage within the limits of the change ration of power supply voltage.

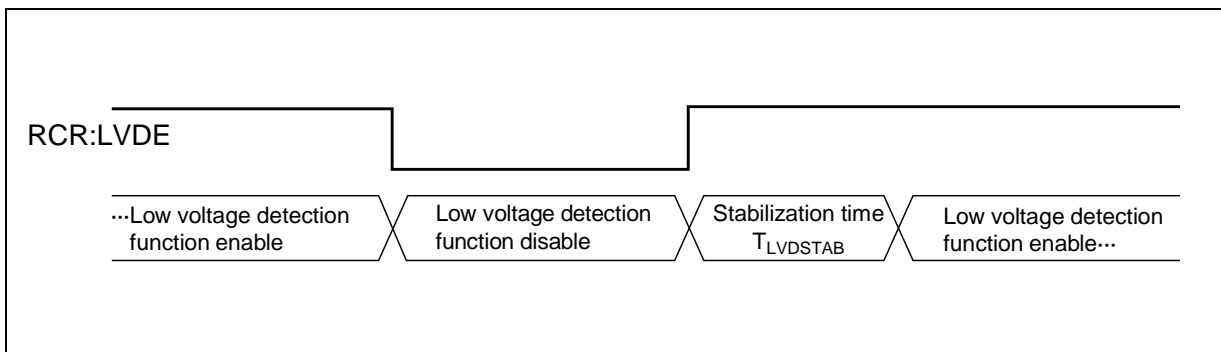
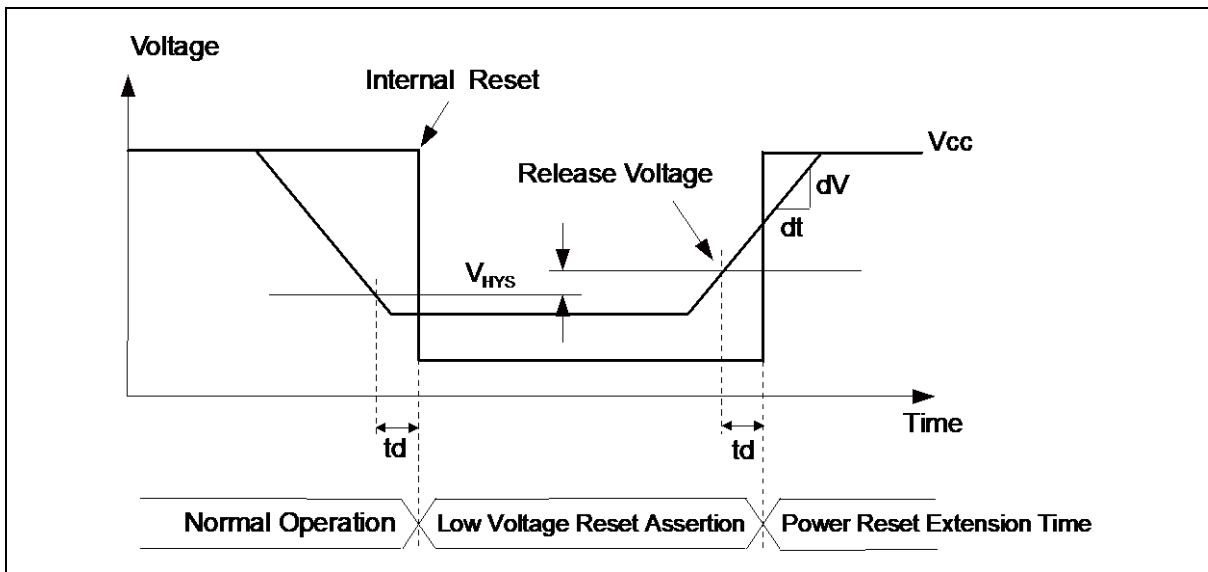
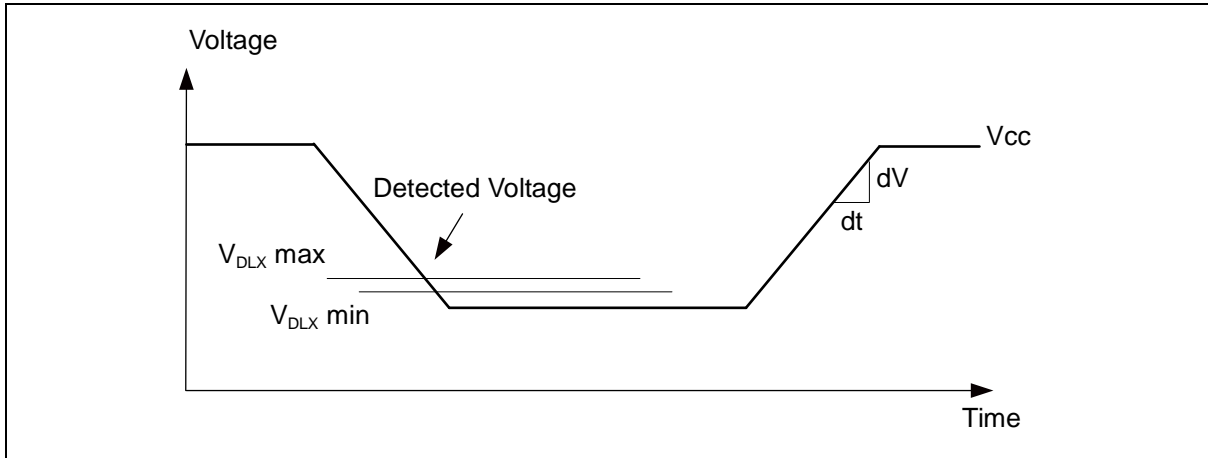

13.8 Flash Memory Write/Erase Characteristics

( $V_{CC} = AV_{CC} = 2.7V$  to  $5.5V$ ,  $V_{SS} = AV_{SS} = 0V$ ,  $T_A = -40^{\circ}C$  to  $+125^{\circ}C$ )

Parameter		Conditions	Value			Unit	Remarks
			Min	Typ	Max		
Sector erase time	Large Sector	$T_A \leq +105^{\circ}C$	-	1.6	7.5	s	Includes write time prior to internal erase.
	Small Sector	-	-	0.4	2.1	s	
	Security Sector	-	-	0.31	1.65	s	
Word (16-bit) write time	Large Sector	$T_A \leq +105^{\circ}C$	-	25	400	$\mu s$	Not including system-level overhead time.
	Small Sector	-	-	25	400	$\mu s$	
Chip erase time		$T_A \leq +105^{\circ}C$	-	8.31	40.05	s	Includes write time prior to internal erase.

Note: While the Flash memory is written or erased, shutdown of the external power ( $V_{CC}$ ) is prohibited. In the application system where the external power ( $V_{CC}$ ) might be shut down while writing or erasing, be sure to turn the power off by using a low voltage detection function.

To put it concrete, change the external power in the range of change ration of power supply voltage ( $-0.004V/\mu s$  to  $+0.004V/\mu s$ ) after the external power falls below the detection voltage ( $V_{DLX}$ )\*1.

Write/Erase cycles and data hold time

Write/Erase Cycles (Cycle)	Data Hold Time (Year)
1,000	$20^{-2}$
10,000	$10^{-2}$
100,000	$5^{-2}$

\*1: See "14.7. Low Voltage Detection Function Characteristics".

\*2: This value comes from the technology qualification (using Arrhenius equation to translate high temperature measurements into normalized value at  $+85^{\circ}C$ ).

### 14. Example Characteristics

This characteristic is an actual value of the arbitrary sample. It is not the guaranteed value.

CY96F6C6

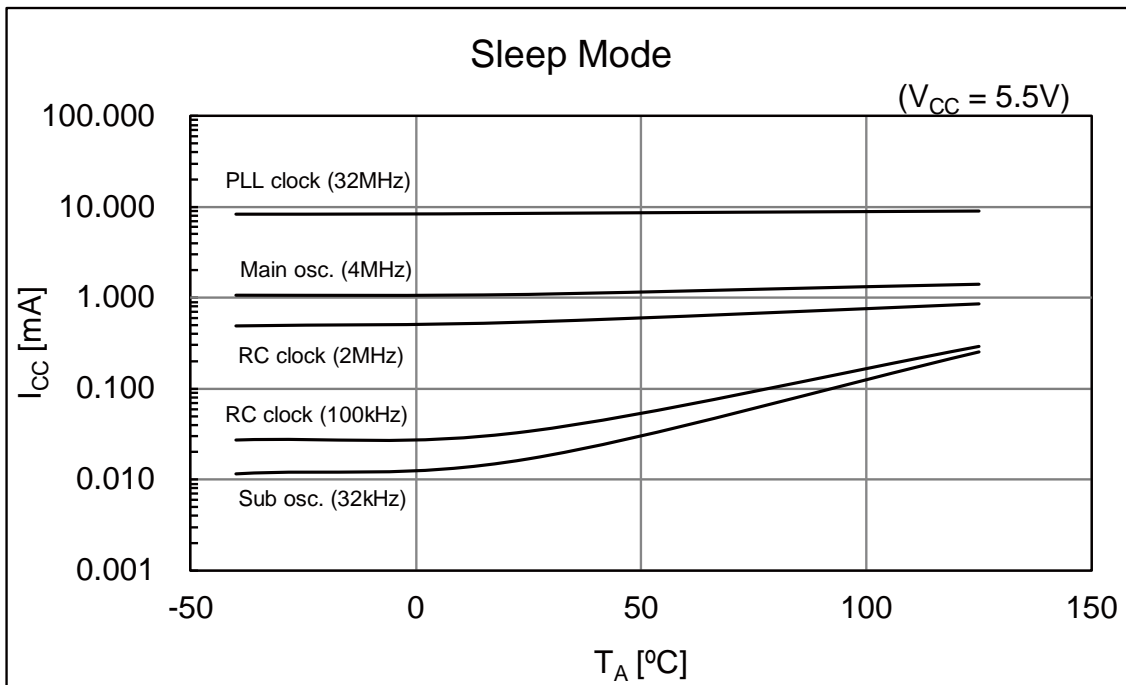
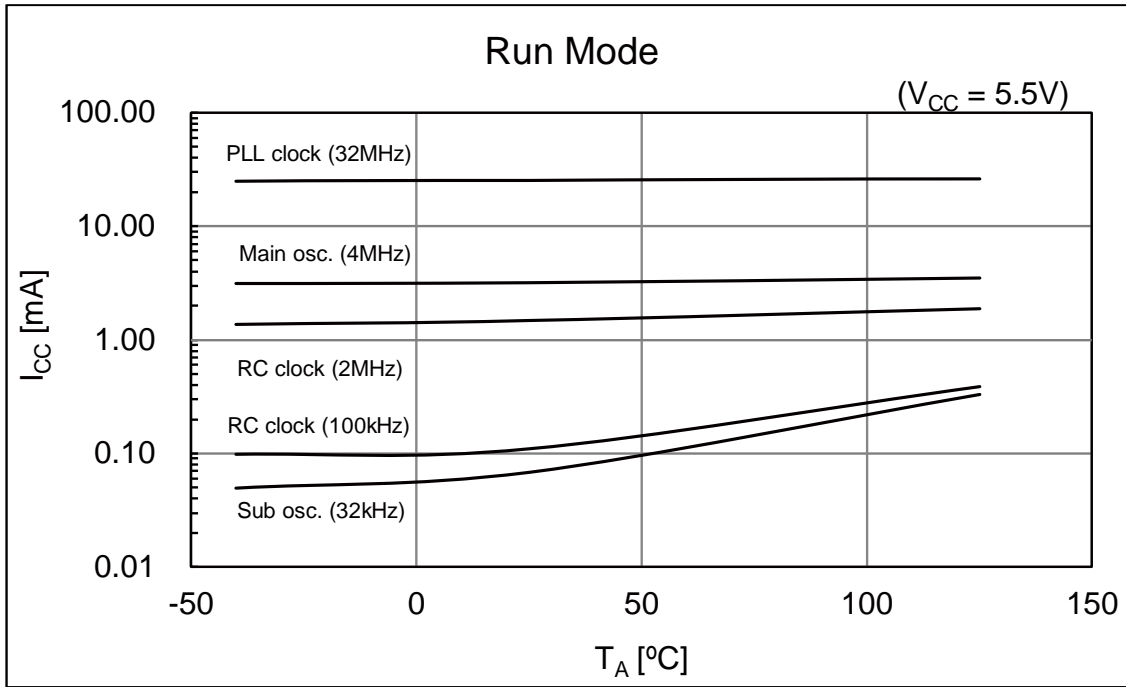

CY96F6C6

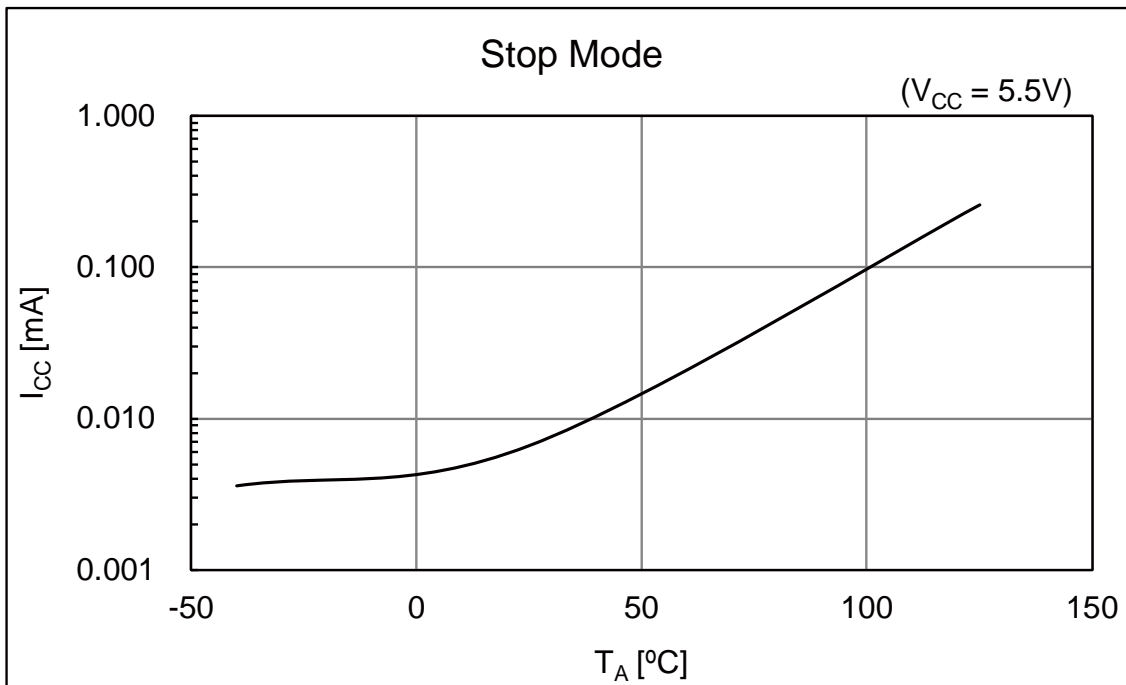
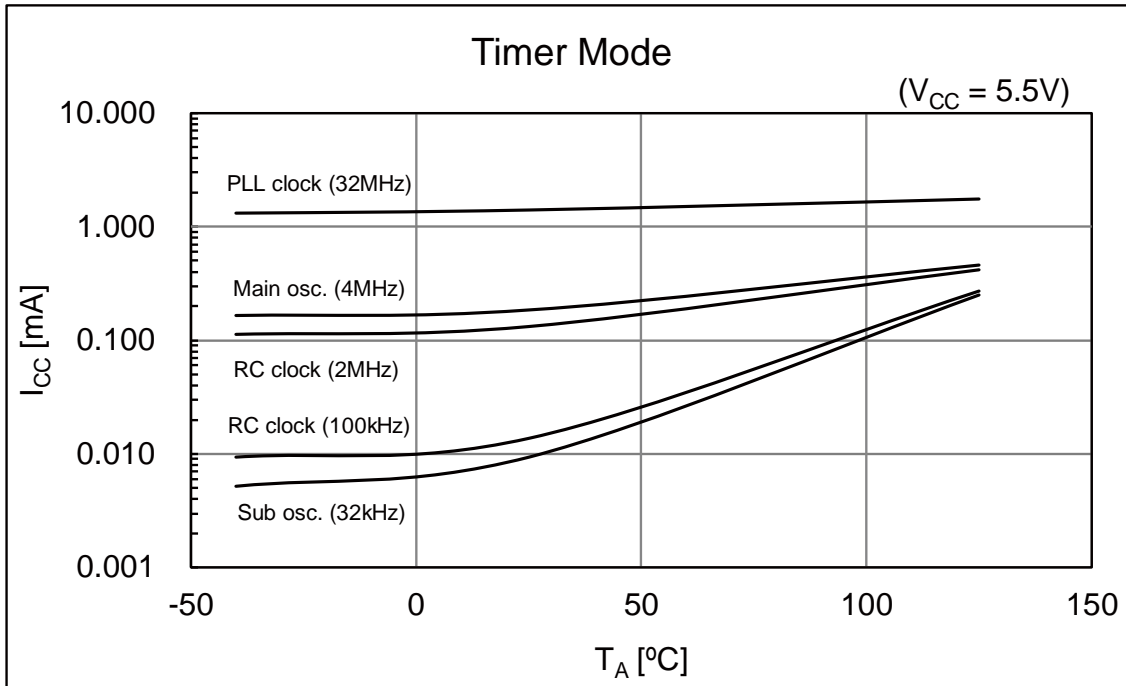

Used setting

Mode	Selected Source Clock	Clock/Regulator and FLASH Settings
Run mode	PLL	CLKS1 = CLKS2 = CLKB = CLKP1 = CLKP2 = 32MHz
	Main osc.	CLKS1 = CLKS2 = CLKB = CLKP1 = CLKP2 = 4MHz
	RC clock fast	CLKS1 = CLKS2 = CLKB = CLKP1 = CLKP2 = 2MHz
	RC clock slow	CLKS1 = CLKS2 = CLKB = CLKP1 = CLKP2 = 100kHz
	Sub osc.	CLKS1 = CLKS2 = CLKB = CLKP1 = CLKP2 = 32kHz
Sleep mode	PLL	CLKS1 = CLKS2 = CLKP1 = CLKP2 = 32MHz Regulator in High Power Mode, (CLKB is stopped in this mode)
	Main osc.	CLKS1 = CLKS2 = CLKP1 = CLKP2 = 4MHz Regulator in High Power Mode, (CLKB is stopped in this mode)
	RC clock fast	CLKS1 = CLKS2 = CLKP1 = CLKP2 = 2MHz Regulator in High Power Mode, (CLKB is stopped in this mode)
	RC clock slow	CLKS1 = CLKS2 = CLKP1 = CLKP2 = 100kHz Regulator in Low Power Mode, (CLKB is stopped in this mode)
	Sub osc.	CLKS1 = CLKS2 = CLKP1 = CLKP2 = 32kHz Regulator in Low Power Mode, (CLKB is stopped in this mode)
Timer mode	PLL	CLKMC = 4MHz, CLKPLL = 32MHz (System clocks are stopped in this mode) Regulator in High Power Mode, FLASH in Power-down / reset mode
	Main osc.	CLKMC = 4MHz (System clocks are stopped in this mode) Regulator in High Power Mode, FLASH in Power-down / reset mode
	RC clock fast	CLKMC = 2MHz (System clocks are stopped in this mode) Regulator in High Power Mode, FLASH in Power-down / reset mode
	RC clock slow	CLKMC = 100kHz (System clocks are stopped in this mode) Regulator in Low Power Mode, FLASH in Power-down / reset mode
	Sub osc.	CLKMC = 32 kHz (System clocks are stopped in this mode) Regulator in Low Power Mode, FLASH in Power-down / reset mode
Stop mode	stopped	(All clocks are stopped in this mode) Regulator in Low Power Mode, FLASH in Power-down / reset mode

## 15. Ordering Information

### MCU with CAN Controller

Part Number	Flash Memory	Package*
CY96F6C5RBPMC-GS-UJE1	Flash A (160.5KB)	120-pin plastic LQFP (LQM120)
CY96F6C6RBPMC-GS-UJE1	Flash A (288.5KB)	120-pin plastic LQFP (LQM120)

\*: For details about package, see "[Package Dimension](#)".

**16. Package Dimension**

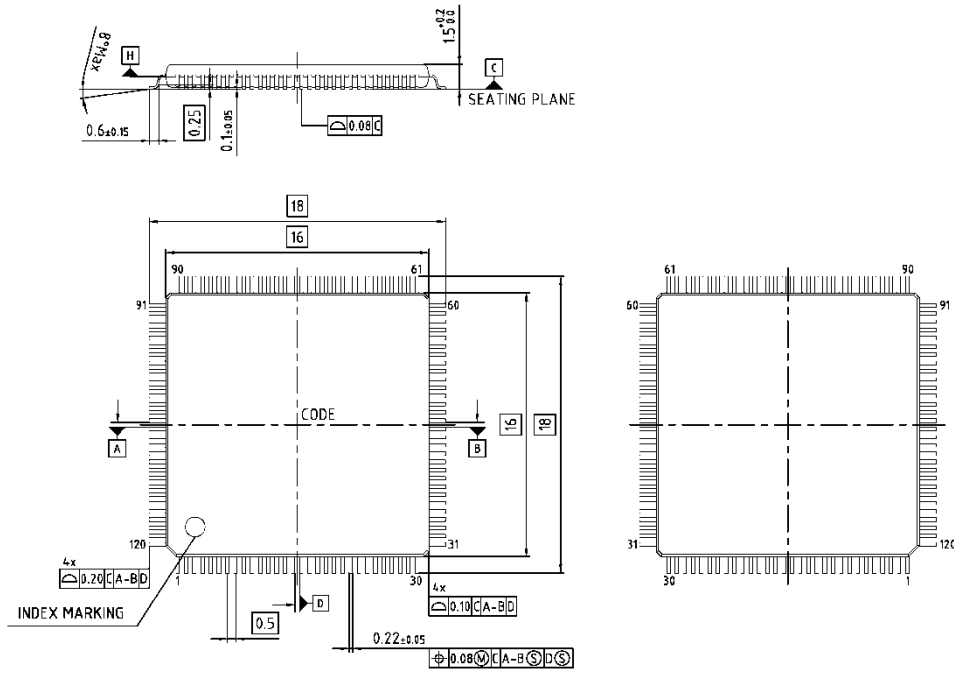

- 1) DOES NOT INCLUDE PLASTIC OR METAL PROTRUSION OF 0.25 MAX. PER SIDE
- 2) DOES NOT INCLUDE DAMBAR PROTRUSION OF 0.08 MAX. PER SIDE AT MAX. MATERIAL CONDITION

Z8B00248821 v03

## 17. Major Changes

Spancion Publication Number: MB966C0\_DS704-00014-2v1-E

Page	Section	Change Results
Revision 1.0		
-	-	Initial release
Revision 2.0		
42	Electrical Characteristics DC Characteristics Current Rating	Changed the Value of "Power supply current in Timer modes" I <sub>CCTPLL</sub> Typ: 2485µA → 1800µA (T <sub>A</sub> = +25°C) Max: 2715µA → 2250µA (T <sub>A</sub> = +25°C) Max: 4095µA → 3220µA (T <sub>A</sub> = +105°C) Max: 5055µA → 4200µA (T <sub>A</sub> = +125°C)
Revision 2.1		
-	-	Company name and layout design change
Rev. *B		
-	Marketing Part Numbers changed from an MB prefix to a CY prefix.	
5, 7, 68,69	1. Product Lineup 3. Pin Assignment 16. Ordering Information 17. Package Dimension	Package description modified to JEDEC description. FPT-120P-M21 → LQM120
68	16. Ordering Information	Revised Marketing Part Numbers as follows:  Before) <b>MCU with CAN controller</b> MB96F6C5RBPMC-GSE1 MB96F6C5RBPMC-GSE2 MB96F6C6RBPMC-GSE1 MB96F6C6RBPMC-GSE2  <b>MCU without CAN controller</b> MB96F6C5ABPMC-GSE1 MB96F6C5ABPMC-GSE2  After) <b>MCU with CAN controller</b> CY96F6C5RBPMC-GS-UJE1 CY96F6C6RBPMC-GS-UJE1

**NOTE:** Please see "Document History" about later revised information.

## Document History

Document Title: CY966C0 Series, F<sup>2</sup>MC-16FX 16-bit Microcontroller  
 Document Number: 002-04723

Revision	ECN	Orig. of Change	Submission Date	Description of Change
**	–	KSUN	01/31/2014	Migrated to Cypress and assigned document number 002-4723. No change to document contents or format.
*A	5168020	KSUN	03/29/2016	Updated to Cypress template.
*B	6003420	MIYH	12/25/2017	Updated Document Title to read as “CY966C0 Series, F <sup>2</sup> MC-16FX 16-bit Microcontroller”. Replaced MB966C0 Series with CY966C0 Series in all instances across the document. Changed the prefix of all MPNs from MB to CY in all instances across the document. Replaced FPT-120P-M21 with LQM120 in all instances across the document. Updated Ordering Information. Updated to new template. For details, please see 17. Major Changes.
*C	6601048	KSUN	06/21/2019	Updated to new template.
*D	8096587	KSUN	12/24/2024	Updated Package Dimension: Replaced 002-16172 ** (obsolete in DMS) with replacement spec Z8B00248821 v03 (active in SAP). Completing Sunset Review.

## Sales, Solutions, and Legal Information

### Worldwide Sales and Design Support

Cypress maintains a worldwide network of offices, solution centers, manufacturer's representatives, and distributors. To find the office closest to you, visit us at [Cypress Locations](#).

#### Products

Arm® Cortex® Microcontrollers	<a href="https://www.cypress.com/arm">cypress.com/arm</a>
Automotive	<a href="https://www.cypress.com/automotive">cypress.com/automotive</a>
Clocks & Buffers	<a href="https://www.cypress.com/clocks">cypress.com/clocks</a>
Interface	<a href="https://www.cypress.com/interface">cypress.com/interface</a>
Internet of Things	<a href="https://www.cypress.com/iot">cypress.com/iot</a>
Memory	<a href="https://www.cypress.com/memory">cypress.com/memory</a>
Microcontrollers	<a href="https://www.cypress.com/mcu">cypress.com/mcu</a>
PSoC	<a href="https://www.cypress.com/psoc">cypress.com/psoc</a>
Power Management ICs	<a href="https://www.cypress.com/pmic">cypress.com/pmic</a>
Touch Sensing	<a href="https://www.cypress.com/touch">cypress.com/touch</a>
USB Controllers	<a href="https://www.cypress.com/usb">cypress.com/usb</a>
Wireless Connectivity	<a href="https://www.cypress.com/wireless">cypress.com/wireless</a>

#### PSoC® Solutions

[PSoC 1](#) | [PSoC 3](#) | [PSoC 4](#) | [PSoC 5LP](#) | [PSoC 6 MCU](#)

#### Cypress Developer Community

[Community](#) | [Projects](#) | [Video](#) | [Blogs](#) | [Training](#) | [Components](#)

#### Technical Support

[cypress.com/support](https://www.cypress.com/support)

Arm and Cortex are registered trademarks of Arm Limited (or its subsidiaries) in the US and/or elsewhere.

© Cypress Semiconductor Corporation, 2011-2024. This document is the property of Cypress Semiconductor Corporation and its subsidiaries ("Cypress"). This document, including any software or firmware included or referenced in this document ("Software"), is owned by Cypress under the intellectual property laws and treaties of the United States and other countries worldwide. Cypress reserves all rights under such laws and treaties and does not, except as specifically stated in this paragraph, grant any license under its patents, copyrights, trademarks, or other intellectual property rights. If the Software is not accompanied by a license agreement and you do not otherwise have a written agreement with Cypress governing the use of the Software, then Cypress hereby grants you a personal, non-exclusive, nontransferable license (without the right to sublicense) (1) under its copyright rights in the Software (a) for Software provided in source code form, to modify and reproduce the Software solely for use with Cypress hardware products, only internally within your organization, and (b) to distribute the Software in binary code form externally to end users (either directly or indirectly through resellers and distributors), solely for use on Cypress hardware product units, and (2) under those claims of Cypress's patents that are infringed by the Software (as provided by Cypress, unmodified) to make, use, distribute, and import the Software solely for use with Cypress hardware products. Any other use, reproduction, modification, translation, or compilation of the Software is prohibited.

TO THE EXTENT PERMITTED BY APPLICABLE LAW, CYPRESS MAKES NO WARRANTY OF ANY KIND, EXPRESS OR IMPLIED, WITH REGARD TO THIS DOCUMENT OR ANY SOFTWARE OR ACCOMPANYING HARDWARE, INCLUDING, BUT NOT LIMITED TO, THE IMPLIED WARRANTIES OF MERCHANTABILITY AND FITNESS FOR A PARTICULAR PURPOSE. No computing device can be absolutely secure. Therefore, despite security measures implemented in Cypress hardware or software products, Cypress shall have no liability arising out of any security breach, such as unauthorized access to or use of a Cypress product. CYPRESS DOES NOT REPRESENT, WARRANT, OR GUARANTEE THAT CYPRESS PRODUCTS, OR SYSTEMS CREATED USING CYPRESS PRODUCTS, WILL BE FREE FROM CORRUPTION, ATTACK, VIRUSES, INTERFERENCE, HACKING, DATA LOSS OR THEFT, OR OTHER SECURITY INTRUSION (collectively, "Security Breach"). Cypress disclaims any liability relating to any Security Breach, and you shall and hereby do release Cypress from any claim, damage, or other liability arising from any Security Breach. In addition, the products described in these materials may contain design defects or errors known as errata which may cause the product to deviate from published specifications. To the extent permitted by applicable law, Cypress reserves the right to make changes to this document without further notice. Cypress does not assume any liability arising out of the application or use of any product or circuit described in this document. Any information provided in this document, including any sample design information or programming code, is provided only for reference purposes. It is the responsibility of the user of this document to properly design, program, and test the functionality and safety of any application made of this information and any resulting product. "High-Risk Device" means any device or system whose failure could cause personal injury, death, or property damage. Examples of High-Risk Devices are weapons, nuclear installations, surgical implants, and other medical devices. "Critical Component" means any component of a High-Risk Device whose failure to perform can be reasonably expected to cause, directly or indirectly, the failure of the High-Risk Device, or to affect its safety or effectiveness. Cypress is not liable, in whole or in part, and you shall and hereby do release Cypress from any claim, damage, or other liability arising from any use of a Cypress product as a Critical Component in a High-Risk Device. You shall indemnify and hold Cypress, its directors, officers, employees, agents, affiliates, distributors, and assigns harmless from and against all claims, costs, damages, and expenses, arising out of any claim, including claims for product liability, personal injury or death, or property damage arising from any use of a Cypress product as a Critical Component in a High-Risk Device. Cypress products are not intended or authorized for use as a Critical Component in any High-Risk Device except to the limited extent that (i) Cypress's published data sheet for the product explicitly states Cypress has qualified the product for use in a specific High-Risk Device, or (ii) Cypress has given you advance written authorization to use the product as a Critical Component in the specific High-Risk Device and you have signed a separate indemnification agreement.

Cypress, the Cypress logo, Spansion, the Spansion logo, and combinations thereof, WICED, PSoC, CapSense, EZ-USB, F-RAM, and Traveo are trademarks or registered trademarks of Cypress in the United States and other countries. For a more complete list of Cypress trademarks, visit [cypress.com](https://www.cypress.com). Other names and brands may be claimed as property of their respective owners.